

# OPERATION AND SERVICE MANUAL

## MODEL MDC-360 MAXTEK FILM DEPOSITION CONTROLLER

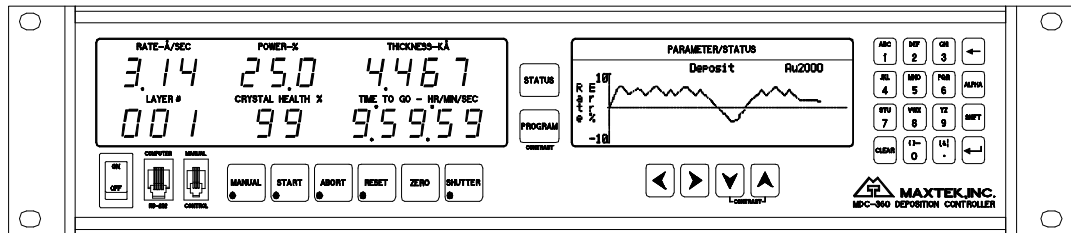

P/N 179800

S/N \_\_\_\_\_



<http://www.maxtekinc.com>

11980 Telegraph Road, Suite 104, Santa Fe Springs, CA 90670-6084

Tel: (562) 906-1515 • Fax: (562) 906-1622

Email: [sales@maxtekinc.com](mailto:sales@maxtekinc.com) • [support@maxtekinc.com](mailto:support@maxtekinc.com)

© 1995-2002 MAXTEK, INC. All rights reserved.

First Edition, March 1995

Second Edition, Revision A, March 1996

Revision B, June 1996

Revision C, December 1996

Revision D, February 1997

Revision E, January 1998

Revision F, March 1998

Revision G, May 1998

Revision H, January 1999

Revision I, November 1999

Revision J, February 2000

Revision K, August 2000

## WARRANTY

Maxtek, Inc. warrants the product to be free of functional defects in material and workmanship and that it will perform in accordance with its published specification for a period of (twenty-four) 24 months.

The foregoing warranty is subject to the condition that the product be properly operated in accordance with instructions provided by Maxtek, Inc. or has not been subjected to improper installation or abuse, misuse, negligence, accident, corrosion, or damage during shipment.

Purchaser's sole and exclusive remedy under the above warranty is limited to, at Maxtek's option, repair or replacement of defective equipment or return to purchaser of the original purchase price. Transportation charges must be prepaid and upon examination by Maxtek the equipment must be found not to comply with the above warranty. In the event that Maxtek elects to refund the purchase price, the equipment shall be the property of Maxtek.

This warranty is in lieu of all other warranties, expressed or implied and constitutes fulfillment of all of Maxtek's liabilities to the purchaser. Maxtek does not warrant that the product can be used for any particular purpose other than that covered by the applicable specifications. Maxtek assumes no liability in any event, for consequential damages, for anticipated or lost profits, incidental damage of loss of time or other losses incurred by the purchaser or third party in connection with products covered by this warranty or otherwise.

## DISCLOSURE

The disclosure of this information is to assist owners of Maxtek equipment to properly operate and maintain their equipment, and does not constitute the release of rights thereof. Reproduction of this information and equipment described herein is prohibited without prior written consent from Maxtek, Inc., 11980 Telegraph Road, Suite 104, Santa Fe Springs, California, 90670.

## SAFETY

**All standard safety procedures associated with the safe handling of electrical equipment must be observed. Always disconnect power when working inside the controller. Only properly trained personnel should attempt to service the instrument.**

# Table of Contents

<b>1.</b>	<b>GENERAL DESCRIPTION .....</b>	<b>1-1</b>
1.1	PURPOSE .....	1-1
1.2	FEATURES.....	1-1
1.2.1	EXTENSIVE PROGRAM STORAGE.....	1-1
1.2.2	DYNAMIC MEASUREMENT UPDATE RATE.....	1-1
1.2.3	SUPERIOR GRAPHICS DISPLAY.....	1-1
1.2.4	PROGRAM SECURITY.....	1-1
1.2.5	DESIGNED FOR UNATTENDED OPERATION.....	1-1
1.2.6	FAIL SAFE ABORTS.....	1-1
1.2.7	ABORT STATUS RETENTION .....	1-2
1.2.8	RUN COMPLETION ON CRYSTAL FAILURE .....	1-2
1.2.9	POWERFUL SYSTEM INTERFACE.....	1-2
1.2.10	POWER SUPPLY NOISE TOLERANCE.....	1-2
1.2.11	INTERNATIONAL STANDARD POWER CONNECTOR .....	1-2
1.2.12	FIELD UPGRADABLE.....	1-2
1.3	SPECIFICATIONS.....	1-3
1.3.1	MEASUREMENT.....	1-3
1.3.2	DISPLAY.....	1-3
1.3.3	COMMUNICATION.....	1-3
1.3.4	PROGRAM STORAGE CAPACITY.....	1-3
1.3.5	PROCESS PARAMETERS.....	1-3
1.3.6	MATERIAL PARAMETERS.....	1-3
1.3.7	INPUT/OUTPUT CAPABILITY.....	1-5
1.3.8	SENSOR PARAMETERS.....	1-5
1.3.9	SOURCE PARAMETERS .....	1-5
1.3.10	RECORDER PARAMETERS.....	1-6
1.3.11	UTILITY SETUP PARAMETER .....	1-6
1.3.12	OTHER.....	1-6
1.4	ACCESSORIES.....	1-6
<b>2.</b>	<b>FRONT PANEL DISPLAYS AND CONTROLS .....</b>	<b>2-1</b>
2.1	OPERATING DISPLAYS .....	2-1
2.1.1	RATE.....	2-1
2.1.2	POWER .....	2-1
2.1.3	THICKNESS .....	2-1
2.1.4	LAYER NUMBER.....	2-1
2.1.5	CRYSTAL HEALTH %.....	2-1
2.1.6	TIME TO GO.....	2-2
2.2	PARAMETER/STATUS DISPLAYS .....	2-2
2.3	OPERATING CONTROLS .....	2-2
2.3.1	MANUAL KEY.....	2-2
2.3.2	START KEY.....	2-3
2.3.3	ABORT KEY.....	2-3
2.3.4	RESET KEY .....	2-3
2.3.5	ZERO KEY.....	2-3
2.3.6	SHUTTER KEY.....	2-3
2.3.7	STATUS KEY .....	2-3
2.3.8	ARROW KEYS.....	2-4
2.3.9	PROGRAM KEY.....	2-4
2.3.10	ALPHANUMERIC KEYBOARD.....	2-5
<b>3.</b>	<b>BENCH CHECKOUT &amp; INSPECTION .....</b>	<b>3-1</b>
3.1	INSPECTION.....	3-1
3.2	INITIAL POWER UP.....	3-1

3.3	SAMPLE PROGRAM.....	3-1
3.3.1	MATERIAL #1 PARAMETERS.....	3-2
3.3.2	MATERIAL #2 PARAMETERS.....	3-3
3.3.3	PROCESS PARAMETERS.....	3-4
3.4	SIMULATE OPERATION.....	3-4
3.5	MANUAL OPERATION.....	3-4
3.6	INSTALLING OPTION BOARDS.....	3-4
3.6.1	SOURCE-SENSOR BOARD.....	3-5
3.6.2	DISCRETE I/O BOARD.....	3-5
3.6.3	IEEE-488 OPTION BOARD.....	3-5
3.7	DIGITAL TO ANALOG CONVERTER (DAC) CHECKOUT.....	3-5
<b>4.</b>	<b>PROGRAMMING AND CONTROLLER SETUP.....</b>	<b>4-1</b>
4.1	GENERAL.....	4-1
4.1.1	NAVIGATING THE MENU STRUCTURE.....	4-1
4.1.2	ENTERING ALPHA CHARACTERS.....	4-2
4.1.3	ENTERING TIME PARAMETERS.....	4-2
4.1.4	COPYING AND DELETING.....	4-2
4.1.5	PASSWORD PROTECTION.....	4-2
4.1.5.1	VIEW/RUN PROCESS PASSWORD.....	4-3
4.1.5.2	EDIT PROCESS PASSWORD.....	4-3
4.1.5.3	EDIT MATERIAL PASSWORD.....	4-3
4.1.6	ADJUSTING PARAMETER/STATUS DISPLAY CONTRAST.....	4-3
4.2	GETTING STARTED.....	4-4
4.2.1	UTILITY SETUP.....	4-4
4.2.2	DAC SETUP.....	4-4
4.2.3	SOURCE SETUP.....	4-4
4.2.4	SENSOR SETUP.....	4-7
4.2.4.1	EXAMPLE USING MAXTEK'S RSH-600 SIX CRYSTAL SENSOR HEAD.....	4-9
4.2.5	INPUT, OUTPUT AND ACTION SETUP.....	4-9
4.2.6	DISPLAY SETUP.....	4-10
4.2.7	MATERIAL SETUP.....	4-10
4.2.7.1	POWER RAMPS.....	4-11
4.2.7.2	AUTOMATIC CRYSTAL SWITCHING.....	4-12
4.2.7.3	RATE ESTABLISH.....	4-12
4.2.7.4	RATE RAMPS.....	4-12
4.2.7.5	RATE SAMPLE MODE.....	4-12
4.2.7.6	RATE DEVIATION ALARM.....	4-12
4.2.8	PROCESS SETUP.....	4-13
4.2.9	STARTING A NEW PROCESS.....	4-13
4.2.10	RESUMING A PROCESS FROM ABORT OR HALT.....	4-13
4.3	DETAILED PROGRAMMING.....	4-13
4.3.1	VIEW/EDIT PROCESS.....	4-13
4.3.1.1	DEFINE A PROCESS.....	4-14
4.3.2	VIEW/EDIT MATERIAL.....	4-16
4.3.2.1	DEFINE A MATERIAL.....	4-16
4.3.3	SYSTEM SETUP.....	4-23
4.3.3.1	EDIT DISPLAY SETUP.....	4-23
4.3.3.2	PROGRAM INPUTS.....	4-24
4.3.3.3	PROGRAM OUTPUTS.....	4-26
4.3.3.4	PROGRAM ACTIONS.....	4-31
4.3.3.5	EDIT SENSOR SETUP.....	4-33
4.3.3.6	EDIT SOURCE SETUP.....	4-36
4.3.3.7	EDIT DAC SETUP.....	4-39
4.3.3.8	EDIT UTILITY SETUP.....	4-39
<b>5.</b>	<b>OPERATING THE MDC-360.....</b>	<b>5-1</b>
5.1	SIGN-ON SCREEN.....	5-1
5.2	STARTING A NEW PROCESS.....	5-1
5.3	STARTING A NEW LAYER.....	5-2

5.4	RESUMING AN ABORTED OR HALTED PROCESS .....	5-2
5.5	STATUS DISPLAYS .....	5-3
5.6	VIEWING RESULTS .....	5-4
5.7	MODES.....	5-7
5.7.1	PROCESS READY.....	5-7
5.7.2	ABORT .....	5-7
5.7.3	HALT (SOFT ABORT).....	5-7
5.7.4	IN PROCESS.....	5-7
5.7.5	NOT SAMPLING.....	5-7
5.7.6	PROCESS COMPLETE.....	5-7
5.7.7	MANUAL.....	5-8
5.7.8	SIMULATE .....	5-8
5.8	STATES .....	5-8
5.9	TROUBLE, ERROR AND WARNING MESSAGES.....	5-8
5.9.1	DESCRIPTION .....	5-9
5.9.1.1	MIN RATE&MAX POWER .....	5-9
5.9.1.2	MAX RATE&MIN POWER .....	5-9
5.9.1.3	SYSTEM SETUP MEMORY CORRUPTED.....	5-9
5.9.1.4	PROCESS MEMORY CORRUPTED.....	5-9
5.9.1.5	MATERIAL MEMORY CORRUPTED.....	5-10
5.9.1.6	RATE EST. ERROR .....	5-10
5.9.1.7	CRYSTAL FAILURE .....	5-10
5.9.1.8	SOURCE FAULT .....	5-10
5.9.1.9	SENSOR FAULT.....	5-10
5.9.1.10	TIME POWER.....	5-10
5.9.1.11	RATE DEV. ALARM .....	5-10
5.9.1.12	ALARM ACTION .....	5-10
5.9.1.13	CRYSTAL MARGINAL.....	5-10
5.9.1.14	RATE DEV. ALERT.....	5-11
5.9.1.15	MAX POWER ALERT .....	5-11
5.9.1.16	MIN POWER ALERT.....	5-11
5.9.1.17	ALERT ACTION.....	5-11
5.9.1.18	XTAL FAIL SWITCH .....	5-11
5.9.1.19	XTAL MRGN SWITCH.....	5-11
5.9.1.20	RATE DEV. ATTN .....	5-11
5.9.1.21	MAXIMUM POWER.....	5-11
5.9.1.22	MINIMUM POWER.....	5-11
5.9.1.23	CHANGE POCKET.....	5-11
5.9.1.24	CHANGE CRYSTAL.....	5-12
5.9.1.25	ATTENTION ACTION.....	5-12
<b>6.</b>	<b>TUNING THE MDC-360 CONTROL LOOP.....</b>	<b>6-1</b>
6.1	CONTROL LOOP BASICS .....	6-1
6.2	CONTROL LOOPS APPLIED TO VACUUM DEPOSITION.....	6-2
6.3	ESTABLISHING MDC-360 CONTROL LOOP PARAMETERS .....	6-3
<b>7.</b>	<b>INPUT/OUTPUT CHARACTERISTICS.....</b>	<b>7-1</b>
7.1	SOURCE CONTROL VOLTAGE OUTPUT .....	7-1
7.2	SENSOR INPUT .....	7-1
7.3	DISCRETE OUTPUTS.....	7-1
7.4	DISCRETE INPUTS.....	7-1
7.5	DIGITAL-TO-ANALOG CONVERTER OUTPUTS .....	7-2
7.6	DIGITAL-TO-ANALOG CONVERTER CONTROL INPUTS .....	7-2
<b>8.</b>	<b>CONTROLLER INSTALLATION .....</b>	<b>8-1</b>
8.1	MOUNTING .....	8-1
8.2	PROPER GROUNDING.....	8-1
8.3	EXTERNAL CONNECTIONS .....	8-1
8.3.1	POWER .....	8-1

8.3.2	VOLTAGE SELECTION .....	8-1
8.3.3	GROUND LUG .....	8-2
8.3.4	REMOTE POWER HANDSET .....	8-2
8.3.5	SOURCE-SENSOR .....	8-2
8.3.6	RS-232 COMMUNICATION .....	8-2
8.3.7	DISCRETE INPUT/OUTPUT .....	8-3
8.3.8	DIGITAL-TO-ANALOG CONVERTER (DAC) .....	8-3
<b>9.</b>	<b>SYSTEM INSTALLATION .....</b>	<b>9-1</b>
9.1	SENSOR HEAD DESCRIPTION .....	9-1
9.2	SENSOR HEAD INSTALLATION .....	9-1
9.3	SENSOR OSCILLATOR .....	9-2
9.3.1	INSTALLATION .....	9-2
9.4	INSTRUMENTATION FEEDTHROUGH .....	9-2
9.5	SENSOR CRYSTAL REPLACEMENT .....	9-2
9.6	TYPICAL SYSTEM INSTALLATION .....	9-3
<b>10.</b>	<b>THEORY OF OPERATION .....</b>	<b>10-1</b>
10.1	BASIC MEASUREMENT .....	10-1
10.2	FILM THICKNESS CALCULATION .....	10-1
10.3	CRYSTAL HEALTH CALCULATION .....	10-3
10.4	RATE CALCULATION .....	10-4
10.5	RATE CONTROL .....	10-4
10.6	EMPIRICAL CALIBRATION .....	10-4
10.6.1	FILM DENSITY .....	10-4
10.6.2	TOOLING FACTOR .....	10-5
10.6.3	ACOUSTIC IMPEDANCE .....	10-5
<b>11.</b>	<b>COMPUTER INTERFACE .....</b>	<b>11-1</b>
11.1	GENERAL .....	11-1
11.2	RS-232 SERIAL INTERFACE .....	11-1
11.3	RS-485 SERIAL INTERFACE .....	11-1
11.4	IEEE-488 PARALLEL INTERFACE .....	11-2
11.5	PROTOCOL .....	11-2
11.6	DATA TYPES .....	11-3
11.7	MESSAGE RECEIVED STATUS .....	11-3
11.8	INSTRUCTION SUMMARY .....	11-4
11.9	INSTRUCTION DESCRIPTIONS .....	11-5
<b>12.</b>	<b>REPAIR AND MAINTENANCE .....</b>	<b>12-1</b>
12.1	HANDLING PRECAUTIONS .....	12-1
12.2	MAINTENANCE PHILOSOPHY .....	12-1
12.3	TROUBLE SHOOTING AIDS .....	12-2
12.4	RETURNING THE MDC-360 TO THE FACTORY .....	12-3
<b>13.</b>	<b>APPENDIX A .....</b>	<b>13-1</b>
<b>14.</b>	<b>APPENDIX B – PARAMETER TEMPLATES .....</b>	<b>14-2</b>
14.1	MATERIAL .....	14-3
14.2	PROCESS .....	14-5
14.3	DISPLAY SETUP .....	14-6
14.4	INPUTS .....	14-7
14.5	OUTPUTS .....	14-8
14.6	ACTIONS .....	14-9
14.7	SENSOR SETUP .....	14-10
14.8	SOURCE SETUP .....	14-10
14.9	DAC SETUP .....	14-11

14.10 UTILITY SETUP .....14-11

## Table of Figures

FIGURE 2-1 OPERATING DISPLAY .....	2-1
FIGURE 2-2 PARAMETER/STATUS DISPLAY .....	2-2
FIGURE 2-3 PROGRAMMING SECTION .....	2-3
FIGURE 2-4 ARROW KEYS .....	2-4
FIGURE 2-5 ALPHANUMERIC KEYBOARD .....	2-5
FIGURE 3-1 REMOTE POWER HANDSET .....	3-7
FIGURE 4-1 THE MAIN MENU .....	4-1
FIGURE 4-2 SELECT PROCESS SCREEN.....	4-14
FIGURE 4-3 DEFINE PROCESS SCREEN.....	4-14
FIGURE 4-4 SELECT LAYER MATERIAL SCREEN.....	4-16
FIGURE 4-5 SELECT MATERIAL SCREEN .....	4-16
FIGURE 4-6 DEFINE MATERIAL SCREEN.....	4-17
FIGURE 4-7 SYSTEM SETUP MENU SCREEN .....	4-23
FIGURE 4-8 DISPLAY SETUP SCREEN .....	4-23
FIGURE 4-9 SELECT OUTPUT SCREEN .....	4-27
FIGURE 4-10 PROGRAM OUTPUT SCREEN .....	4-27
FIGURE 4-11 SENSOR SETUP SCREEN.....	4-33
FIGURE 4-12 SOURCE SETUP SCREEN .....	4-36
FIGURE 4-13 DAC SETUP SCREEN .....	4-39
FIGURE 4-14 UTILITY SETUP SCREEN .....	4-39
FIGURE 5-1 SIGN-ON SCREEN .....	5-1
FIGURE 5-2 RUN PROCESS SELECTION SCREEN.....	5-2
FIGURE 5-3 RATE VS. TIME GRAPH.....	5-3
FIGURE 5-4 RATE DEVIATION VS. TIME GRAPH.....	5-3
FIGURE 5-5 THICKNESS VS. TIME GRAPH.....	5-3
FIGURE 5-6 POWER VS. TIME GRAPH .....	5-4
FIGURE 5-7 SOURCE/SENSOR STATUS SCREEN.....	5-4
FIGURE 5-8 I/O STATUS SCREEN .....	5-4
FIGURE 5-9 VIEW RESULTS SCREEN.....	5-6
FIGURE 5-10 RATE VS. TIME PROCESS LOG GRAPH.....	5-6
FIGURE 5-11 TYPICAL PROCESS PROFILE.....	5-13
FIGURE 7-1 PASSIVE INPUT BUFFER CIRCUIT .....	7-3
FIGURE 7-2 ACTIVE INPUT BUFFER CIRCUIT .....	7-4
FIGURE 7-3 DAC OUTPUT CIRCUIT .....	7-5
FIGURE 7-4 SENSOR INPUT BUFFER CIRCUIT .....	7-6
FIGURE 7-5 SOURCE OUTPUT DRIVER CIRCUIT .....	7-7
FIGURE 8-1 MDC-360 FRONT PANEL .....	8-4
FIGURE 8-2 MDC-360 REAR PANEL .....	8-5
FIGURE 8-3 DAC SOCKET CONNECTOR PIN OUT.....	8-6
FIGURE 8-4 SOURCE SOCKET CONNECTOR PIN OUT.....	8-6
FIGURE 8-5 D9S DTE REAR-PANEL RS-232 SOCKET CONNECTOR .....	8-7
FIGURE 8-6 D37P DISCRETE I/O PLUG CONNECTOR.....	8-8
FIGURE 8-7 RJ11 FRONT PANEL RS-232 CONNECTOR .....	8-9
FIGURE 8-8 FRONT PANEL MANUAL POWER CONNECTOR.....	8-9
FIGURE 8-9 MDC-360 TOP VIEW (COVER REMOVED).....	8-10
FIGURE 9-1 SENSOR OSCILLATOR SCHEMATIC .....	9-4
FIGURE 9-2 SENSOR OSCILLATOR OUTLINE.....	9-5
FIGURE 9-3 IF-111 INSTRUMENTATION FEEDTHROUGH OUTLINE.....	9-6
FIGURE 9-4 SH-102 SENSOR HEAD OUTLINE .....	9-7
FIGURE 9-5 TYPICAL SYSTEM INSTALLATION.....	9-8
FIGURE 13-1 PLUG PIN OUT - SOURCE CABLE CONNECTOR.....	13-1
FIGURE 13-2 PLUG PIN OUT - DAC CABLE CONNECTOR .....	13-2
FIGURE 15-1 MENU MAP .....	15-1

## List of Tables

TABLE 5-1 TROUBLE CONDITIONS AND WARNINGS .....	5-9
TABLE 8-1 DAC SYSTEM INTERFACE CONNECTOR PIN ASSIGNMENTS .....	8-6
TABLE 8-2 SOURCE CONTROL SYSTEM INTERFACE CONNECTOR PIN ASSIGNMENTS.....	8-6
TABLE 8-3 D9 REAR PANEL RS-232/RS-485 CONNECTOR PIN ASSIGNMENTS.....	8-7
TABLE 8-4 DISCRETE I/O SYSTEM INTERFACE CONNECTOR PIN ASSIGNMENTS ....	8-8
TABLE 8-5 RJ11 FRONT PANEL RS-232 CONNECTOR PIN ASSIGNMENTS .....	8-9
TABLE 8-6 FRONT PANEL MANUAL POWER CONNECTOR PIN ASSIGNMENTS .....	8-9
TABLE 10-1 MATERIAL DENSITY AND ACOUSTIC IMPEDANCE VALUE.....	10-6
TABLE 13-1 SOURCE CONTROL CABLE COLOR CODE - (4 PIN MINI DIN).....	13-1
TABLE 13-2 DAC CABLE COLOR CODE - (7 PIN MINI DIN).....	13-2

## **1. GENERAL DESCRIPTION**

### **1.1 PURPOSE**

The MDC-360 provides both automatic control of single or multi-layer film deposition in either a production or development environment and improved predictability and repeatability of deposited film characteristics through dependable digital control of the deposition process. It runs unattended in the fully automatic mode and provides such features as run completion in the event of crystal failure, and extensive internal checking. Performance limits and the abort feature can be set by the user.

### **1.2 FEATURES**

The MDC-360 incorporates numerous features which are economically justifiable as a result of rapid advances in semiconductor technology and the advent of low cost microprocessors.

#### **1.2.1 EXTENSIVE PROGRAM STORAGE**

The MDC-360 is capable of storing up to 99 processes, 999 layer definitions and 32 complete material definitions. Once a program is entered it will be maintained in memory for a minimum of 5 years without external power.

#### **1.2.2 DYNAMIC MEASUREMENT UPDATE RATE**

Measurement is dynamically adjusted from 0.5 to 10 Hz for optimum resolution and control.

#### **1.2.3 SUPERIOR GRAPHICS DISPLAY**

The MDC-360 features a 256x64 pixel LCD graphics display allowing real time graphing of important process information such as rate, rate deviation, thickness and power.

#### **1.2.4 PROGRAM SECURITY**

To assure the integrity of stored programs, the MDC-360 incorporates edit passwords to guard against unauthorized program changes.

#### **1.2.5 DESIGNED FOR UNATTENDED OPERATION**

The MDC-360 has been designed for truly automatic operation and toward this end incorporates extensive internal monitoring and overriding abort circuitry to minimize the possibility of damage in the event of a failure or other problem in the total deposition system. In addition there are attention, alert and alarm signals with adjustable volume for trouble and routine operator call.

#### **1.2.6 FAIL SAFE ABORTS**

In the event of an MDC-360 failure, as evidenced by unsatisfactory internal checks, the MDC-360 will abort the process and shut off all outputs. In addition to the internal checks, the MDC-360 also provides user enabled aborts on excessive rate control error or crystal failure.

### **1.2.7 ABORT STATUS RETENTION**

In the event that the MDC-360 does abort during the deposition process, pertinent information is stored at the time of abort. The process can be resumed after the problem is corrected.

### **1.2.8 RUN COMPLETION ON CRYSTAL FAILURE**

The extensive monitoring and abort functions are designed to protect the system and/or process from serious and hopefully infrequent malfunctions of the deposition system. A condition which need not cause an abort is the condition of crystal failure. The MDC-360 can be set to abort upon crystal failure, or run to completion using a backup crystal or time/power method.

### **1.2.9 POWERFUL SYSTEM INTERFACE**

Fully programmable discrete inputs and outputs permit the MDC-360 to be easily interfaced into deposition systems controlling the most complex processes. Also, source control outputs are fully isolated avoiding ground loop problems. The MDC-360 also supports input from an optical monitor for optical termination of film thickness.

### **1.2.10 POWER SUPPLY NOISE TOLERANCE**

Integral RFI filter and large energy storage capacitors will tolerate high levels of power supply noise and power interruptions of 700 ms or less without effect.

### **1.2.11 INTERNATIONAL STANDARD POWER CONNECTOR**

The power connector is internationally approved and meets IEC (International Electrotechnical Commission) standards. It allows selection of input power voltages ranging from 100 to 240 volts at a frequency of 50 or 60 Hz and includes an integral RFI filter.

### **1.2.12 FIELD UPGRADABLE**

Plug-in interface boards and option boards allow the basic unit to be upgraded in the field to the maximum system level.

# MDC-360 DEPOSITION CONTROLLER

## 1.3 SPECIFICATIONS

### 1.3.1 MEASUREMENT

Frequency Resolution	0.03 Hz @6.0 MHz
Mass Resolution	0.375 ng/cm <sup>2</sup>
Thickness Accuracy	0.5% + 1 count
Measurement Update Rate	Dynamically adjusted, 0.5 to 10 Hz
Display Update Rate	10 Hz
Sensor Crystal Frequency	2.5, 3, 5, 6, 9, 10 MHz

### 1.3.2 DISPLAY

Thickness Display	Autoranging: 0.000 to 999.9 KÅ
Rate Display	Autoranging: 0.0 to 999 Å/sec
Power Display	0.0 to 99.9%
Time To Go	0 to 9:59:59 H:MM:SS
Crystal Health %	0 to 99%
Layer Number	1 to 999
Graphics Display	256X64 LCD with CCFL backlighting

### 1.3.3 COMMUNICATION

	RS-232 serial port standard
	RS-485 serial port optional
	IEEE-488 bus interface optional

### 1.3.4 PROGRAM STORAGE CAPACITY

Process	99, user definable
Layer	999, user definable
Material	32, user definable

### 1.3.5 PROCESS PARAMETERS

Process Name	12 character string
Edit password	4 character string
Run/View password	4 character string
Layer# 1 to 999	Material name, Thickness

### 1.3.6 MATERIAL PARAMETERS

Material Name	10 character string
---------------	---------------------

## MDC-360 DEPOSITION CONTROLLER

---

Sensor #	1 to 4
Crystal #	1 to 8
Source #	1 to 4
Pocket #	1 to 8
Material Density	0.80 to 99.9 gm/cm <sup>3</sup>
Acoustic Impedance	0.50 to 59.9 gm/cm <sup>2</sup> sec
Tooling Factor	10.0 to 499.9%
Proportional gain	0.00 to 9999
Integral Time constant	0 to 99.9 sec
Derivative Time constant	0 to 99.9 sec
Rise to Soak Time	0 to 9:59:59 H:MM:SS
Soak Power	0 to 99%
Soak Time	0 to 9:59:59
Rise to Predeposit Time	0 to 9:59:59
Predeposit Power	0 to 99.9%
Predeposit Time	0 to 9:59:59
Rate Establish Time	0 to 60 sec
Rate Establish Error	0 to 99.9%
Deposition Rate (1 to 5)	00.0 to 999.9 Å/sec
Rate Ramp Start (1 to 4)	0.000 to 999.9 KÅ
Rate Ramp Stop (1 to 4)	0.000 to 999.9 KÅ
Time Setpoint	0 to 9:59:59
Ramp to Feed Time	0 to 9:59:59
Feed Power	0 to 99.9%
Feed Time	0 to 9:59:59
Ramp to Idle Time	0 to 9:59:59
Idle Power	0 to 99.9%
Maximum Power	0 to 99.9%
Power Alarm Delay	0 to 99 sec
Minimum Power	0 to 99.9%
Rate Deviation Attention	0 to 99.9%
Rate Deviation Alarm	0 to 99.9%
Rate Deviation Abort	0 to 99.9%
Sample Dwell %	0 to 100.0%
Sample Period	0 to 9:59:59
Crystal Fail	Switch, Time Power, or Halt
Backup Sensor #	1 to 4
Backup Crystal #	1 to 8
Backup Tooling Factor	0 to 499.9%
Material Password	4 character string

The MDC-360 also has a built in material library that contains many common material names along with their density and acoustic impedance values.

## MDC-360 DEPOSITION CONTROLLER

### 1.3.7 INPUT/OUTPUT CAPABILITY

Sensor Inputs	2 Standard and 2 optional BNC inputs
Source Outputs	2 Standard and 2 optional fully isolated, 2.5, 5, 10 volts @ 20 ma. 0.002% resolution
Discrete Inputs	8 Standard and 8 optional fully programmable inputs. The Passive I/O card (PN#179216) has TTL level inputs activated by a short across the input pins. The Active I/O card (PN#179239) has inputs activated by 12 to 120 volt AC/DC across the input pins.
Discrete Outputs	8 standard and 8 optional fully programmable, SPST relay, 120VA, 2A max.
Abort Output	1 standard and 1 optional SPST Relay, 120VA, 2A max.
Remote Power Handset	Front panel, RJH jack
RS-232 Communication	Rear panel, 9 pin, Full duplex, DTE Front panel, RJ11 jack, Full duplex
DAC Recorder Outputs	Two 0 to 5 volts, 0.02% resolution

### 1.3.8 SENSOR PARAMETERS

Number of Crystals	1 to 8
Shutter Relay Type	Normally open, normally closed, dual, or none.
Position Control	Manual, direct, BCD, or individual.
Position Drive	Up, down, Fast, inline, single step, or double step.
Feedback Type	Individual, BCD, single home, in position, or no feedback.
Rotator Delay	0 to 99 sec

### 1.3.9 SOURCE PARAMETERS

Number of Pockets	1 to 8
Shutter Relay Type	Normally open, normally closed, or none.
Shutter Delay	0.0 to 9.9 sec
Position Control	Manual, direct, BCD, or individual.
Position Drive	Up, down, Fast, inline, single step, or double step.
Feedback Type	Individual, BCD, single home, in position, or no feedback.

## MDC-360 DEPOSITION CONTROLLER

---

Rotator Delay	0 to 99 sec
Source Voltage Range	2.5, 5, 10 volts

### 1.3.10 RECORDER PARAMETERS

Recorder #1/#2 Output	Rate, rate dev., power or thickness
Recorder #1/#2 Scale	Full scale %, 2/3 digit

### 1.3.11 UTILITY SETUP PARAMETER

Crystal Frequency	2.5, 3, 5, 6, 9, 10 MHz
Simulate Mode	On/Off
Interface Address	1 to 32
Attention Volume	0 to 10
Alert Volume	0 to 10
Alarm Volume	0 to 10
Data Points/Minute	30,60,120,300,600 PPM
Time	0 to 23:59
Date	MM/DD/YY

### 1.3.12 OTHER

Input Power Requirements	100, 120, 200, 240 VAC; 50/60 Hz; 25 watts
Operating Temperature Range	0 to 50°C
Physical Weight	10 LB
Physical Size	19" rackmount case 3 1/2" high x 9 3/8" deep

## 1.4 ACCESSORIES

Part Number	Description
179215	Dual Source/Sensor Board
179216	Passive I/O Board
179217	IEEE-488 Communication Board
179218	Internal Storage Data/Time Clock
179219	RS-232 to RS-485 conversion
179220	Remote Power Handset
179239	Active I/O Board
180200-4	DCM-200 software 3.5" diskette
123200-5	SH-102 Sensor Head , cables, and carousel of 10 each 6MHz Gold SC-101 sensor crystals
124201-4	SO-100 Oscillator with 6" and 10' BNC Cables.

## MDC-360 DEPOSITION CONTROLLER

---

130200-2	IF-111 Instrument Feedthrough, 1" O-Ring with 1 electrical connector and dual 3/16" water tubes.
130204-2	IF-276 Instrumentation Feedthrough, 2 3/4" Conflat® Flange seal with 1 electrical connector and dual 3/16" water tubes.
150902	SF-120 Combination Sensor Head, Feedthrough, Cables, Crystals and Oscillator.
123204-1	Internal Coax Cable 30".
123204-2	Internal Coax Cable 60".
124202-1	BNC Cable Assembly 10'.
124202-2	BNC Cable Assembly 20'.
124204	BNC Cable Assembly 6".
103220	SC-101 Carousel of 10 each 6MHz gold sensor crystals.
103221	SC-102 Carousel of 10 each 6MHz silver sensor crystals.

Refer to Maxtek Price List for more accessories and other products.



## 2. FRONT PANEL DISPLAYS AND CONTROLS

The front panel is divided into two sections, the operating section and the programming section. The left half of the panel is devoted to the operating displays and controls. The right half is used for programming, viewing stored processes, and displaying the status of the selected process.

### 2.1 OPERATING DISPLAYS

All of the operating displays are updated ten times per second unless the controller is in the Abort mode. When in the Abort mode, the values of the operating displays are held constant so the operator will know the values at the time of the Abort. The controller will also flash the operating displays while in Abort to alert the operator.

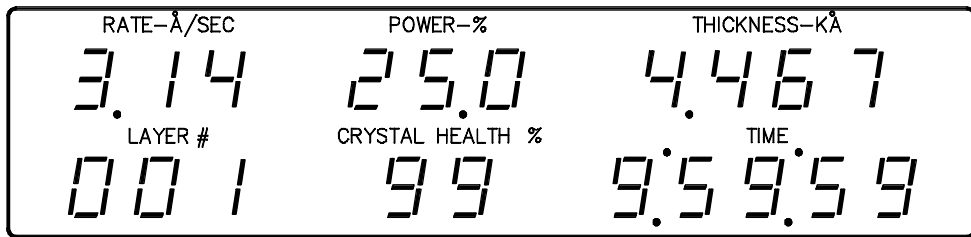

Figure 2-1 Operating Display

#### 2.1.1 RATE

A three digit display with a floating decimal point is used to display deposition rate in angstroms per second at a resolution of 0.1 Å/sec from 0 to 99.9 Å/sec, and a resolution of 1.0 Å/sec for rates from 100 to 999 Å/sec.

#### 2.1.2 POWER

A three digit display with a fixed decimal point displays percent of maximum power with a resolution of 0.1% from 0 to 99.9%. This corresponds to the control voltage range of 0 to 9.99 volts.

#### 2.1.3 THICKNESS

Four digits with an autoranging decimal point display measured thickness in KÅ with a resolution of 1 Å from 0 to 9.999 KÅ, a resolution of 10 Å from 10.00 KÅ to 99.99 KÅ and a resolution of 100 Å from 100.0 KÅ to 999.9 KÅ.

#### 2.1.4 LAYER NUMBER

Three digits display the layer number of the current process.

#### 2.1.5 CRYSTAL HEALTH %

A two digit display is used to show the health percentage of the sensor crystal in use. A fresh crystal starts out with a health of 99%.

**2.1.6 TIME TO GO**

Time To Go is displayed in hours, minutes and seconds. This display can be configured to show the estimated state or layer time or the elapsed process, layer or state times.

**2.2 PARAMETER/STATUS DISPLAYS**

A graphics display labeled Parameter/Status is used for process programming and controller setup as well as displaying run time status and data graphing. The operator can switch between programming screens and status screens by pressing the Program and Status keys on the front panel. Upon power up, the Parameter/Status display automatically reverts to the last viewed status screen. Detail descriptions of the different programming and status screens can be found in Section 4 and 5.

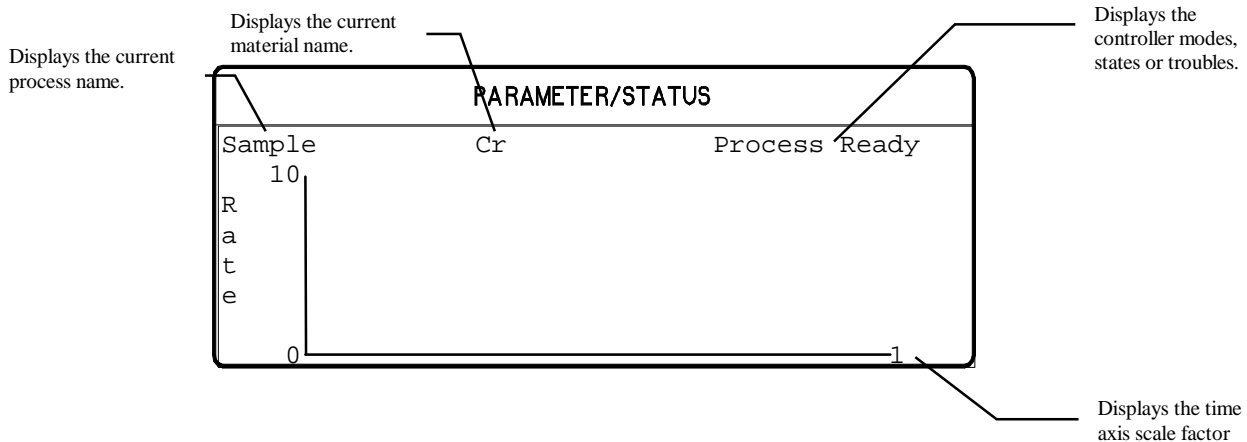

Figure 2-2 Parameter/Status Display

**2.3 OPERATING CONTROLS**

Normal operation of the MDC-360 is controlled by seven operating keys, Manual, Start, Abort, Reset, Zero, Shutter and Status. Except for the Zero and Status keys, each of the other keys is equipped with an LED to indicate the controller's status.

**2.3.1 MANUAL KEY**

This key is used to toggle the MDC-360 Manual mode on and off. A red light behind this key indicates the controller is in manual power control mode. This mode may be selected at any time providing that the controller is not in Abort mode. The Manual mode indicates that the source control voltage output is being controlled through the Remote Power Handset. In the Manual mode the control voltage remains constant unless incremented up or down by means of the Remote Power Handset. At entry into the Manual mode, the power is left at the last value prior to entry and is thereafter modified only through the Remote Power Handset. Exit from the manual mode is accomplished by means of the Manual or Reset key.

The MDC-360 can also be aborted through the Remote Power Handset. This abort feature is active whether or not MDC-360 is in the manual mode.



## 2.3.2 START KEY



The Start key starts a process, starts a layer, or resumes an aborted process. A green light behind this key indicates the controller is in process. When this key is pressed the first time a list of stored processes is displayed in the Parameter/Status window. The up and down arrow keys can be used to move the cursor to the desired process. Press the Start key again to start that process. Note that in many cases messages will be displayed in the Parameter/Status window reminding the operator to check system set up. Follow the prompt.

## 2.3.3 ABORT KEY



The Abort key drives the MDC-360 into the Abort mode. All source powers are set to zero and discrete outputs are set to inactive state. A red light behind this key indicates the controller is in the abort mode.

## 2.3.4 RESET KEY



The Reset key is used to clear the controller from Abort mode and put it into the Ready mode. A yellow light behind this key indicates a Ready mode. The Reset key is inactive during the In Process mode so that a premature exit from the In Process mode requires an abort.

## 2.3.5 ZERO KEY



Pressing the Zero key causes the thickness display to go to zero. This key is active at all times and if pressed during the deposit state will result in a film thicker than that desired by an amount equal to the thickness displayed at the time the display was zeroed.

## 2.3.6 SHUTTER KEY



This key is used to manually open and close all source shutters. The red light is illuminated when the active source shutter relay is closed. This key is only active when the controller is in the Process Ready mode.

## 2.3.7 STATUS KEY



Pressing the Status key will bring up one of the six run-time status screens. Repeatedly pressing the key will cycle through the different status screens. Refer to Section 5 for a detailed description of these status screens.

Figure 2-3 Programming Section

### 2.3.8 ARROW KEYS

The arrow keys are used to navigate through the programming and setup menu structure. These keys will auto-repeat if they are held down for more than half a second.

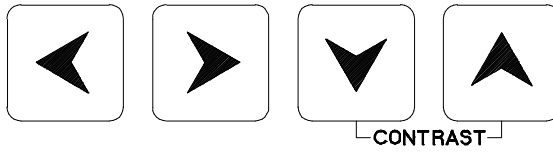

Figure 2-4 Arrow Keys

### 2.3.9 PROGRAM KEY

Pressing the programming key will bring up the last viewed programming screen. If a programming screen is already shown, nothing will happen. This key is also used in conjunction with the Up and Down Arrow keys to adjust the contrast of the Parameter/Status display.



2.3.10 ALPHANUMERIC KEYBOARD

The alphanumeric keyboard is used to edit controller programs. Refer to Section 4 for the use of each key.

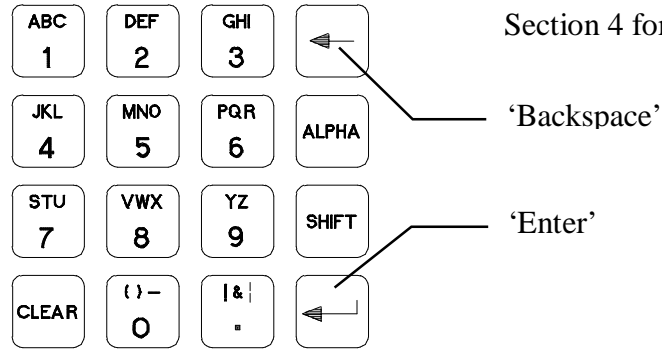

Figure 2-5 Alphanumeric Keyboard



### 3. BENCH CHECKOUT & INSPECTION

#### 3.1 INSPECTION

Your MDC-360 was released to the carrier in good condition and properly packed. It is essential to all concerned that the contents of the shipment be carefully examined when unpacked to assure that no damage occurred in transit. Check the material received against the packing list to be certain that all elements are accounted for. Items included with your controller are:

- 1 MDC-360 Deposition Controller
- 1 Operation and Service Manual
- 1 Power cord
- 1 Source cable (4 pin mini DIN connector)
- 1 Discrete I/O connector kit (37P D shell)

In addition, you may have ordered one or more of the accessories listed in Section 1.4. If there is evidence of loss or damage:

- a) Notify the carrier or the carrier agent to request inspection of the loss or damage claimed.
- b) Keep the shipping containers until it is determined whether or not they are needed to return the equipment to Maxtek.

#### 3.2 INITIAL POWER UP

Upon initial power up the unit will start with all LED's lighted. The Parameter/Status display will show the controller Sign-on screen with its configuration information. The unit will stay in this state until a key is pressed.

When any key on the front panel is pressed, the operating display and the Parameter/Status display will return to the last viewed screen prior to loss of power.

#### 3.3 SAMPLE PROGRAM

The sample program listed below is included in the MDC-360 memory at the time of shipment. It can be used to check out the controller by running it in Simulate mode. Follow instructions in Section 4 to navigate through the menu structure. Check the controller parameter values against the sample program for discrepancy and change if necessary. Note also, if the source or sensor configuration has been changed during familiarization with the controller programming, appropriate source and sensor parameter values also need to be retained for the sample program to run correctly.

Once the sample program has been checked, use the programming Main Menu, Edit System Setup, Edit Utility Setup, to select Simulate mode ON, then use Start to select and run the sample program in Simulate mode.

## MDC-360 DEPOSITION CONTROLLER

---

### 3.3.1 MATERIAL #1 PARAMETERS

Material Name	Cr
Sensor #	1
Crystal #	1
Source #	1
Pocket #	1
Material Density	07.20 gm/cm <sup>3</sup>
Acoustic Impedance	28.95 gm/cm <sup>2</sup> sec
Tooling Factor	70 %
Proportional gain	2400
Integral Time constant	99.9
Derivative Time constant	0.00
Rise to Soak Time	0:00:10 H:MM:SS
Soak Power	5 %
Soak Time	0:00:10
Rise to Predeposit Time	0:00:10
Predeposit Power	9.5 %
Predeposit Time	0:00:05
Rate Establish Time	0 sec
Rate Establish Error	0 %
Deposition Rate #1	10.0 Å/sec
Rate Ramp Start (1 to 4)	999.9 KÅ
Rate Ramp Stop (1 to 4)	999.9 KÅ
Time Setpoint	0
Ramp to Feed Time	0:00:05
Feed Power	7 %
Feed Time	0:00:10
Ramp to Idle Time	0
Idle Power	0
Maximum Power	20 %
Power Alarm Delay	5 sec
Minimum Power	0 %
Rate Deviation Attention	0 %
Rate Deviation Alarm	0 %
Rate Deviation Abort	0 %
Sample Dwell %	100.0 %
Sample Period	0
Crystal Fail	Time Power
Backup Sensor #	1
Backup Tooling Factor	100
Backup Crystal #	1
Material Password	0000

## MDC-360 DEPOSITION CONTROLLER

### 3.3.2 MATERIAL #2 PARAMETERS

Material Name	Au
Sensor #	2
Crystal #	1
Source #	1
Pocket #	2
Material Density	19.30 gm/cm <sup>3</sup>
Acoustic Impedance	23.18 gm/cm <sup>2</sup> sec
Tooling Factor	70 %
Proportional gain	5000
Integral Time constant	99.9
Derivative Time constant	0.00
Rise to Soak Time	0:00:05 H:MM:SS
Soak Power	25 %
Soak Time	0:00:05
Rise to Predeposit Time	0:00:05
Predeposit Power	37.5 %
Predeposit Time	0:00:10
Rate Establish Time	0 sec
Rate Establish Error	0 %
Deposition Rate #1	20.0 Å/sec
Rate Ramp Start (1 to 4)	999.9 KÅ
Rate Ramp Stop (1 to 4)	999.9 KÅ
Time Setpoint	0
Ramp to Feed Time	0:00:05
Feed Power	10 %
Feed Time	0:00:10
Ramp to Idle Time	0
Idle Power	0
Maximum Power	50 %
Power Alarm Delay	5 sec
Minimum Power	0 %
Rate Deviation Attention	0 %
Rate Deviation Alert	0 %
Rate Deviation Alarm	0 %
Sample Dwell %	100.0 %
Sample Period	0
Crystal Fail	Time Power
Backup Sensor #	1
Backup Tooling Factor	100
Backup Crystal #	1
Material Password	0000

### 3.3.3 PROCESS PARAMETERS

Process Name	Layer No.	Thickness	Material
Sample	1	0.400 KÅ	Cr
	2	1.050 KÅ	Au

### 3.4 SIMULATE OPERATION

Testing the MDC-360 is best accomplished by checking its operation in the Simulate mode. This mode can be selected by using the programming Main Menu, Edit System Setup, Edit Utility Setup, to select Simulate mode ON, then use Start to select and run a process in Simulate mode.

The Simulate mode is identical to the Normal mode except that the sensor input is simulated. For this reason, entry to the Simulate mode will extinguish the Crystal Failure message if it is flashing. No other difference between the Simulate mode and the Normal mode occurs until entry to the Deposit State.

### 3.5 MANUAL OPERATION

Manual Mode is selected by depressing the Manual key. The LED behind the key will light up indicating the controller is in Manual mode.

The Manual Mode is identical to the normal mode in all respects except that source power is controlled only through the Remote Power Handset.

The Remote Power Handset has three push buttons, see Figure 3-1. Without any of the buttons depressed, the output power is maintained at its last value. Depressing the "PWR UP" button will increase the power, depressing the "PWR DN" button will decrease the power and depressing the "ABORT" button will put the controller into the Abort mode.

The Abort Mode is active whether or not the MDC-360 is in Manual Mode and therefore can be used as a remote "panic button".

The minimum increment by which the power is increased or decreased is 0.1%.

The Remote Power Handset can also be used to initiate a manual sensor and crystal change by depressing both the power increase and decrease buttons simultaneously. Each time a sensor/crystal switch is initiated, the controller will toggle between the primary and the backup sensor/crystal combination as defined by the active material's parameters. The sensor/crystal switching function is only operational when the controller is not in the Manual Mode.

### 3.6 INSTALLING OPTION BOARDS

Option boards are most easily installed while the MDC-360 is on the bench. **Figure 8-9** shows the location of the various option boards. Also, they are clearly marked on the rear panel.

All Dual Source-Sensor boards are identical, as are all Discrete I/O boards. The input-output configuration of these boards is defined by the position into which

they are installed. One exception for the Discrete I/O boards is that the jumper J2 on the board installed in the Discrete I/O-2 position has to be connected. This is required so the controller will acknowledge the second Discrete I/O board. A Source-Sensor board plugged into the second position will provide sensor inputs numbers 3 & 4, and source outputs numbers 3 & 4. The IEEE-488 board has a single slot.

### 3.6.1 SOURCE-SENSOR BOARD

1. Remove the chassis top cover.
2. Remove the three plastic hole-plugs from the rear panel.
3. Carefully slide the two BNC connectors on the Source-Sensor board into the two top holes on the rear panel. Then with even pressure, push the card edge connector down into the Main board J12.
4. Fasten the two BNC connectors using the nuts and washers supplied with the kit. Make sure the board is properly aligned.
5. Tighten the board down with the tie wrap.
6. Replace the chassis top cover and apply power to the controller.
7. The Sign On screen should acknowledge Source-Sensor 3,4 installed.

### 3.6.2 DISCRETE I/O BOARD

1. Remove the chassis top cover.
2. Locate Discrete I/O-2 slot and remove the slot cover.
3. Carefully slide the D37 connector of the DIO board into the slot and fasten it using the hex fasteners and washers supplied with the kit.
4. Fasten the other end of the board to the standoffs using the two # 4-40 screws provided.
5. Plug the 26-pin ribbon connector into the DIO edge connector J1.
6. Replace the chassis top cover and apply power to the controller.
7. The Sign On screen should acknowledge Discrete I/O-2 installed.

### 3.6.3 IEEE-488 OPTION BOARD

1. Remove the chassis top cover.
2. Locate IEEE-488 option slot and remove the slot cover.
3. Carefully slide the connector of the IEEE-488 board into the slot and fasten it using the fasteners and washers supplied with the kit.
4. Plug the 20-pin ribbon connector into J7 connector on the Main board.
5. Replace the chassis top cover and apply power to the controller.
6. The Sign On screen should acknowledge IEEE-488 option installed.

## 3.7 DIGITAL TO ANALOG CONVERTER (DAC) CHECKOUT

The built-in DAC function on the Main board contains two converters, allowing simultaneous recording of any two of the following four parameters: Rate, Rate deviation, Power and Thickness. The full scale output of each converter is 5 volts, is single ended and is referenced to ground. Parameter selection for each of the channels is accomplished independently by making the appropriate choices in the DAC setup menu.

## MDC-360 DEPOSITION CONTROLLER

---

In addition to the individual channel output pins there are two control pins which are common to both channels and are intended to simplify the process of setting up analog recorders. Connecting the Zero control line to ground will drive both channel outputs to zero, allowing the recorder zero reference to be easily set. Releasing the Zero line and connecting the Full Scale line to ground will drive both channel outputs to full scale for establishing the recorder full scale calibration.

Each channel can be set independently to convert either the two or the three least significant digits of the chosen parameter to a proportional analog signal, corresponding to the DAC setup option chosen. With the three digit setting, a thickness of 0.500 KÅ would result in an analog output of 2.50 volts, or a scale factor of 5 mV/Å. If more resolution is desired, either channel can be configured to convert only the last two digits of the parameter, thus the analog output would achieve full scale at 99Å. The output scale factor in this configuration is 50 mV/Å.

The above scale factors are based on the assumption that the thickness display is in the 0 - 9.999 KÅ range. Because the thickness and rate displays are auto-ranging, the analog output of these variables will also autorange so that in the above example, if the thickness is in the range of 10 KÅ to 99.9 KÅ, the analog scale factor would be 50 millivolts per 10 Å, also ten times larger.

The Rate deviation parameter must be handled differently than the other parameters because it can be negative. Maximum positive error is converted to 5 volts, maximum negative error is converted to 0 volts and zero error is converted to a mid scale, 2.5 volt, output. Maximum corresponds to 99 or 999, plus 1.

The DAC can be checked by putting the MDC-360 into the Simulate mode and checking for correspondence between the analog output and the selected front panel displays.

# MDC-360 DEPOSITION CONTROLLER

---

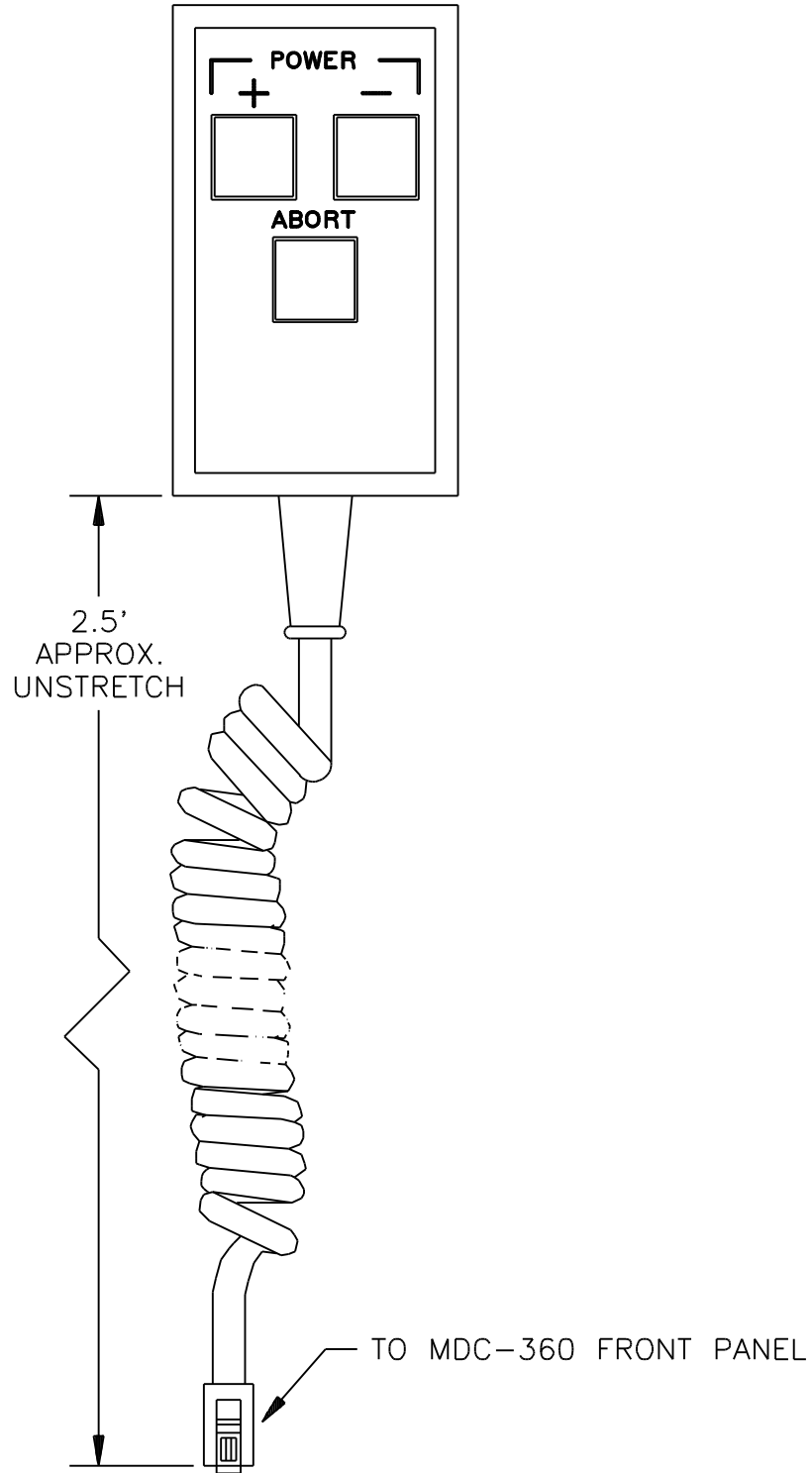

Figure 3-1 Remote Power Handset



## 4. PROGRAMMING AND CONTROLLER SETUP

### 4.1 GENERAL

#### 4.1.1 NAVIGATING THE MENU STRUCTURE

Before attempting to navigate the menu structure of the MDC-360 controller, please refer to Section 2 which provides a brief summary of the front-panel displays and key functions. A graphical menu structure is shown in Figure 15-1. Note that following power-on, and acknowledgment of the Sign-on screen by making any key depression, e.g. Reset, the LCD display will return to the display function being used at the last power-off, i.e. either a status display screen or a programming function screen.

This may be confusing until the full scope of the controller’s capabilities are understood. However, as their names suggest, the Status and Program keys select the display of status information and the display of programming information, respectively.

So, for example, if having chosen the programming functions with a Program key depression there is any doubt about the point in the menu system that is then being displayed, holding down the left-arrow key will eventually display the Main Menu from which point the desired option can be chosen by selective use of the Up-arrow and Down-arrow keys to move the cursors to point to an option, and the Right-arrow key or the Enter key to select the option.

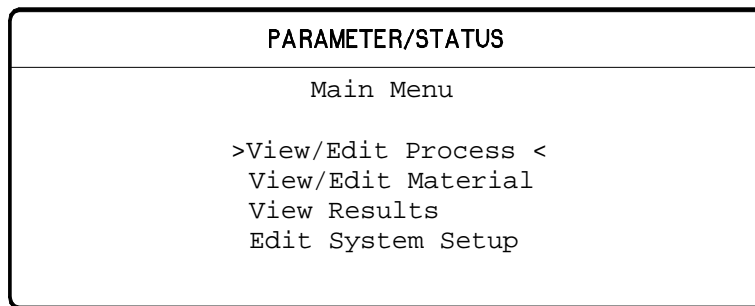

Figure 4-1 The Main Menu

Press the Program key to enter the programming mode. The programming screens can be visualized as a two dimensional menu format. The Main Menu is visualized at the far left, with an increasing level of detail in the menus to the right. The Left and Right-arrow keys are used to move between menus. The Up and Down-arrow keys are used to scroll through a list of parameters or options in each menu. To select a menu option, align the cursors with the option, then press either the Enter key or the Right-arrow key. This will present the next screen associated with the selected option. You can always hold down the Left-arrow

key to go back to the Main Menu. Each of the programming screens is described in detail later in this section.

### 4.1.2 ENTERING ALPHA CHARACTERS

To enter a name, press the key that contains the letter or character you wish to enter. Next, press the Alpha key to change the number to the first letter of that key. Keep pressing the Alpha key to get the desired letter. Its upper/lower case can be toggled by pressing the Shift key. Once the desired letter is achieved, repeat the above procedure and enter the remainder of the name. Note, the number 9 key contains characters Y, Z, and 'space'. Use this key to enter a space.

### 4.1.3 ENTERING TIME PARAMETERS

The MDC-360 expresses time in 24-hour h:mm:ss format. In programming a time parameter, the Decimal '.' key is used to separate hour, minute and second. Hence, 1:45:23 would be entered as "1.45.23" and 0:00:35 entered as "..35", followed by the Enter key.

### 4.1.4 COPYING AND DELETING

A 'process' is defined by one or more 'layers', and a layer requires a 'material' and a thickness definition. The MDC-360 has the capability of copying and deleting processes, layers, and materials. Except when copying a layer, procedures for copying and deleting a process, a layer and a material are the same. The difference when copying a layer is that layers are pushed-down to make space for the new layer, and move up when a layer is deleted.

To copy a process, position the cursor at the process to be copied, then press the number 1 key. Next, move the cursor to the location where the process is to be copied and press Enter. The process will be copied to the new location with the same name. **If there is already a process name at the new location, it will be overwritten.** The copied process should be given a new name to avoid confusion. The same procedure applies when copying a material.

When copying a layer, the copied data will be positioned at the selected layer number. The data of the selected layer, and all following layers, will be pushed down one layer. Example, if a layer is copied onto Layer #4 location, the existing data in Layer #4 will be pushed to Layer #5, Layer #5 to Layer #6, etc., while the copied data is placed in Layer #4.

To delete a process or a material, move the cursor to the item and press the 0 key. A message will pop up asking for verification of the deletion, press 1 to confirm and 0 to cancel the deletion.

### 4.1.5 PASSWORD PROTECTION

Each Process has a View/Run password and an Edit password. Each Material has an Edit password. The three passwords protect against unauthorized operations. The passwords default to 0000, or no password protection, at the time of shipment. Refer to the descriptions below to set each password. **Note: The password protection is only meant to deter unsophisticated users. Be sure to**

**record passwords, because if you forget a password it will not be possible to gain access to the protected item!**

### **4.1.5.1 VIEW/RUN PROCESS PASSWORD**

The View/Run password is required to view or run a process. To set this password, select View/Edit Process from the Main Menu, select the process from the Select Process screen. Move the cursor onto the View/Run password, type in your password (4 digit string), then press the Enter key. A message will pop up asking for verification to change the password. Press 1 to confirm and 0 to cancel the change. Each time you want to view or run this process, you will now be asked to enter the correct password. Note that the Edit Process password takes precedence over the View/Run password. If you know the Edit password, you can also view the process. Once a password other than 0000 has been installed, it will not be displayed unless re-entered.

### **4.1.5.2 EDIT PROCESS PASSWORD**

The Edit process password is required to edit a process. To set this password, select View/Edit Process from the Main Menu, select the process from the Select Process screen. Move the cursor onto the Edit password, type in your password (4 digit string), then press the Enter key. A message will pop up asking for verification to change the password. Press 1 to confirm and 0 to cancel the change. Each time you want to edit this process, you will be asked to enter the correct password. Once a password other than 0000 has been installed, it will not be displayed unless re-entered.

### **4.1.5.3 EDIT MATERIAL PASSWORD**

The Edit material password is required to edit a material. To set this password, select View/Edit Material from the Main Menu, select the material from the Select Material screen. Move the cursor down to the Material Password parameter, the last item in the list, type in your password (4 digit string), then press the Enter key. A message will pop up asking for verification to change the password. Press 1 to confirm and 0 to cancel the change. Each time you want to edit this material, you will be asked to enter the correct password. Once a password other than 0000 has been installed, it will not be displayed unless re-entered.

### **4.1.6 ADJUSTING PARAMETER/STATUS DISPLAY CONTRAST**

The Parameter/Status display contrast can be adjusted by using the Program key in conjunction with the Up-arrow and Down-arrow keys. Hold down the Program key and press the Up-arrow key to increase the contrast. Likewise, hold down the Program key and press the Down-arrow key to decrease the contrast. It may take several seconds for the change in contrast to become apparent.

## 4.2 GETTING STARTED

This section lays out the basic programming sequence with programming examples for initial setup of the MDC-360 deposition controller.

### 4.2.1 UTILITY SETUP

The only critical parameter in the Utility Setup is the Crystal Frequency parameter. This parameter must be set for the specific frequency crystals that you plan to use (2.5, 3.0, 5.0, 6.0, 9.0, 10.0 MHz).

There is one other parameter in the Utility Setup menu that may be useful in the initial setup and testing phase of the MDC-360 and that is the Simulate Mode parameter. The simulate mode of the MDC-360 provides a means of simulating deposition on the crystal. This mode is useful for testing the setup of the MDC-360 without having to deposit any material.

### 4.2.2 DAC SETUP

If the DAC (digital to analog) outputs are to be used then these parameters can be set at this time but it is not necessary for the operation of the controller.

### 4.2.3 SOURCE SETUP

The first item to note is that in defining sources, and sensors for that matter, is that the MDC-360 will automatically create the inputs and outputs necessary to complete the interface based on the parameter settings. Therefore, once the setup is complete, the user should review the inputs and outputs noting the pin assignments so that the proper connections can be made. Also note that the I/O pin assignments can be changed if necessary in the program input and output screens.

The user must also be aware of the type of I/O card installed in the MDC-360. There are two types of I/O cards available. Both cards have the same 9 relay outputs (8 programmable and 1 abort) and the same number of inputs (8 programmable). The difference is the standard card has TTL ground true inputs while the Active I/O card has 115VAC high true inputs. The Active I/O card is designated by “Active I/O Card” written on the rear panel of the MDC-360.

The following two items in the Source Setup are common to almost all types of sources and typically require definition:

**Source Shutter** - If the source has a shutter to be activated by the MDC-360 then the Shutter Relay Type parameter must be set to either N.O. (normally open) or N.C. (normally closed). The typical setting is N.O. which means that the relay will close to open the shutter.

Once defined, the MDC-360 will create a relay output called “SourceN Shutter” that should be connected to the shutter actuator. The shutter can be tested by pressing the Shutter key with the controller in the Process Ready state. When the red LED in the Shutter key is illuminated then all source shutters should be opened. When the shutter LED is off then all source shutters should be closed.

If the shutter actuator has a significant delay in opening and closing then set the Shutter Delay parameter equal to the delay.

**Source Voltage** - This parameter must be set to correspond to the input voltage range of the source power supply (0 to 2.5, 5.0 or 10.0 volts).

The settings of the rest of the source parameters are dependent on whether the source has one or more pockets (crucibles) and whether pocket selection is manual or automatic.

**Single Pocket Source** - If the source has only one pocket (single pocket E-beam gun, filament boat or sputtering source) then the remaining parameters can be left at their default values.

**Multiple Pocket Source with Manual Position Control** - For manual position control of a multiple pocket source, you need only set the Number of Pockets parameter to the correct number of pockets. Once set, a message will appear at the start of each layer instructing the operator to change source N to the required material.

**Multiple Pocket Source with Automatic Position Control** - There are two parameters requiring definition which are common to all the various types of position control. The first is the Number of Pockets parameter and the second is the Rotator Delay parameter. The Number of Pockets parameter is simply the number of pockets in the source. The Rotator Delay parameter defines the maximum amount of time allowed for the correct pocket to rotate into position. This should be set to the time it takes for the rotator to go from pocket #1 all the way around to pocket #1 again.

The settings of the three remaining parameters required for automatic pocket position control depend on the required type of position control and position feedback.

**Position Control** - The MDC-360 can be setup to either control the pocket position directly by interfacing to the rotator's actuator or indirectly by interfacing to a rotator controller.

**Direct Control of Pocket Position** - Direct control means that the MDC-360 will control the actuator (rotator motor, pneumatic valve, etc.) directly to get the desired pocket into position. For direct control first set the Control Parameter to Direct then select one of the following drive types and follow the instructions:

- a. **Unidirectional Motor Drive** - The rotator drive motor can only turn in one direction. Select Up for the Drive parameter. A relay output will be created called "SourceN Drive Up" that should be connected between the rotator motor and power supply.
- b. **Bi-directional Motor Drive** - The rotator motor can turn in either direction. Select Fast for the Drive parameter. Two relay outputs will be created. One called "SourceN Drive Up" and one called "SourceN Drive Dn". With this drive type, the MDC-360 will

activate either the drive up or drive down outputs to rotate to the required pocket in the least amount of time.

- c. **Motor Driven Inline Source** - Select Inline for the Drive type parameter. Two relay outputs will be created. One called “SourceN Drive Up” and one called “SourceN Drive Dn”. In this case the up output will be activated when going from the greatest pocket to pocket #1.
- d. **Unidirectional Pneumatic Drive** - Select Sngl Step or Dbl Step for the Drive parameter. A relay output will be created called “SourceN Drive Up” that should be connected between the rotator’s pneumatic valve and power supply. With Sngl Step, the output will pulse once for one second to increment the rotator one position. With Dbl Step, the output will pulse twice for one second each to increment the rotator one position.

**Indirect Control of Pocket Position** - Indirect control means that the MDC-360 will indicate the desired pocket position to a pocket rotator controller through position select outputs. The Drive parameter selects between the two following indirect position output formats:

- a. **Individual** - With individual format, one output will be created for each pocket. So, if pocket 2 is the desired pocket, then the output “SourceN Pocket 2” will be true while all the other position outputs will be false.
- b. **BCD** - With BCD format, the MDC-360 will create from one to three outputs based on the number of pockets. For example, an eight pocket source would use three outputs. If pocket one is the desired pocket, all outputs will be false. If pocket four is the desired pocket, outputs one and two will be true and output three will be false.

**Position Feedback** - The last step in defining automatic control of a multi-pocket source is to select the pocket position feedback type. The MDC-360 has the following five types of position feedback available:

**No Feedback** - As the name implies, no position feedback is created for this type.

**Individual** - For this feedback type, one input is created for each pocket position in the source. The inputs are labeled “SourceN Pocket X”. All inputs are normally false (open circuit) unless the respective pocket is in position then that input should be true (closed to ground). For example, a six pocket source would use six inputs. If pocket two was in position then all the inputs should be false except the input connected to “SourceN Pocket 2”.

Individual position feedback is the most typical feedback type and is recommended if more than one type is available.

**BCD** - Binary Coded Decimal position feedback. This feedback type uses binary coding to indicate the pocket position. Inputs are numbered most significant bit first. For example, an eight pocket source would use three inputs. With pocket one in position, all inputs will be false. With pocket four in position, inputs one and two will be true and input three will be false.

**SNGL HOME** - Single home position feedback. This feedback type uses one input. The input is normally false (open circuit) and should go true (closed to ground) when pocket one is in position.

**IN POSITION** - In position feedback. This feedback type uses one input. The input is normally false (open circuit) and should go true (closed to ground) when the desired pocket is in position.

#### 4.2.4 SENSOR SETUP

The following examples demonstrate how the MDC-360 is setup to control the four basic types of crystal sensor heads available:

**Single Crystal Sensor Head** - No sensor parameters need to be changed for a single crystal sensor head.

**Single Crystal Sensor Head with Shutter** - For a single shuttered sensor head, set the Shutter Relay Type parameter to either N.O. (normally open) or N.C. (normally closed). The typical setting is normally open which means that the relay will close to open the shutter. A relay output called "SensorN Shutter" will be created that should be connected between the sensor shutter actuator and power supply.

**Dual Crystal Sensor Head with Shutter** - For a dual crystal shuttered sensor head, set the Shutter Relay Type parameter to Dual. A relay output called "DualSnsr1&2 Shtr" will be created that should be connected between the sensor shutter actuator and power supply.

Automatic crystal switching upon failure is enabled in the material menu by setting the Crystal Fail parameter to Switch and the Backup Sensor number to 2. Note that with the dual sensor head you define the sensor number that you would like to use, (or switch too) not the crystal number. The crystal number need only be defined when you are using a multiple crystal sensor head(sensor head with one BNC output and more than one crystal).

**Multiple Crystal Sensor Head** - The MDC-360 can be setup for either automatic or manual control of multiple crystal sensor heads.

- a. **Manual Crystal Position Control** - For manual crystal position control of a multiple crystal sensor head, set the Number of Crystals parameter to the correct number of crystals. Once set, a message will appear at the start of each layer instructing the operator to change sensor N to the required crystal number.

b. **Automatic Crystal Position Control** - There are two parameters requiring definition which are common to all the various types of multiple sensor heads. The first is the Number of Crystals parameter and the second is the Rotator Delay parameter. The Number of Crystals parameter defines the number of crystals in the sensor head. The Rotator Delay parameter defines the maximum amount of time allowed for the correct crystal to rotate into position. This should be set to the time it takes for the rotator to go from crystal #1 all the way around to crystal #1 again.

The settings of the three remaining parameters required for automatic crystal position control depend on the type of position control and position feedback.

**Position Control** - The MDC-360 can be setup to either control the crystal position directly by interfacing to the rotator's actuator or indirectly by interfacing to a rotator controller.

**Direct Control of Pocket Position** - Direct control means that the MDC-360 will control the actuator (rotator motor, pneumatic valve, etc.) directly to get the desired crystal into position. For direct control, set the Control Parameter to Direct then select one of the following drive types and follow the instructions:

- a. **Unidirectional Motor Drive** - Select Up for the Drive parameter. A relay output will be created called "SensorN Drive Up" that should be connected between the rotator motor and power supply.
- b. **Bi-directional Motor Drive** - Select Fast for the Drive parameter. Two relay outputs will be created. One called "SensorN Drive Up" and one called "SensorN Drive Dn". With this drive type, the MDC-360 will activate either the drive up or drive down outputs to get to the required crystal in the least amount of time.
- d. **Unidirectional Pneumatic Drive** - Select Sngl Step or Dbl Step for the Drive parameter. A relay output will be created called "SensorN Drive Up" that should be connected between the rotator's pneumatic valve and power supply. With Sngl Step, the output will pulse once for one second to increment the rotator one position. With Dbl Step, the output will pulse twice for one second each to increment the rotator one position.

**Indirect Control of Crystal Position** - Indirect control means that the MDC-360 will indicate the desired crystal position to a crystal rotator controller through position select outputs. The Drive parameter selects between the two following indirect position output formats:

- a. **Individual** - With individual format, one output will be created for each crystal. So, if crystal 2 is the desired crystal, then the

output “SensorN Crystal2” will be true while all the other position outputs will be false.

b. **BCD** - With BCD format , the MDC-360 will create from one to three outputs based on the number of crystals. For example, an eight crystal sensor head will use three outputs. If crystal one is the desired crystal, all outputs will be false. If crystal four is the desired crystal, outputs one and two will be true and output three will be false.

#### 4.2.4.1 EXAMPLE USING MAXTEK’S RSH-600 SIX CRYSTAL SENSOR HEAD

The following is a list of the sensor parameter settings required to control Maxtek’s RSH-600 six crystal sensor head.

Number of Crystals	-	6
Shutter Relay Type	-	None
Control	-	Direct
Drive	-	Sngl Step
Feedback Type	-	Indiv
Rotator Delay	-	30

With the above parameter settings, the MDC-360 will create six position feedback inputs called “SensorN CrystalX” where X ranges from 1 to 6. These inputs should be connected to the six position feedback pins on the RSH-600 sensor head. Pin #1 of connector J1 on the sensor head should be connected to the “SensorN Crystal1” input on the MDC-360. Pin #2 on the sensor head should be connected to “SensorN Crystal2” on the MDC-360 and so on. Pin #7 on the sensor head should be connected to pin #12 or any of the return pins when using the standard 360 I/O board. When using the 360 Active I/O board then pin #7 of the sensor head should be connected to one side of a 115VAC source. The other side of the 115VAC source should be connected to the other side of the six position feedback inputs on the 360.

#### 4.2.5 INPUT, OUTPUT AND ACTION SETUP

The MDC-360’s inputs, outputs and actions can be used to provide control for, or an interface to all sorts of vacuum system peripherals such as PLC system controllers, substrate heaters, planetary rotators, etc. If your system doesn’t require any special interfacing or control then you can skip to the next section.

The following are a few examples of some typical uses for the MDC-360’s programmable I/O’s and actions.

**Optical Monitor Termination** - To setup the MDC-360 to terminate the deposit on a signal from an optical monitor, the first step is to program an input that will be connected to an output in the optical monitor. Go to the Program Inputs screen and select a blank input. Name the input “Optical

Monitor” for future identification. Note the I/O card and the pin numbers of the input so you can later connect the input to the optical monitor.

Next, go to the Program Actions screen and select any action labeled “No Action”. Press the right arrow key with the cursor on the action Name parameter and select the TerminateDeposit action. Move the cursor to the Conditions field and press the 0 key to add a condition. Move the cursor down to the Input condition type, press the right arrow key, move the cursor onto the “Optical Monitor” input and press enter. Press enter again to complete the condition string.

Now, the MDC-360 will terminate the deposit whenever the “Optical Monitor” input is set true by the optical monitor.

**Substrate Heat Control** - To create an output in the MDC-360 to switch on and off a substrate heat controller, first go to the Program Outputs screen and select a blank output. Name the output “Substrate Heat” for future identification. Note the I/O card number and the pin numbers of the output so you can later connect the output to the substrate heater controller.

Next, move the cursor onto the Conditions field and press the 0 key to add a condition. With the cursor on the State condition type, press the right arrow key and select the state in which you would like the heater to first turn on. If you would like the heater on during more than the one state, then press the 5 key to add an or “|” symbol then press 0 to add the next desired state. Repeat this process until all of the states requiring substrate heat have been added to the condition. For example, if you would like substrate heat to start in the Predeposit Hold state and continue through the Deposit 1 state then your condition string would look like this “Predeposit Hold|Deposit 1”.

With the condition string completed, the MDC-360 will set this output true when ever it is in the selected states.

### 4.2.6 DISPLAY SETUP

The only parameter in the Display Setup menu that affects the controller’s function is the Pause On Layer Complete parameter. This parameter determines whether or not the controller will pause at the completion of each layer. When set to Yes, the controller will stop at the end of each layer and wait for a Start key press before continuing. When set to No, the controller will immediately go to the next layer.

### 4.2.7 MATERIAL SETUP

The next step in the initial setup of the controller is to define the materials that you wish to deposit. Because of its many features, the MDC-360 has a long list of material parameters which at first can be overwhelming. Fortunately, the default settings of most parameters are such that the feature they define is disabled when left at the default. This section will list the material parameters typically set for

all materials and the parameters which must be set to utilize the different features of the MDC-360. For a detailed description of any material parameter, go to Section 4.3.2.1.

The following is a list of the material parameters that are typically set when defining a new material:

**Process Name** - If you select a material from the default material library (press the right arrow key from the material name parameter and press enter on the desired material) then the density and acoustic impedance for that material will be entered automatically. If your material is not in the library then you must enter the name, density and acoustic impedance.

**Sensor input and crystal number** - Defines the sensor and crystal number of the sensor which will be used to monitor this material.

**Source output and pocket number** - Defines the source and pocket number of the source that the material will be deposited from.

**Tooling Factor** - Used to correlate the controller's rate and thickness readings with those on the substrates. This parameter is determined empirically.

**Control loop parameters (Proportional Gain, Integral Time, Derivative Time)**.  
The default settings for these parameters are a good starting point.

**Deposit Rate #1** - Defines the target deposit rate for the material.

**Maximum Power** - Defines the maximum deposit power for the material.

The above parameters are typically all that are needed to deposit the most basic materials. If no other features are required then the remaining parameters can be neglected. The following is a list of the more specialized features defined by the material parameters. All of the features are disabled by default.

### **4.2.7.1 POWER RAMPS**

Power ramps are used for source material conditioning prior to and after the deposit states. A power ramp is defined by a ramp time, a ramp too power level and a hold time before the next state. There are two power ramps available prior to and one after the deposit states. The first ramp prior to deposit is the soak and the second is the predeposit. If only one ramp is needed prior to deposit then you should use the predeposit ramp. The power ramp after the deposit states is called the Feed.

The parameters used to define the three power ramps are as follows:

**Soak Power Ramp** - Rise to Soak Time, Soak Power and Soak Time

**Predeposit Power Ramp** - Rise to Predeposit Time, Predeposit Power and Ramp to Feed Time

**Feed Power Ramp** - Ramp to Feed Time, Feed Power and Feed Time

### 4.2.7.2 AUTOMATIC CRYSTAL SWITCHING

To enable automatic Crystal switching upon failure, set the Crystal Fail parameter to Switch then set the Backup Sensor, Backup Tooling and Backup Crystal parameters to define the backup sensor and crystal.

### 4.2.7.3 RATE ESTABLISH

The rate establish feature is used in critical processes where it is important to establish the correct deposition rate prior to opening the source shutter and depositing on the substrates. To use this feature, the sensor head must be mounted in such a way that it is in the material vapor stream with the source shutter either opened or closed.

To enable this feature you must set the Rate Estab. Time and Rate Estab. Error parameters. The Rate Establish Time parameter sets the maximum time that the controller will attempt to keep the rate error within the Rate Estab. Error limit for a period of five seconds. If the rate error condition is met within the allotted time then the controller will enter the deposit state. If not, then the process will be halted and a Rate Establish Error will be displayed.

### 4.2.7.4 RATE RAMPS

Rate ramping is typically used at the beginning of the deposition to ease the rate up slowly to prevent material spitting. Rate ramping is also used towards the end of the deposition to achieve a more accurate endpoint thickness. By slowing down the rate, the thickness overshoot caused by the delay of the shutter closing is diminished.

The MDC-360 has four rate ramps available. A rate ramp is defined by its Ramp Start and Ramp Stop Thicknesses and the final rate.

The rate ramps are disabled by default with the Ramp Start and Ramp Stop Thicknesses set to 999.9.

### 4.2.7.5 RATE SAMPLE MODE

Rate sample feature is designed for large deposition thicknesses where crystal life is a problem. . By sampling the rate periodically to maintain rate control, then closing the sensor shutter with the rate and power level constant, a large deposition thickness can be achieved with one crystal.

To enable the rate sample feature, set the Sample Dwell% parameter to the percentage of time you wish the controller to sample the rate. Then set the Sample Period parameter to the time period of the sample and not sampling period.

### 4.2.7.6 RATE DEVIATION ALARM

The MDC-360 provides three rate deviation levels to trigger an attention sound, an alarm sound, or a process abort. The attention and alarm sounds are momentarily triggered meaning they will sound when the error is exceeded and

clear when within the limit. The process will abort when the abort level is exceeded and the power is at the maximum or minimum power.

### **4.2.8 PROCESS SETUP**

The final step in the initial setup of the controller is to define the processes that you wish to run. To define a process you should complete the following steps:

Select a blank process from the Select Process Screen. Please note that you can also copy and modify a similar process to save time.

Enter a process name in the Define Process Screen.

Move the cursor onto the layer thickness parameter and enter the desired thickness for the layer.

Select a material for the layer by moving the cursor onto the material column, pressing the right arrow key, moving the cursor onto the desired material for the layer and pressing the Enter key.

Repeat steps c&d until the process layers are complete.

### **4.2.9 STARTING A NEW PROCESS**

To start a new process, the controller must be in the Process Ready state. If not, press abort then reset. From the ready state, press the start key, move the cursor onto the desired process and press start again to start the process.

### **4.2.10 RESUMING A PROCESS FROM ABORT OR HALT**

To resume an aborted process, first press the start key. A message will appear asking you to press the start key again to resume the process. The process will resume from the layer where the process was aborted starting in either the Rise to Soak or Rise to Predeposit power states. Once in deposit, the thickness will continue from the last value prior to the abort.

## **4.3 DETAILED PROGRAMMING**

### **4.3.1 VIEW/EDIT PROCESS**

Selecting View/Edit Process from the Main Menu will present the Select Process screen to delete, copy, view or edit any one of up to 99 processes.

To select a process for viewing and editing, move the cursor onto the desired process using the Up-arrow and Down-arrow keys, then press the Enter key.

PARAMETER/STATUS			
Select Process:	01	>Cr	<
	02	Au	
	03		
	04		
	05		
1	- Copy process	06	
0	- Delete process	07	
←	- View/Edit process	08	↓

Figure 4-2 Select Process screen

4.3.1.1 DEFINE A PROCESS

PARAMETER/STATUS				
Process Name	Layer#	Thickness	Material	
>Sample	<	001	0.500	Cr
Edit	0000	002	1.350	Au
View/Run	0000	003	0.000	End Layer
		004	0.000	End Layer
		005	0.000	End Layer
		006	0.000	End Layer
		007	0.000	End Layer

Figure 4-3 Define Process screen

Selecting a process will bring up the Define Process screen as shown in Figure 4-3. In this screen you enter all of the parameters that define a process. A process consists of a twelve-character name, two levels of passwords and finally a sequence of layers that makeup the process. Each layer consists of a material and the desired thickness for the layer. A process can have from 1 to 999 layers as long as the total number of layers in all the processes is not greater than 999. The following list describes all of the process parameters:

**Process Name** (twelve character alphanumeric field)

Each process is referenced by a twelve-character alphanumeric process name. You enter a process name using the alphanumeric keypad as described in ENTERING ALPHA CHARACTERS section 4.1.2. Please note that the active process name is displayed in the upper left-hand corner of all the status screens.

**Edit Password** (four character alphanumeric field)

The Edit process password allows you to lock out other users from editing a process unless the correct password is known. To set this password, move the cursor onto the Edit password field, type in your password then press the Enter key. A message will pop up asking for verification to change the password. Press

1 to confirm and 0 to cancel the change. Each time you want to edit this process, you will be asked to enter the correct password. Once a password has been entered, this parameter will not be displayed until the password has been entered again.

The default for this parameter is '0000'.

**Please note that once the password has been changed, the process cannot be modified unless the correct password is entered so you must remember your passwords.**

### **View/Run Password** (four character alphanumeric field)

The View/Run process password allows you to lock out other users from viewing and/or running a process unless the correct password is known. To set this password, move the cursor onto the Edit password field, type in your password then press the Enter key. A message will pop up asking for verification to change the password. Press 1 to confirm and 0 to cancel the change. Each time you want to view or run this process, you will be asked to enter this password. Please note that the view function of this password is ignored if the Edit Password is not set. Once a password has been entered, this parameter will not be displayed until the password has been entered again.

The default for this parameter is '0000'.

**Please note that once the password has been changed, the process cannot be viewed or run unless the correct password is entered so you must remember your passwords.**

### **Layer** (000 to 999)

This column shows the layer number in the process. Please note that with the cursors on a layer number you can copy or delete this layer.

### **Thickness** (000.0 to 999.9)

This parameter defines the desired thickness for the layer. The default for this parameter is 0.000 Kang.

### **Material**

This parameter defines the material for this layer. The layer material is selected from the list of materials defined in View/Edit material. Therefore, you should define all of the necessary materials for the process before defining the process. See EDIT MATERIAL PASSWORD section 4.3.2.

To select a material, move the cursors to the material parameter for that layer and press the Right-arrow key. The Select Layer Material screen will be displayed as shown below. Scroll to the desired material and press Enter.

The layer material defaults to 'End Layer' meaning this layer marks the end of the process.

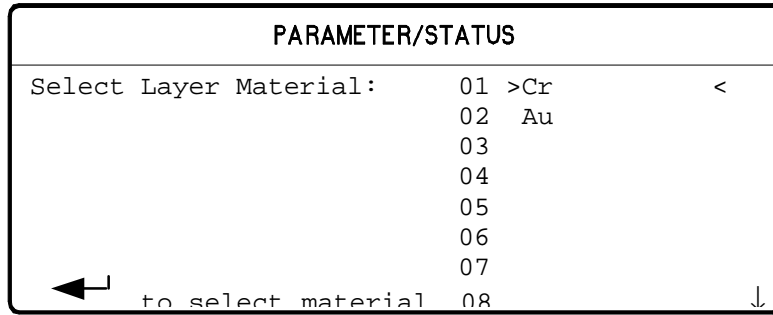

Figure 4-4 Select Layer Material screen

#### 4.3.2 VIEW/EDIT MATERIAL

From the Main Menu, selecting View/Edit Material will present the Select Material screen shown below.

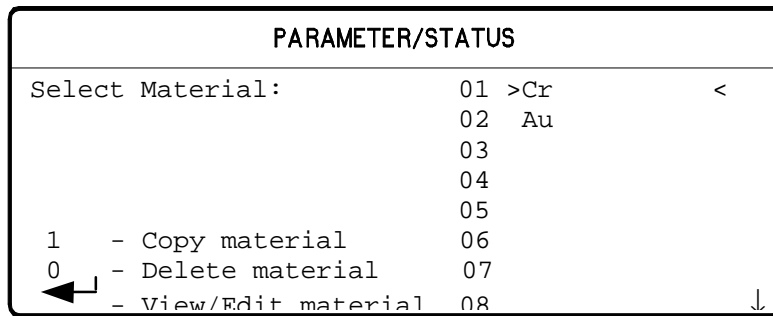

Figure 4-5 Select Material screen

#### 4.3.2.1 DEFINE A MATERIAL

Selecting a material for viewing and/or editing will present the screen which permits the material to be defined, shows the first page of this screen. In this screen, you define all of the material parameters for the selected material. The material parameters are described in detail below.

PARAMETER/STATUS		
Material Name:	>Cr	<
Sensor	1	
Crystal	1	
Source	1	
Pocket	1	
Density	07.20	gm/cm <sup>3</sup>
Acoustic Impedance	28.95	gm/cm <sup>2</sup> /sec
Tooling Factor	070 0	% ↓

Figure 4-6 Define Material screen

**1. Material Name** (A ten character material name)

The material name parameter allows you to either use the keypad to type in a name, or pick a name from the materials already stored in the material library.

To pick a material from the material library, move the cursor to the material parameter and press the Right-arrow key. This will display a complete list of materials that are stored in the MDC-360. To pick a material, move the cursor onto that material and press Enter key. Once a material is chosen, the stored values for the density and acoustic impedance for that material are automatically entered into their respective parameters.

**2. Sensor#** (1 to 4)

This parameter defines the sensor input number that will be used for this material, and cannot be greater than the number of sensor inputs fitted to the controller. The default setting is 1.

**3. Crystal#** (1 to 8)

This parameter defines the primary crystal used to monitor this material. This parameter cannot be greater than the Number of Crystals parameter in the Sensor Setup screen. . The default setting is 1.

**4. Source#** (1 to 4)

This parameter defines the source output number that will be used for this material, and cannot be greater than the number of source outputs fitted to the controller. The default setting is 1.

**5. Pocket#** (1 to 8)

This parameter defines the pocket number that contains this material. This parameter cannot be greater than the Number Of Pockets parameter in the Source Setup screen. The default setting is 1.

**6. Density** (0.80 to 99.99 gm/cm<sup>3</sup>)

This parameter provides the material density so that the controller can calculate and display the physical film thickness. If the film density is known it should be

used. A list of the more commonly used film densities is presented in **Table 10-1**. As a first approximation, bulk material density can be used in programming. Empirical calibration of this parameter is described in Section 10.6.1.

### **7. Acoustic Impedance** (0.50 to 59.99 gm/cm<sup>2</sup>/sec)

This parameter is the acoustic impedance of the material. The acoustic impedance of the deposited film is required by the MDC-360 in order to accurately establish the sensor scale factor when the sensor crystal is heavily loaded. If the acoustic impedance of the film material is known, it can be entered directly in units of 10<sup>5</sup> gm/cm<sup>2</sup> sec. In most cases the acoustic impedance of the bulk material can be used and can be obtained from The Handbook of Physics or other source of acoustic data. The shear wave impedance should be used. The shear wave acoustic impedance can be calculated from the shear modulus or the shear wave velocity and the density by using the following equation:

$$AI = r \cdot C = \sqrt{r \cdot G}$$

Where:

AI= Acoustic Impedance

r= Density (gm/cm<sup>3</sup>)

C= Transverse (shear) wave velocity (cm/sec)

G= Shear Modulus (dynes/cm<sup>2</sup>).

A list of the acoustic impedance and density of the more commonly deposited materials is presented in **Table 10-1** and a technique for empirically determining this parameter is presented in Section 10.6.3.

In many cases and particularly if the sensor crystal is not heavily loaded, sufficient accuracy can be achieved by using the acoustic impedance of quartz which is 8.83 X 10<sup>5</sup> gm/cm<sup>2</sup> sec.

### **8. Tooling Factor** (10.0 to 499.9%)

This parameter is the tooling factor for the primary sensor. The Tooling Factor parameter is used to compensate for geometric factors in the deposition system which result in a difference between the deposition rate on the substrates and the rate on the sensing crystal. This parameter is entered in percent units and 100% corresponds to equal rates at the substrate and at the sensing crystal. To a first approximation the tooling factor can be calculated using the following equation:

$$Tooling\% = \left( \frac{dc}{ds} \right)^2 \cdot 100$$

where:

dc= Distance from source to crystal.

$ds$ = Distance from source to substrate.

Empirical calibration of the tooling factor is described in Section 10.6.2.

### **9. Proportional Gain** (0 to 9999)

This parameter is the proportional gain factor for the source power control loop.

### **10. Integral Time constant** (0 to 99.9 sec)

This parameter is the system time constant.

### **11. Derivative Time constant** (0 to 99.9 sec)

This parameter is the system dead time.

### **12. Rise To Soak Time** (0 to 9:59:59)

This parameter sets the time interval for the source power to ramp up from zero to the power level set in Soak Power parameter. It should be long enough for the material to have time to reach equilibrium temperature without spitting, or in the case of evaporation sources, protected from unnecessary thermal shock.

### **13. Soak Power** (0.0-99.9%)

This parameter defines the source power level during the Soak state. The Soak Power should be established at a level which will assure that the source material is properly outgassed and prepared for subsequent deposition.

### **14. Soak Time** (0 to 9:59:59)

The Soak Time parameter defines the time duration of the Soak state. It is used in conjunction with the Soak Power to allow the material to fully outgas.

### **15. Rise To Predeposit** (0 to 9:59:59)

This parameter sets the time interval for the source power to ramp from Soak Power level to the Predeposit Power.

### **16. Predeposit Power** (0.0 to 99.9%)

This parameter defines the source power level during the Predeposit state. This should be set as close as possible to the power level required to reach the desired deposition rate. The Manual mode can be used to conveniently determine the Soak and Predeposit power levels of a particular material.

### **17. Predeposit Time** (0 to 9:59:59)

This parameter defines the time duration of the Predeposit state. The Predeposit Time should be established at a value which allows the source material to be brought to the deposit temperature level and stabilized in an orderly manner. Since evaporation will normally occur at the Predeposit power level, too long a Predeposit Time will result in unnecessary buildup of material on the shutter and unnecessary material loss.

### **18. Rate Establish Time** (0 to 99 seconds)

This parameter defines the time limit of the rate establish state. The rate establish state occurs before the deposit state and is used to establish the correct source

power before the source shutter is opened. In the rate establish state the crystal shutter is opened, the source shutter is closed, and the controller is controlling source power to achieve the programmed rate within the Rate Establish Error% for a period of 5 seconds. Once the rate has been held within limit for 5 seconds, the controller will go into the deposit state. If the rate error cannot be held within the allowed percentage error for 5 seconds, then the controller will display a Rate Establish Error and the process will be halted.

For the rate establish function to work, the sensor must be located somewhere in the vapor stream of the source while the source shutter is closed. The default setting for this parameter is 0 which disables this function.

**19. Rate Establish Err% (0 to 99%)**

This parameter sets a maximum limit for the rate establish error, which must not be exceeded for a five-second period during the rate establish state, in order for the controller to enter the deposit state.

**20. Deposit Rate #1 (0.0 to 999.9 Å/sec)**

This parameter defines the first deposition rate.

**21. Ramp Start Thk #1 (0.000 to 9999.)**

This parameter determines the thickness value to trigger the start of the first rate ramp. A value of 999.9 will disable the rate ramp function. Please note that all the Ramp Start Thk parameters can also be used as thickness setpoints for triggering I/O events.

**22. Ramp Stop Thk #1 (0.000 to 999.9)**

This parameter defines the ending thickness for rate ramp #1.

**23. Deposit Rate #2 (0.0 to 999.9 Å/sec)**

This parameter defines the second rate.

**24. Ramp Start Thk #2 (0.000 to 9999.)**

This parameter determines the thickness value to trigger the start of the second rate ramp. A value of 999.9 will disable the rate ramp function.

**25. Ramp Stop Thk #2 (0.000 to 999.9)**

This parameter defines the ending thickness for rate ramp #2.

**26. Deposit Rate #3 (0.0 to 999.9 Å/sec)**

This parameter defines the third deposition rate.

**27. Ramp Start Thk #3 (0.000 to 9999.)**

This parameter determines the thickness value to trigger the start of the third rate ramp. A value of 999.9 will disable the rate ramp function.

**28. Ramp Stop Thk #3 (0.000 to 999.9)**

This parameter defines the ending thickness for rate ramp #3.

**29. Deposit Rate #4 (0.0 to 999.9 Å/sec)**

This parameter defines the fourth deposition rate.

**30. Ramp Start Thk #4** (0.000 to 9999.)

This parameter determines the thickness value to trigger the start of the fourth rate ramp. A value of 999.9 will disable the rate ramp function.

**31. Ramp Stop Thk #4** (0.000 to 999.9)

This parameter defines the ending thickness for rate ramp #4.

**32. Time Setpoint** (0 to 9:59:59)

This parameter defines the time from the start of the layer until the time setpoint event is triggered.

**33. Ramp To Feed Time** (0 to 9:59:59)

This parameter defines the time allowed for the source power to go from the last deposition power to the Feed Power. The default for this parameter is zero.

**34. Feed Power** (00.0 to 99.9%)

The Feed Power parameter defines the source power level during the feed state.

**35. Feed Time** (0 to 9:59:59)

The Feed Time parameter sets the feed time. This parameter can also be used as a delay between the deposit state and the idle state. The default for this parameter is zero which disables the feed function.

**36. Ramp To Idle Time** (0 to 9:59:59)

This parameter defines the time allowed for the source power to go from the last deposition power or feed power to the Idle Power. The default for this parameter is zero.

**37. Idle Power** (00.0 to 99.9%)

This parameter defines the source power after the feed or deposit states until the next Soak or abort state. If the idle power is greater than zero then the next layer using this source and pocket will start from the Predeposit state. If any subsequent layer uses the same source but a different pocket, the idle power will be automatically set to zero.

**38. Maximum Power** (00.0 to 99.9%)

The maximum power parameter sets the maximum allowable source power for this material. The deposition power will not be allowed to exceed this value.

**39. Power Alarm Delay** (0 to 99)

This parameter sets the time required for the deposit power to be at Maximum or Minimum power before the alarm will be triggered.

**40. Minimum Power** (00.0 to 99.9%)

This parameter sets the minimum power level for the minimum power warnings. If the power is at or below this level during a deposit a Minimum Power attention warning will be given. If this condition remains true for longer than the time set

by the Power Alarm Delay parameter then a Minimum Power Alert warning will be given.

### **41. Rate Dev. Attention (00.0 to 99.9%)**

The rate deviation attention parameter sets the allowable percent deviation from the deposition rate. If the deposition rate deviates by more than this percentage during the deposition, then a rate deviation attention message will be displayed in the Parameter/Status display. The default setting of 00.0% disables this function.

### **42. Rate Dev. Alarm (00.0 to 99.9%)**

This parameter sets the percent deviation from the deposition rate required to trigger a rate deviation alarm. The default setting of 00.0% disables this function.

### **43. Rate Dev. Abort (00.0 to 99.9%)**

The rate deviation abort parameter sets the allowable percent deviation from the deposition rate. If the deposition rate deviates by more than this percentage and the deposit power is at the maximum or minimum power alert level then the process will be aborted. The default setting of 00.0% disables this function.

### **44. Sample Dwell% (000.0 to 100.0)**

The Sample Dwell% parameter establishes the percentage of the Sample Time for which the crystal is being sampled. Rate sampling is used for high deposition thickness where crystal life is a problem. By sampling the rate periodically and setting the power level to establish rate control, then closing the crystal shutter and maintaining the power level, a large deposition thickness can be achieved with one crystal. The primary sensor must have an individual shutter for the rate sample feature. The default for this parameter is 100% which enables sampling at all times.

### **45. Sample Period (0 to 9:59:59)**

The Sample Period parameter defines the sample period. For example, a sample time of 5 minutes and a dwell of 40% will result in the crystal being sampled for 2 minutes, then the crystal shutter is automatically closed for the remaining 3 minutes while the deposition power is kept constant. Please note, once the crystal shutter has opened, there is a 5-second delay for crystal stabilization before measuring.

### **46. Crystal Fail (Halt, Time Pwr, Switch)**

This parameter defines the controller's action in the event of a crystal failure. The options are to halt the process, finish the current layer on time-power, or switch to a backup crystal. Use the Enter key to cycle between the options.

### **47. Backup Sensor (1 to 4)**

This parameter defines the backup sensor input for the backup crystal. For a dual sensor head, this parameter is set to 2 assuming sensor #1 is the primary crystal. However, for six crystal sensor head, this parameter would be the same value as the Sensor# parameter and the Backup Crystal # parameter below would be set to two. This is because the six crystal sensor head uses one sensor input to measure

any of its six crystals while the dual sensor head uses two sensor inputs to measure either crystal.

**48. Tooling #2** (10.0 to 499.9%)

This parameter defines the tooling factor for the backup sensor head

**49. Backup Crystal** (1 to 8)

This parameter defines the backup crystal number.

**50. Material Password** (4 digit string) This parameter defines the edit password for the material. If the password is set to anything other than 0000 it will not be displayed, and when you attempt to edit the material you will first be asked to enter the correct password.

**4.3.3 SYSTEM SETUP**

Choosing the Edit System Setup option from the Main Menu screen will present the System Setup Menu options as shown in Figure 4-7. These options allow for setting up the controller to interface with the vacuum system and are described below.

PARAMETER/STATUS	
System Setup:	>Edit Display Setup< Program Inputs Program Outputs Program Actions Edit Sensor Setup Edit Source Setup Edit DAC Setup Edit Utility Setup

Figure 4-7 System Setup Menu screen

**4.3.3.1 EDIT DISPLAY SETUP**

Selecting Edit Display Setup will present the Display Setup screen.

PARAMETER/STATUS	
Display Setup	
Pause On Layer Complete	>Yes<
Thickness Graph Scale	3 -digit
Time To go Display	Estimated Layer
Thickness Vs. Time Graph	Disabled
Rate Vs. Time Graph	Enabled
Rate Dev. Vs. Time Graph	Enabled
Power Vs. Time Graph	Disabled ↓

Figure 4-8 Display Setup Screen

### 1. **Pause On Layer Complete** (Yes or No)

This parameter determines whether the controller will pause between layers. If this parameter is set to Yes then the controller will stop on layer complete and wait for a Start key press from the operator. If this parameter is set to No then the controller will automatically increment to the next layer.

### 2. **Thk Graph Scale** (2-digit, 3-digit)

This parameter defines whether the rightmost 2 or 3 digits of thickness will be graphed.

### 3. **Time To Go Display** (Estimated state, layer time or Elapsed process, layer or state time)

This parameter defines the displayed value of the Time To Go display on the front panel. The choices are estimated state or layer time, or the elapsed process, layer or state time.

### 4. **Thickness Vs. Time Graph** (Enabled, Disabled)

This parameter defines whether the thickness verses time graph is enabled as one of the status screens.

### 5. **Rate Vs. Time Graph** (Enabled, Disabled)

This parameter defines whether the rate verses time graph is enabled as one of the status screens.

### 6. **Rate Dev. Vs. Time Graph** (Enabled, Disabled)

This parameter defines whether the rate deviation verses time graph is enabled as one of the status screens.

### 7. **Power Vs. Time Graph** (Enabled, Disabled)

This parameter defines whether the power verses time graph is enabled as one of the status screens.

### 8. **Source/Sensor Status** (Enabled, Disabled)

This parameter defines whether the source/sensor status screen is enabled as one of the status screens.

### 9. **I/O Status** (Enabled, Disabled)

This parameter defines whether the I/O status screen is enabled as one of the status screens.

Note, if all six status screens are disabled, the **Rate Vs. Time Graph** will be displayed when the Status key is pressed.

#### 4.3.3.2 PROGRAM INPUTS

The controller has 'logical' discrete inputs which are used when running a process, and 'physical' discrete inputs at the rear-panel connector pins which can be associated arbitrarily by the user with the logical inputs using the Edit Program

Inputs function. By itself a user defined input has no effect, it can only be useful when its logical state is used as a condition for an internal action, or an external action represented by the state of a discrete output.

The controller provides for a maximum of 16 logical inputs. The 16 logical inputs can be associated with up to 8 physical inputs with the single I/O card provided with the basic controller, and with up to 16 physical inputs if the second optional I/O card is installed.

A logical input (01 to 16) can be given a 16-digit name, and can be associated with a physical input by identifying the I/O card (1 or 2) and connector pin number (30 to 37, each of which also has a separate pin for the signal return which is displayed to the right of the Pin#). The input's true level can also be defined for each input. An input defined as High true will be true when the input's voltage is at or above the high level for the particular I/O card installed.

The MDC-360 has two types of I/O cards available. The Passive I/O card, PN# 179206, has TTL level (0 to 5 volt DC) inputs. The Passive inputs are pulled up to 5 volts internally through a 4.7 K OHM resistor and are set true, assuming the input's True level is set to Low, by shorting the input pins together. The Active I/O card, PN# 179239, has 12 to 120 volt AC/DC inputs. The Active inputs are set true, assuming the input's true level is set to High, by supplying 12 to 120 volt AC or DC across the input pins. Both cards have the same relay outputs.

Use the Main Menu, Edit System Setup, Program Inputs to display the logical inputs, and the Up-arrow and Down-arrow keys to select the logical input. The Left-arrow and Right-arrow keys select the Input Name, True level, Card# and Pin# edit fields. A 16-digit name can be assigned to the logical input. Pressing the Enter key on the True level column will toggle between High or Low true. Any entry other than 1 or 2 will be ignored for the Card#, as will a Pin# less than 30 or greater than 37.

The logical discrete inputs have two categories. One category contains logical inputs that are named and assigned by the user, the other category contains logical inputs that are automatically defined by the controller, such as those required for source and sensor position feedback, and these cannot be changed by the user.

When the controller defines inputs, it selects the blank names remaining in the logical input list and assigns them in sequence to the internally generated functions. For this reason, it is important that unused inputs are left blank, and that there are sufficient inputs for all required functions.

Inputs that are internally defined are discussed further in the source/sensor setup sections. **Table 8-4** lists the input pin numbers.

PARAMETER/STATUS					
Input	Input Name	True	Card	Pin -Ret	
1	>External Start	< Low	1	30	12
2	Deposit pressure	High	1	31	13
3	Over Pressure	Low	1	32	14
4	Optical Monitor	Low	1	33	15
5		Low	1	34	16
6		Low	1	35	17
7		Low	1	36	18 ↓

**4.3.3.3 PROGRAM OUTPUTS**

The controller has ‘logical’ discrete outputs which are used when running a process, and ‘physical’ discrete outputs which can be associated arbitrarily by the user with the logical outputs using the Program Outputs function. Each physical discrete output is in the form of a pair of relay contacts assigned to dedicated pins on a controller back-panel connector, and these contacts will close when a the logical discrete output associated with the physical output satisfies a set of conditions defined by the user which are evaluated every 100 mS.

The controller provides for a maximum of 16 logical outputs. The 16 logical outputs can be associated with up to 8 physical outputs with the single I/O card provided with the basic controller, and with up to 16 physical outputs if the second optional I/O card is installed. Additionally, the controller has a relay output which is dedicated to the Abort function.

Use the Main Menu, Edit System Setup, Program Outputs to display the logical outputs, and the Up-arrow and Down-arrow keys to select the logical output.

A logical output (01 to 16) can be given a 16-digit name, and can be associated with a physical output by identifying the I/O card (1 or 2) and connector pin number (2 to 9, paired with 21 to 28, respectively, for the relay contacts).

The logical discrete outputs have two categories. One category contains logical outputs that are named and assigned by the user, the other category contains logical outputs that are automatically defined by the controller, such as those required for source and sensor rotator controls, and these cannot be changed by the user. These internally defined outputs are indicated by a condition string labeled “Internally Defined”

When the controller defines outputs, it selects the blank names remaining in the logical output list and assigns them in sequence to the internally generated functions. For this reason, it is important that unused outputs are left blank, and that there are sufficient outputs for all required functions. Outputs that are internally defined are discussed further in the source/sensor setup sections.

**Table 8-4** lists the output pin numbers.

Two screens are required to program the Discrete outputs. The first screen provides for selecting the output to be programmed, while the second screen provides for the actual programming, including the output name.

Selecting Program Outputs from the System Setup menu will present the Select Output screen.

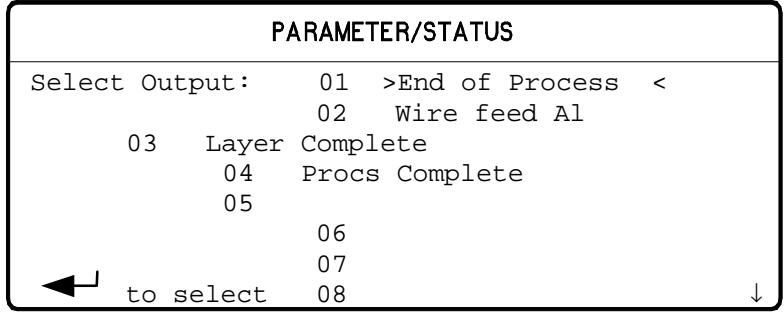

Figure 4-9 Select Output screen

Selecting an output with the Right-arrow or Enter key will present the screen which permits definition of the output, as shown below.

The Left-arrow, Right-arrow, Up-arrow and Down-arrow keys provide access to the Output Name, card#, pin# and Condition string edit fields. A 16-digit name can be assigned to the logical input. Any entry other than 1 or 2 will be ignored for the card#, as will a pin# less than 2 or greater than 9.

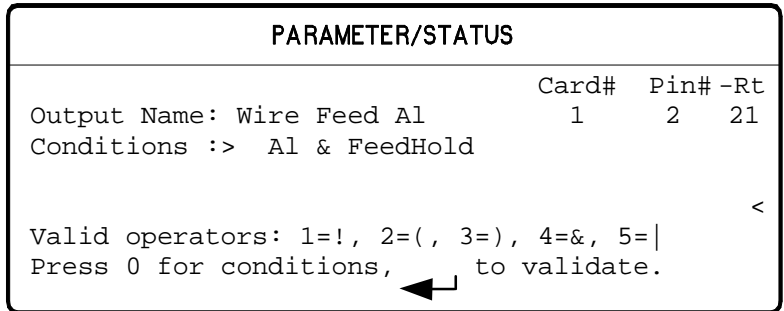

Figure 4-10 Program Output Screen

The output condition string is a logical statement that determines the state of the output. The output relay is closed when the condition string is evaluated as true. Otherwise, the relay is open. Each output condition string is evaluated ten times per second (every 100 milliseconds).

### 4.3.3.3.1 ENTERING A CONDITION STRING

A condition string comprises one or more individual conditions linked together by the logical operators ! NOT, & AND, | OR and parentheses ( ). Conditions are chosen from a list. To enter a condition string correctly you must follow these rules:

There must be an equal number of closed and open parentheses.

All conditions must be separated by either the & or the | operator.

Condition strings cannot end in an operator.

To enter a condition string, first move the markers onto the condition string field. The second line from the bottom of the screen displays the valid operators and parentheses. The screen symbols will change depending on the contents of the condition string to the left of the cursor. To select a symbol, press the corresponding key number. In the example displayed, the bottom line tells you that you press the "0" key to select a condition or, the Enter key to finish and validate the string. A blank condition string is evaluated as false.

While entering the condition string, pressing the "0" key will present a screen which has a list of condition types at the left side. For the chosen type, the right-hand side of the screen displays a list of sub-conditions or a number entry field.

Example:

If you move the marker of the left column onto the State condition type, a list of all the possible states will appear in the right column. To select one of the states, press the right arrow key to move the marker to the right column. You then move onto the desired state and press enter. This will return you to the previous screen and add the selected state to the condition string. You can return to the left column without selecting a state by pressing the Left-arrow key.

PARAMETER/STATUS			
Condition	>State	< >Process Ready	<
Type:	Event	Start Layer	
	Input	Change Pocket	
	Process	Change Crystal	
	Material	Layer Ready	
	Sensor	Soak Rise	
	Crystal	Soak Hold	
	Source	Predeposit Rise	↓

Example:

If you move the marker of the left column onto the Layer condition type, a number field will appear in the right column. To select layer #5, press the Right-arrow key to move the marker to the right column. You then type the number 5 and press Enter.

PARAMETER/STATUS	
Condition	Input
Type:	Process
	Material
Sensor	
Crystal	
	Source
	Pocket
	Layer
	Number: >005<

**4.3.3.3.2 CONDITION TYPES**

**States** - State conditions are evaluated true whenever the controller is in the respective state. Controller States are:

Process Ready

Start Layer

Change Pocket

Change Crystal

Layer Ready

Soak Rise

Soak Hold

Predeposit Rise

Predeposit Hold

Establish Rate

Deposit 1

Rate Ramp 1

Deposit 2

Rate Ramp 2

Deposit 3

Rate Ramp 3

Deposit 4

Rate Ramp 4

Deposit 5

Ramp To Feed

Feed

Ramp To Idle  
Layer Complete  
Process Complete  
Process Resume

**Events** - Event conditions are evaluated true whenever the respective event is true. Controller Events are:

Abort  
Halt  
Hold  
Time Power  
Ready  
In Process  
Simulate  
Time Setpoint  
Last Layer  
Crystal Failure  
Crystal Marginal  
Min Rate&Max Pwr  
Max Rate&Min Pwr  
Rate Dev. Alarm  
Rate Est. Error  
Source Fault  
Sensor Fault  
Rate Dev. Alert  
Max. Power Alert  
Min Power Alert  
Rate Dev. Atten.  
Max Power Atten.  
Min Power Atten.

**Inputs** - Input conditions are represented by the user defined programmable inputs. A condition is either true or false depending on the state of the input. Inputs are considered true when pulled to logic ground.

**Process** - The process condition is evaluated true whenever the selected process is the current process.

**Material** - The material condition is evaluated true whenever the selected material is the current material.

**Sensor** (1-4) - The sensor condition is evaluated true whenever the current sensor equals the specified sensor.

**Crystal** (1-8) - The crystal condition is evaluated true whenever the current crystal equals the specified crystal.

**Source** (1-4) - The source condition is evaluated true whenever the current source equals the specified source.

**Pocket** (1-8) - The pocket condition is evaluated true whenever the current pocket equals the specified pocket.

**Layer** (1-999) - The layer condition is evaluated true whenever the current layer# equals the specified layer#.

#### 4.3.3.4 PROGRAM ACTIONS

The MDC-360 provides for 16 internal user programmable actions. Internal actions are used to provide special functions at the true evaluation of a condition string. These functions may be such things as terminating a deposit on an input from an optical monitor. Or, sounding an alarm when certain events are true.

To program an action, first select the desired action from the list of 16 programmable actions displayed in the Actions screen.

PARAMETER/STATUS		
Actions:	01	Hold In State
	02	Step From State
	03	Sound Attention
	04	Sound Alert
	05	Sound Alarm
	06	> No Action <
	07	No Action
← to select action	08	No Action ↓

Once you have selected the required action, pressing the Right-arrow key will present the screen which permits programming of the action details, and this procedure is similar to the one used for programming discrete outputs.

## MDC-360 DEPOSITION CONTROLLER

---

PARAMETER/STATUS	
Action Name: >	<
Conditions :	
Valid operators: 1=!, 2=(, 3=), 4=&, 5=	
0= Add condition,	← to save

In this screen you select the predefined action you would like to take and the associated conditions. To specify an action, move the markers onto the action name field and press the Right-arrow key. This will present the Select Defined Action screen.

PARAMETER/STATUS	
Select Defined Action:	01 >No Action <
	02 Manual Power
	03 Zero Thickness
	04 Reset Controller
	05 Abort Process
	06 Halt Process
	07 TerminateDeposit
← to select	08 Hold In State ↓

In this screen you can select a predefined action from the list by moving the cursors onto the desired action and pressing Enter. The following is a list of the predefined actions:

**No Action** - No action is taken. The default setting.

**Manual** - Functionally identical to pressing Manual key.

**Zero** - Functionally identical to pressing Zero key.

**Reset** - Functionally identical to pressing Reset key.

**Abort** - Functionally identical to pressing Abort key.

**Halt** - Halts the process, sets active source power to idle, and leaves all other source powers unchanged.

**Terminate Deposit** - Triggers the final thickness for the deposit state. Action is ignored if state is not a deposit state.

**Hold In State** - Holds controller in current state.

**Step From State** - Steps controller to next state.

**Sound Attention** - Triggers the attention sound and displays the "Attention Action" message in the State/Trouble field in the Parameter/Status display.

**Sound Alert** - Triggers the Alert sound and displays the "Alert Action" message in the State/Trouble field in the Parameter/Status display.

**Sound Alarm** - Triggers the Alarm sound and displays the message "Alarm Action" in the State/Trouble field of the Parameter/Status display.

**Start Process** - Trigger the start of the currently selected process. This action is ignored unless the controller is in the Process Ready state.

**Select Process 1-8** - Select process #1-8 as the next process to be started by the Start Process action described above.

**Switch Crystals** - Toggles between the primary and the backup sensor/crystal combination defined by the active material.

Once the action is selected then you need to establish when the action should take place by defining its condition string. This is covered in the earlier section called Entering a Condition String.

**4.3.3.5 EDIT SENSOR SETUP**

Selecting Edit Sensor Setup will present the Sensor Setup screen shown in Figure 4-11. In this screen you define the sensor parameters that the controller needs to interface to the various types of sensors. Once the sensor setup is complete, the controller will create the necessary inputs and outputs needed to interface to the defined sensors. To define a sensor, first select the sensor number by using the Up-arrow and Down-arrow keys to position the cursor on the desired sensor number. Once selected, the sensor is configured by selecting the appropriate parameters from the right half of the display:

PARAMETER/STATUS		
Sensor Setup:		
	Number of Crystals	6
>Sensor #1<	Shutter Relay Type	N.O.
Sensor #2	Control	Manual
Sensor #3	Drive	Up
Sensor #4	Feedback Type	No Feedback
	Rotator Delay(sec)	00

Figure 4-11 Sensor Setup Screen

**1. Number of crystals (1 to 8)**

This parameter defines the number of crystals available for that sensor input. For a single sensor head this would be set to one. For a dual sensor head with separate oscillators and sensor connections, this would still be set to one because there is only one crystal for each sensor input. And, for a multiple rotary type

sensor head, this parameter would be set to the number of crystals that the sensor will hold.

### **2. Shutter Relay type** (N.O., N.C., None, Dual)

This parameter defines the shutter relay type used to control the sensor shutter. The following four relay types are available:

N.O. - Relay is normally open and closes to close shutter. For this type, a "SensorN Shutter" output will be created to interface to the shutter actuator.

N.C. - Relay is normally closed and opens to close shutter. For this type, a "SensorN Shutter" output will be created to interface to the shutter actuator.

None - No sensor shutter output is created.

Dual - Select this type for a dual sensor head. For this type, a "Dual Snsr1&2 Shtr" output will be created to interface to the shutter actuator.

### **3. Control** (Manual, Direct, BCD, Indiv)

This parameter defines the type of crystal position control utilized.

Manual, as it implies, means not under control of the MDC-360. Under manual control, the MDC-360 will stop the process upon the completion of the current layer when the next layer requires a different crystal position. A message prompting the operator with the number of the crystal required is displayed in the Parameter/Status window. Once the crystal has been changed, the process is resumed by pressing the Start key.

BCD and Indiv are used when control is through an external crystal rotation controller which accepts Binary Coded Decimal inputs or Individual switch closures to select the crystal. The controller creates the number of outputs required to interface with the external controller and set the outputs as required to signal a crystal

Direct is used when the actuating device is driven directly. In this case the controller creates one or two outputs, one for each available direction, to drive a motor or solenoid.

### **4. Drive** (Up, Down, Fast, Inline, Sngl Step, Dbl Step)

This parameter defines the drive method or direction for Direct control and only has an effect when Control type is set to Direct. The different settings are described below.

Up, Down, Fast and Inline - These four settings are typically used with multi-crystal heads that use a motor to rotate the crystals into position. With Up selected, the controller will create one output called "SensorN Drive Up". The 360 will activate this output to increment the sensor head up to the next position. The down selection works the same except the output is called "SensorN Drive Dn". With Fast selected, the controller will create both an up and a down output. The 360 will then determine the fastest direction to the target crystal position by activating the appropriate output. The Inline drive type informs the controller that continuous travel in one direction is not

possible. Therefore to get from position 6 to 1, the direction must be down through 5, 4, etc. until 1 is reached.

**SnglStep and Dbl Step** - Both the SnglStep and Dbl Step settings are typically used with multi-crystal sensor heads that are actuated by pulsing a pneumatic valve. The 360 will create a "SensorX Drive Up" which is either singly or doubly pulsed to sequentially step the sensor head to the next position.

**5. Feedback Type** (Individual, BCD, Single Home, In Position, No Feedback)

This parameter defines the type of feedback for a multiple sensor head. The three feedback types available are as follows:

**Individual** - Individual position feedback. This feedback type uses one input for each crystal position in the sensor head. All inputs are normally false (open circuit) unless that crystal is in position then that input is true (closed to ground). For example, a six crystal sensor head would use six inputs. If crystal two was in position then all the inputs would be false except the input connected to feedback position number two.

**BCD** - Binary Coded Decimal position feedback. This feedback type uses binary coding to indicate which crystal is in position. Inputs are numbered most significant bit first. For example, an eight crystal sensor head would use three inputs. With crystal one in position, all inputs would be false. With crystal four in position, inputs one and two would be true and input three would be false.

Table of Input states for BCD feedback type.

Crystal number	Input BCD2	Input BCD1	Input BCD0
1	OPEN	OPEN	OPEN
2	OPEN	OPEN	GND
3	OPEN	GND	OPEN
4	OPEN	GND	GND
5	GND	OPEN	OPEN
6	GND	OPEN	GND
7	GND	GND	OPEN
8	GND	GND	GND

**SNGL HOME** - Single home position feedback. This feedback type uses one input. The input is normally false (open circuit) and should go true (closed to ground) when crystal one is in position.

**IN POSITION** - In position feedback. This feedback type uses one input. The input is normally false (open circuit) and should go true (closed to ground) when the desired crystal is in position.

## MDC-360 DEPOSITION CONTROLLER

---

NO FEEDBACK - No crystal position feedback is used.

### 6. Rotator Delay (0 to 99 seconds)

This parameter serves two different functions. If the feedback type is “None” (Not recommended. See cautions in the Installation section.) this parameter tells the controller how long to wait assuming the crystal is in position. If position feedback is provided, this parameter tells the controller how long it should wait for the crystal to reach its target position before it issues a Sensor Fault message.

#### 4.3.3.6 EDIT SOURCE SETUP

Selecting Edit Source Setup will present the Source Setup screen as shown in Figure 4-12. In this screen you first select the source setup you wish to edit. To select a source, use the Up-arrow and Down-arrow keys, then press the Right-arrow or Enter key to select.

PARAMETER/STATUS		
Source Setup:	Number of Pockets	6
	Shutter Relay Type	N.O.
>Source #1<	Shutter Delay (sec)	0.0
Source #2	Control	Direct
Source #3	Drive	Up
Source #4	Feedback Type	Indv Pos
	Pocket Delay (sec)	10
	Source Voltage	10V

Figure 4-12 Source Setup screen

Once selected, the source is configured with the following parameters located on the right side of the display:

#### 1. Number of Pockets (1 to 8)

This parameter defines the number of pockets, or crucibles, available for the source. The default value is 1 for a single pocket source.

#### 2. Shutter Relay type (N.O., N.C., None)

This parameter defines the shutter relay type used to control the source shutter. The following three relay types are available:

N.O. - Relay is normally open and closes to close shutter. For this type, a “SourceN Shutter” output will be created to interface to the shutter actuator.

N.C. - Relay is normally closed and opens to close shutter. For this type, a “SourceN Shutter” output will be created to interface to the shutter actuator.

None - No sensor shutter output is created.

#### 3. Shutter Delay (sec) (0.0 to 9.9 seconds)

This parameter defines the amount of time allowed for the source shutter to close.

### 4. Control (Manual, Direct, BCD, Indv)

This parameter defines the type of pocket control utilized.

Manual, as it implies, means not under control of the MDC-360. Under manual control, the MDC-360 will stop the process upon the completion of the current layer when the next layer requires a different pocket. A message prompting the operator with the material required is displayed in the Parameter/Status window. Once the pocket has been changed, the process is resumed by pressing the Start key.

BCD and Indv are used when control is through an external pocket rotation controller which accepts Binary Coded Decimal inputs or Individual switch closures to select the pocket. The controller creates the number of outputs required to interface with the external controller and sets the outputs as required to signal a pocket change.

Direct is used when the actuating device is driven directly. In this case the controller sets up one or two outputs, one for each available direction, to drive a motor or solenoid.

### 5. Drive (Up, Down, Fast, Inline, Sngl Step, Dbl Step)

When the Control type is Direct, this parameter defines the drive method or direction. For Sngl Step and Dbl Step drive types, the controller sets up one output which is either singly or doubly pulsed to actuate a solenoid to sequentially step the rotator to the desired position. For Up and Down drive types, the controller sets up one output to control a drive motor which is turned on until the rotator reaches the desired position. For Fast and Inline drive types, the controller sets up a drive up and a drive down output. For the Fast drive type, the controller determines the fastest direction to the target pocket position and turns on the appropriate output. The Inline drive type, informs the controller that continuous travel in one direction is not possible. Therefore to get from position 6 to 1, the direction must be down through 5, 4, etc. until 1 is reached.

The controller creates one or more of the following outputs depending on the type:

Drive Up

Drive Down

Step

### 6. Feedback Type (Individual, BCD, Single Home, In Position, No Feedback)

This parameter defines the type of feedback for a multiple pocket source. The three feedback types available are as follows:

Individual - Individual position feedback. This feedback type uses one input for each pocket position in the source. All inputs are normally false (open circuit) unless the respective pocket is in position then that input is true (closed to ground). For example, a six pocket source would use six inputs. If pocket two was in position then all the inputs would be false except the input connected to feedback position number two.

---

## MDC-360 DEPOSITION CONTROLLER

---

**BCD** - Binary Coded Decimal position feedback. This feedback type uses binary coding to indicate the pocket position. Inputs are numbered most significant bit first. For example, an eight pocket source would use three inputs. With pocket one in position, all inputs would be false. With pocket four in position, inputs one and two would be true and input three would be false.

**SNGL HOME** - Single home position feedback. This feedback type uses one input. The input is normally false (open circuit) and should go true (closed to ground) when pocket one is in position.

**IN POSITION** - In position feedback. This feedback type uses one input. The input is normally false (open circuit) and should go true (closed to ground) when the desired pocket is in position.

**NO FEEDBACK** - No pocket position feedback is used.

Table of Input states for BCD feedback type.

Pocket Number	Input BCD2	Input BCD1	Input BCD0
1	OPEN	OPEN	OPEN
2	OPEN	OPEN	GND
3	OPEN	GND	OPEN
4	OPEN	GND	GND
5	GND	OPEN	OPEN
6	GND	OPEN	GND
7	GND	GND	OPEN
8	GND	GND	GND

### 7. Rotator Delay (0 to 99 seconds)

This parameter serves two different functions. If the feedback type is “None” (Not recommended. See cautions in the Installation section.) this parameter tells the controller how long to wait, on the assumption the pocket will get into position. If position feedback is provided, this parameter tells the controller how long it should wait for the pocket to reach its target position before it issues a Source Fault message.

### 8. Source Voltage (2.5V, 5.0V, 10V)

This parameter sets the upper voltage range for the source control output. The lower voltage range is always 0. For example, selecting 10 for this parameter sets the source control voltage range from 0 to 10 volts.

**4.3.3.7 EDIT DAC SETUP**

Selecting Edit DAC Setup from the Edit System Setup menu will present the DAC Setup screen which allows selection of the parameter and its signal range for each of the two DACs.

PARAMETER/STATUS			
DAC Setup			
DAC Output	#1	>Rate	<
DAC Scale	#1	2 Digit	
DAC Output	#2	Power	
DAC Scale	#2	2 Digit	

Figure 4-13 DAC Setup Screen

**1. DAC Output (Rate, Rate Dev., Power, Thickness)**

One of four system control parameters is chosen for the DAC output. The default setting is Rate for DAC #1 and Rate Deviation for DAC #2.

**2. DAC Scale (2-digit, 3-digit)**

Either the two least significant, or the three least significant, digits of the chosen control parameter are used to represent full scale for the DAC output.

**4.3.3.8 EDIT UTILITY SETUP**

Selecting the Edit Utility Setup from the Edit System Setup menu will present the Utility Setup screen. Figure 4-14 shows the first page of this screen. All parameters are described below.

PARAMETER/STATUS	
Utility Setup	
Crystal Freq.	6.0 MHz
Simulate mode	On
Interface address	01 (1-32)
Attention Volume	01 (0-10)
Alert Volume	01 (0-10)
Alarm Volume	01 (0-10)
Data Points/min	60 ppm

Figure 4-14 Utility Setup screen

**1. Xtal Freq. (2.5, 3.0, 5.0, 6.0, 9.0, 10.0 MHz)**

This parameter determines the uncoated crystal frequency type for all sensor inputs. The default setting is 6.0 MHz.

### **2. Simulate Mode (On, Off)**

This parameter enables or disables the Simulate mode of the controller. The Simulate mode is used for process testing and differs from the Normal mode only to the extent that the Thickness and Rate displays are derived from a simulated sensor input rather than the actual sensor. While in this mode, the simulated thickness build-up is directly proportional to the displayed power level and independent of actual thickness on the sensor. The Simulate mode allows the total deposit process to be simulated. It also allows the tooling factor, density and acoustic impedance calculations to be conveniently checked and altered at the end of the run, if necessary.

### **3. Interface Address. (1-32)**

This parameter sets the controller's computer interface address for the RS-485 and IEEE-488 interfaces.

### **4. Attention Volume (0-10)**

This parameter sets the volume of audio attention sound. Attention sounds indicate that the controller is waiting for an operator response or action before continuing the process. A setting of zero disables audio attention sound.

### **5. Alert Volume (0-10)**

This parameter sets the volume of audio alert sound. Alert sounds indicate that a material alert level has been exceeded. A setting of zero disables audio alert sounds.

### **6. Alarm Volume (0-10)**

This parameter sets the volume of audio alarm sound. Alarm sounds indicate that a material alarm level has been exceeded. A setting of zero disables audio alarm sounds.

### **7. Data Points/Min (30,60,120,300,600 PPM)**

This parameter sets the number of run-time data point sets per minute that will be written to the process log. The default is 600 data points/minute. During a process, data is logged automatically up to 10 data point sets per minute. At this rate the 27,000 data point storage can hold 45 minutes of data. To allow for longer processes, you can change the number of data point sets stored per minute. The following table shows the approximate storage time based on the number of data points per minute parameter. Press the 'Enter' key to cycle between options. This parameter is only visible when the data logging option is installed.

<b>Data Points/Minute</b>	<b>Aprox. Storage Time (minutes)</b>
30	900
60	450
120	225
300	90
600	45

**8. Time** (00:00-23:59)

This parameter sets the system time. Time is entered in 24-hour format without a digit separator “:”. For example, to enter 1:05 PM you must enter “1305”. This parameter is only visible when the data logging option is installed.

**9. Date** (01/01/00-12/31/99)

This parameter sets the system date in month/day/year format. The complete date must be entered without the digit separator “/” character, and with two digits for each of the month, day and year. For example, to enter 5/2/94, you must enter “050294”. This parameter is only visible when the data logging option is installed.



## 5. OPERATING THE MDC-360

### 5.1 SIGN-ON SCREEN

At power-on the Parameter/Status display will present a screen which details the controller configuration, and all LEDs will be illuminated. The figure below shows the configuration for a basic MDC-360 with a single Source/Sensor card, a single Discrete I/O card and an RS-232 interface installed. Please refer to Sections 2, 3 and 4 for a detailed description of the MDC-360 resources and how to use them before attempting to operate the controller.

At this point, with the sign-on configuration information on the LCD screen and all LED's illuminated, pressing any key momentarily will put the controller into the Abort mode. Within the illuminated key pad group, only the red LED behind the Abort key pad will now be illuminated. Each digit position of the process-run numerical LEDs will contain a 0-9 value. The information displayed by the LCD screen will depend on what was being displayed when power to the controller was last turned off.

Press the Reset key to put the controller into the Reset state in preparation for a process-run.

PARAMETER/STATUS		
Maxtek MDC-360 Software Version x.x		
Source/Sensors Cards	1	Installed
Discrete I/O Cards	1	Installed
RS-232 Computer Interface		Installed
Data Log Storage		Not Installed
Press any key to continue.		

Figure 5-1 Sign-on screen

### 5.2 STARTING A NEW PROCESS

Pressing the Start key while the controller is in the Ready state will present the screen shown below. A run number is provided to help correlate process information with a specific process run. The run number can range from 1 to 9999. It is incremented at the start of each process. At 10,000 the run number will roll over to 1.

PARAMETER/STATUS			
Start Process:	01	>Sample	<
	02		
Starting Layer: 001	03		
Run Number : 0001	04		
	05		
	06		
Press Start to start	07		
or Reset to cancel.	08		

Figure 5-2 Run Process Selection Screen

From this screen you can change the starting layer number and run number, if required, using the arrow keys to position the edit cursors, and can then select the process to start by positioning the cursors on the desired process name, which then becomes the 'current' process. To actually start the process just press the Start key again. The controller will then scan the total process definition and the condition of the system, and if everything appears to be in order will start the process.

If at this point an error message is presented by the LCD screen, it is likely that there is a problem somewhere with either the system configuration and/or the value of a system parameter which will prevent the process from running correctly. Use the details of the error message as an indication of the corrective action that should be taken. Press the Abort key to abort the process start, then the Reset key, and then make the necessary changes.

### 5.3 STARTING A NEW LAYER

The Start key is also used to start individual layers when the controller is set up for manual layer sequencing. The controller will prompt the operator to press the Start key to start the next layer.

### 5.4 RESUMING AN ABORTED OR HALTED PROCESS

The Start key is also used to resume an aborted or halted process. Pressing the Start key while the controller is in abort or halt mode will bring up the following prompt. Note that the green LED behind the Start key is illuminated, indicating that the process is resumable. Otherwise, the controller has to be reset, and the process has to be started over.

Press Start to resume process or Reset to cancel.
--

Follow the prompt to resume the process.

### 5.5 STATUS DISPLAYS

There are six different run time status screens that can be displayed at any time by pressing the Status key (providing they have each been enabled using Edit Display Setup). The first key press will bring up the last viewed status screen, repeatedly pressing the Status key will cycle through the six status screens, shown below.

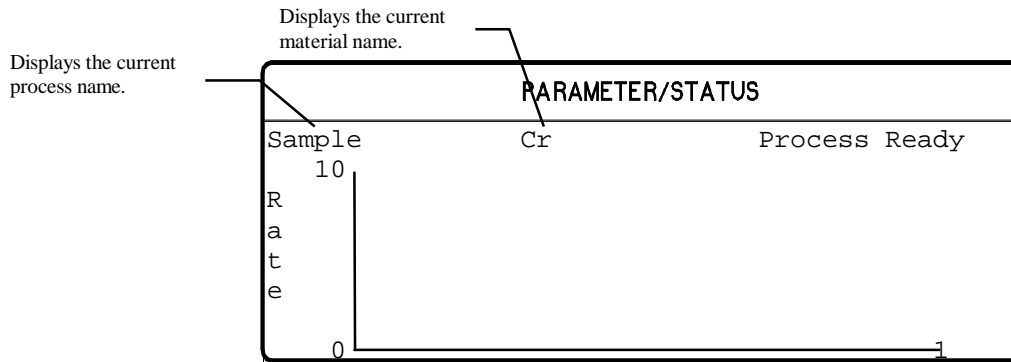

Figure 5-3 Rate vs. Time Graph

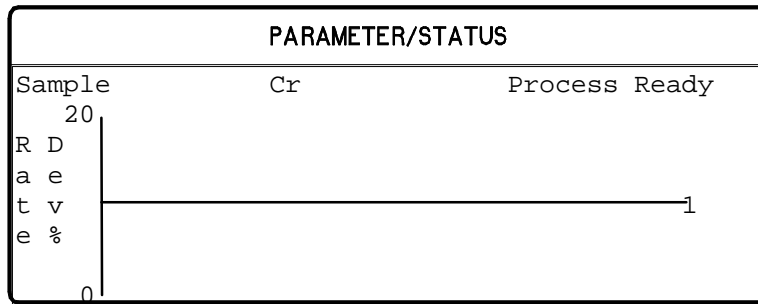

Figure 5-4 Rate Deviation vs. Time graph

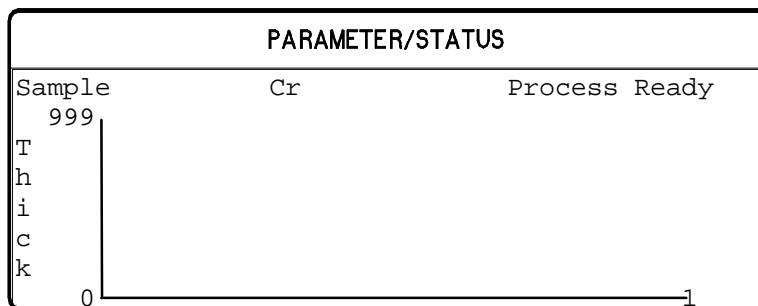

Figure 5-5 Thickness vs. Time Graph

# MDC-360 DEPOSITION CONTROLLER

---

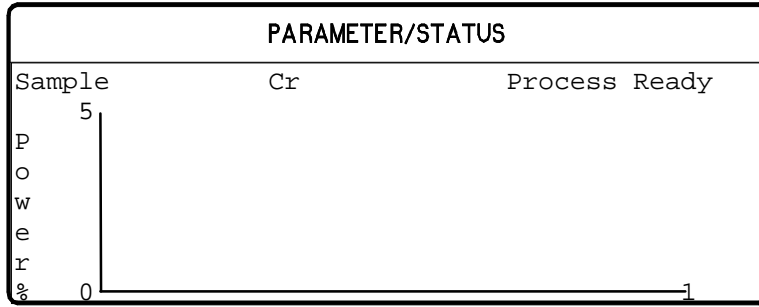

Figure 5-6 Power vs. Time Graph

PARAMETER/STATUS					
Sample	Cr	Process Ready			
Source Status			Sensor Status		
Src#	Pckt#	Power	Snsr#	Xtl#	Health
1	1	23.7	1	1	95
2	1	10.0	2	1	99
3	1	10.0	3	1	99
4	1	10.0	4	1	99

Figure 5-7 Source/Sensor Status screen

PARAMETER/STATUS				
Sample	Cr	Process	Ready	
Input	State	Output	State	
01>Name	F		F<	
02	F		F	
03	F		F	
04	F		F	
05	F		F	
06	F		F	

Figure 5-8 I/O Status Screen

## 5.6 VIEWING RESULTS

The MDC-360 has an optional Internal Data Storage capability that provides internal storage of real time run data. Stored data can later be viewed through the four status graphs or can be downloaded to a PC for permanent storage and/or review.

## MDC-360 DEPOSITION CONTROLLER

---

The data log option provides storage for up to 16 process logs and/or 27,000 data point sets of real time run data. A process log consists of the process name, run number, starting time and date, ending time and the completion status of the run. The process logs are stored in a stack such that newest process is at the top of the stack and the oldest process is at the bottom of the stack. The start of the next process will push all of the logs down one position on the stack. The last or 16th process log on the stack will be lost.

A data point set consists of the measured deposit rate, rate deviation, thickness and the deposit power. The 27,000 data point sets are stored in a circular buffer such that new data will overwrite the oldest data. If data from the current process overwrites an older process than that entire process will be erased. If data from the current process tries to overwrite the start of the current process then data logging is stopped so that the beginning of the process is saved.

During a process, data is logged automatically up to 10 data point sets per minute. At this rate the 27,000 data point storage can hold 45 minutes of data. To allow for longer processes, the user has the ability to change the number of data point sets stored per minute. The parameter to modify is called Data Points/Min and can be found in the Utility Setup menu. The following table shows the total storage time based on the number of data points per minute parameter.

<b>Data Points/Minute</b>	<b>Aprox. Storage Time (minutes)</b>
30	900
60	450
120	225
300	90
600	45

To view a stored process log select the View Results option from the Main Menu. This will present a screen with the process log shown in Figure 5-9. From this screen any of the 16 process logs can be selected for viewing. Note that this screen is only available if the Internal Data Storage and Time/Date Clock option installed.

## MDC-360 DEPOSITION CONTROLLER

PARAMETER/STATUS				
Process Name	Run#	Time	Date	Status
>Sample	0002	12:05	12/28/94	Normal <
Sample	0001	09:54	01/23/95	Aborted

Figure 5-9 View Results Screen

This screen displays the process name, run number, starting time and date and the status. The status can be either running, normal, aborted or overrun. Overrun means that this process overran itself within the data store.

To select a process log for viewing, just move the cursors onto the desired process and press the Enter or the Right-arrow key. Please note that you cannot view a process log while in-process.

Once a process has been selected, the screen will change to the rate vs. time graph shown in Figure 5-10. The logged data will be plotted for the first layer of the process. Plotting the data may take from 5 seconds for short layer to up to 15 seconds or more for long layers with a lot of data. Please note that while the data is being plotted the controller will not read any key presses. When the data has been plotted the layer number will be displayed in the upper right hand corner of the screen. At this point you can press the Status key to switch between the four graphs. You can also enter a different layer number to view another layer.

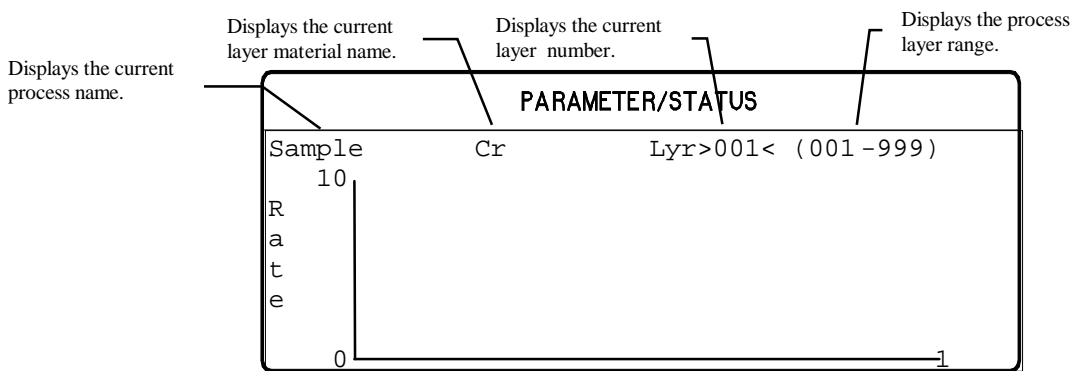

Figure 5-10 Rate vs. Time Process Log Graph

To return to the process log, press the Left-arrow key.

### 5.7 MODES

Modes are conditions which the controller can occupy. Some modes are indicated by the LED's behind the operating keys. Other modes are displayed in the top right hand corner of the status display (Refer to Figure 5-3). These controller modes are described below.

#### 5.7.1 PROCESS READY

The Process Ready Mode indicates the MDC-360 has been reset and is awaiting a Start key press. The yellow LED behind the Reset key, when illuminated, indicates that the controller is in Process Ready Mode.

#### 5.7.2 ABORT

The Abort mode is indicated by a red LED behind the Abort key as well as the flashing of all of the numeric LED displays. In Abort Mode all displays and operating keys, with the exception of the Start and Reset keys, are inoperative. All source control outputs are forced to zero, the Abort relay is closed and all discrete outputs are forced to open circuit. In addition, if the controller initiated the abort then the condition which caused the abort will be displayed in the top right hand corner of the Parameter/Status display. Exit from Abort Mode requires either a Reset or Start key press. See also Section 5.4 for resuming an aborted process. Refer to Table 5-1 for condition which causes an abort.

#### 5.7.3 HALT (SOFT ABORT)

In Halt all I/O is frozen. If power is above Soak level, it is ramped down to Soak at the Predeposit ramp rate. If Power is at or below the Soak level it is held constant. The user has the option to resume from Halt or press Reset and start over. See also Section 5.4 for resuming a halted process. Refer to Table 5-1 for conditions which cause the process to halt.

#### 5.7.4 IN PROCESS

The green LED behind the Start key, when illuminated, indicates the controller is in the In-Process Mode.

#### 5.7.5 NOT SAMPLING

This mode indicates that the sensor crystal is shuttered from the source and that the deposition rate is established using the last power level. Sampling mode is set by two material parameters, Sample Dwell % and Sample Period. Refer to Section 4.3.2.1 # 44 and # 45 for a description of Sample Mode.

#### 5.7.6 PROCESS COMPLETE

This mode indicates that the selected process has run to completion. A Process Complete message is displayed in the top right hand corner of the status display. In addition, an attention warning will sound. The controller remains in this mode until a reset signal puts it into the Process Ready mode.

**5.7.7 MANUAL**

This mode is indicated by the red LED behind the Manual key. In this mode the control voltage output is controlled through the Remote Power Handset. For a detailed description of this mode, refer to Section 3.5.

**5.7.8 SIMULATE**

This mode simulates rate and thickness build-up by simulating the sensor input rather than the actual sensor. Refer to Section 3.4 for more information on the Simulate Mode.

**5.8 STATES**

Figure 5-11 shows the different states that make up a complete deposition cycle, such as Rise to Soak, Rise to Predeposit, etc. The controller moves from state to state as the deposition progresses.

**5.9 TROUBLE, ERROR AND WARNING MESSAGES**

Troubles are controller conditions which in most case are indicative of problems or errors, but may be just warnings. These messages are displayed in the top right hand corner of the status screen (See Figure 5-3).

In addition, there are three levels of audible warnings associated with the trouble conditions, Attention, Alert and Alarm. Table 5-1 lists the messages and warning levels. The list is arranged in descending order of priority. In the event that more than one warning level is triggered, the higher level has priority. An asterisk in the Clear column indicates the warning sound will clear when the condition clears. Any key press will also clear the sound. The action column indicates what if any action is taken as a result of the trouble.

Messages	Warning		
	Type	Clear	Action
Min Rate&Max Power	Alarm		Abort
Max Rate&Min Power	Alarm		Abort
System Setup memory corrupted	Alarm		Halt
Process memory corrupted	Alarm		Halt
Material memory corrupted	Alarm		Halt
Rate Est. Error	Alarm		Halt
Crystal Failure	Alarm/Attn	NO/*	Halt
Source Fault	Alarm		Halt
Sensor Fault	Alarm		Halt
Time Power	Alarm		Time/Power
Rate Dev. Alarm	Alarm	*	
Alarm Action	Alarm		
Crystal Marginal	Alert/Attn	NO/*	
Rate Dev. Alert	Alert	*	
Max power Alert	Alert	*	
Min power Alert	Alert	*	

## MDC-360 DEPOSITION CONTROLLER

Alert Action	Alert	*	
Xtal Fail Switch	Attention		Crystal Switch
Xtal Mrgn Switch	Attention		Crystal Switch
Rate Dev. Atten	Attention	*	
Max power	Attention	*	
Min power	Attention	*	
Change source # X to (material name) and press Start to continue.	Attention		Hold
Change sensor # X to crystal # X and press Start to continue.	Attention		Hold
Attention Action	Attention	*	
Press Start to resume process.	N/A		
Start to continue.	Attention	*	Hold

Table 5-1 Trouble Conditions and Warnings

### 5.9.1 DESCRIPTION

Each of the messages is described below.

#### 5.9.1.1 MIN RATE&MAX POWER

This message indicates that the output power is at the maximum power level set by the Maximum Power parameter and the rate deviation is below the limit value set in the Rate Dev. Alarm parameter. When this happens, the controller will go into the Abort mode and the Alarm will sound.

#### 5.9.1.2 MAX RATE&MIN POWER

This message indicates that the output power is at the minimum power level set by the Minimum Power parameter, and the rate deviation is above the limit value set by the Rate Dev. Abort parameter. When this happens, the controller will go in Abort mode and the Alarm warning will sound.

#### 5.9.1.3 SYSTEM SETUP MEMORY CORRUPTED

The integrity of the System Setup Memory has changed since the last time a system parameter was modified. Each one of the sub menus and its parameters has to be checked and corrected as necessary to fix this problem.

#### 5.9.1.4 PROCESS MEMORY CORRUPTED

The integrity of the selected process has been changed since last time the process was modified. Each one of the process parameters has to be checked and corrected as necessary to fix this problem.

### **5.9.1.5 MATERIAL MEMORY CORRUPTED**

The integrity of the selected material has been changed since last time the material was modified. Each one of the material parameters has to be checked and corrected as necessary to fix this problem.

### **5.9.1.6 RATE EST. ERROR**

The controller is unable to establish the programmed rate within the time specified in the Rate Establish Time parameter. The rate is considered established when it stays within the Rate Establish Error % for 5 seconds.

### **5.9.1.7 CRYSTAL FAILURE**

This condition indicates lack of a valid signal from the sensor, and generally results from a failed crystal but may also indicate problems in the crystal mounting or the interconnection between the sensor and the controller. If the primary crystal fails and the process is not in deposit state, the Attention warning will sound. If the backup crystal fails and the process is not in the deposit state, the alarm will sound and the process will be halted.

### **5.9.1.8 SOURCE FAULT**

This condition indicates that the correct source pocket position feedback has not been achieved within the time set by the Rotator Delay parameter (Source Setup Menu).

### **5.9.1.9 SENSOR FAULT**

This condition indicates that the correct crystal position feedback has not been achieved within the time set by the Rotator Delay parameter (Sensor Setup Menu).

### **5.9.1.10 TIME POWER**

This message is displayed when the controller is completing the current layer based on the last power and rate. This occurs in the event of a crystal failure without a backup.

### **5.9.1.11 RATE DEV. ALARM**

The deposition rate error is greater than the rate deviation value set in the Rate Deviation Alarm parameter.

### **5.9.1.12 ALARM ACTION**

This message indicates the Alarm sound was initiated by an internal action.

### **5.9.1.13 CRYSTAL MARGINAL**

The sensor crystal in use is poor in quality. If the crystal is the backup one, the Alert warning will sound when the process is in deposit state. If the primary crystal is in poor quality then the Attention will sound.

### **5.9.1.14 RATE DEV. ALERT**

The deposition rate deviation is greater than the value set in the Rate Deviation Alert parameter.

### **5.9.1.15 MAX POWER ALERT**

Indicates that the power output level has been at the Maximum Power level longer than the time period set in the Power Alert Delay parameter.

### **5.9.1.16 MIN POWER ALERT**

Indicates that the power output level has been at or below the Minimum Power level longer than the time period set in the Power Alert Delay parameter.

### **5.9.1.17 ALERT ACTION**

This message indicates the Alert sound was initiated by an internal action.

### **5.9.1.18 XTAL FAIL SWITCH**

This message indicates the primary crystal has failed and the sensor input has been switched to the backup crystal. In addition, the Attention warning sounds. Press any key to clear the sound.

### **5.9.1.19 XTAL MRGN SWITCH**

This message indicates the primary crystal is marginal and the sensor input has been switched to the backup crystal. In addition, the Attention warning sounds. Press any key to clear the sound.

### **5.9.1.20 RATE DEV. ATTEN**

The deposition rate deviation error is greater than the value set in the Rate Deviation Attention parameter.

### **5.9.1.21 MAXIMUM POWER**

The output power is being limited by the value set in the Maximum Power parameter.

### **5.9.1.22 MINIMUM POWER**

The output power is at or below the minimum power set by the Minimum Power parameter.

### **5.9.1.23 CHANGE POCKET...**

Prompts the operator to switch the source pocket to the correct position. The process will be on hold until the Start key is pressed. There is no message if the Control parameter is set to Auto (Source Setup Menu).

### **5.9.1.24 CHANGE CRYSTAL...**

Prompts the operator to switch the sensor to the correct crystal position. The process will be on hold until the Start key is pressed. There is no message if the Control parameter is set to Auto (Sensor Setup Menu).

### **5.9.1.25 ATTENTION ACTION**

This message indicates the Alert sound was initiated by an internal action.

# MDC-360 DEPOSITION CONTROLLER

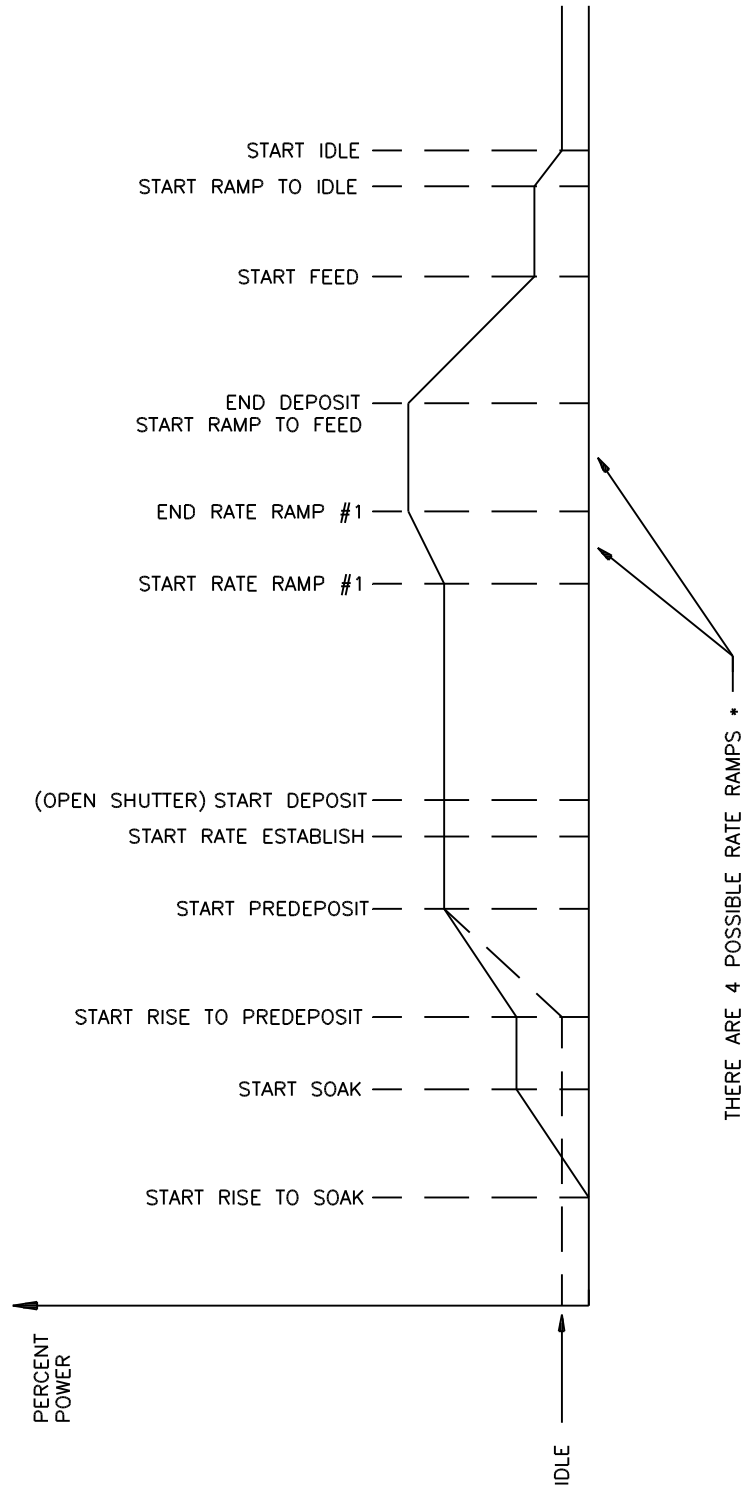

Figure 5-11 Typical Process Profile



## 6. TUNING THE MDC-360 CONTROL LOOP

### 6.1 Control Loop Basics

If evaporation rate were a function of source power alone, a rate controller would not be necessary. One would establish the power required to achieve the desired rate, set the power at that point and that would be that. In control system parlance, this is called “Open Loop” control.

Unfortunately, evaporation rate is a function of many variables. With E-gun sources, rate is affected by material level, water cooling temperature, beam position, sweep pattern, etc. With filaments and boats, rate is affected by material level, boat or filament condition, power line voltage, power losses in cables, connections, transformers, switches, etc. Even when sputtering under the conditions of constant power and constant pressure, rate is affected by target condition.

So, if we want to achieve a known and constant rate, we need a rate controller. The rate controller compares the measured rate with the desired rate and attempts to keep them equal by adjusting the command signal to the power supply. This is called “Closed Loop” or feedback control.

The most common example of feedback control is a car and driver. The car is the “Plant”. It is controlled by pedal pressure and steering wheel angle. Its output is direction and speed. The driver is the “Controller”. The driver monitors the direction and speed and adjusts pedal pressure and steering wheel angle to achieve the direction and speed he/she desires. If we hold the controls steady and close our eyes, no feedback, then our control is open loop. If the road is very straight and there is no wind, “no disturbances to the plant”, we can sometimes stay on the road for a pretty good distance. If the road is rolling or we have a good crosswind, the time we can stay on the road in open loop control can be pretty short indeed.

If the controller is slow and sluggish, i.e. a drunk driver, the difference between the desired speed and direction can be very different from the speed and direction desired. The driver can be all over the road, speeding up, slowing down, etc.

If the controller's gain is too high, typical of a young person's first driving experience, the response to an error is both slow and too great and the car careens from one side of the road to the other. This control “System” would normally go completely unstable and crash if control were not assumed by a different controller.

In the case of a young driver with a little more experience under his/her belt, the response speed has improved but the gain is still a little high. The vehicle stays pretty well in control but there is a lot of steering wheel action. We say this controller is “oversteering”.

When we go from one vehicle to another, especially if the vehicles are very different in size or weight, we find that we must really concentrate on our driving at first. That is because we are learning the characteristics of the “Plant”. As

soon as we've learned them, we know what we have to do to correct for errors and we are back in good control. In other words the controller must compensate for the characteristics or the "Plant".

### 6.2 CONTROL LOOPS APPLIED TO VACUUM DEPOSITION

In the deposition control loop the vacuum system and evaporation supply make up the plant. The output, deposition rate, is controlled by the source control voltage which establishes the source power. If all plants were the same we could predefine the characteristics of the controller for optimum control. Unfortunately, plants vary widely, in their gain, linearity, response, noise and drift.

The question we are going to address here is how the controller adjusts the source control voltage, the "command signal". The MDC utilizes a type 1 control loop. A type 1 control loop does not require a continuous error to achieve a non zero control voltage.

Many controllers utilize a type 0 control loop. In this type of loop the source control voltage output is determined by multiplying the rate error by the Proportional gain. For any given non zero output the error required to achieve the necessary output is inversely proportional to the gain. High gain, low error, low gain, high error. This would seem to call for high gain. Unfortunately, the higher the gain the higher the chance of instability. We may go unstable before we get the error down to where we want it.

In the MDC, the proportional gain parameter sets the rate at which the control voltage changes in response to an error signal. Any error in the rate causes the source control voltage to ramp to a new value. When the source control voltage increases or decreases to the correct value, the value required to achieve the desired rate, the error goes to zero and the output remains constant.

The Derivative Time constant is utilized to compensate for slow sources such as boats and induction heated sources. Like a large truck, these sources take time to get up to speed and to stop. The Derivative Time constant looks at the rate of change of the error. If the error is decreasing rapidly we better take our foot off the gas or we are going to overshoot our target. If the error is decreasing, but decreasing very slowly, we need to goose it to get up to speed. The Derivative Time constant instructs the controller on how much attention to pay to the rate of change of the error. A value of zero tells the controller to ignore the rate of change of the error. A large value tells the controller that this source is slow and is going to be hard to get going and hard to stop. So if the rate starts to fall off, give it power, or if we're quickly approaching the target, begin to decrease the power.

The Integral Time constant is used to keep the thickness profile on schedule. We may have no rate error right now, so if we were not concerned about the thickness profile, we would be happy and leave everything as it is. However if we are trying to stay on a thickness profile, stay on schedule as it were, we may want to speed up or slow down a little bit to make up for previously lost, or gained time. For example, suppose our desired speed is 50 mph and that's the speed we are traveling. However we've been traveling for exactly an hour and we've only

gone 48 miles because of some traffic earlier on. Our Integral error is 2 miles. If we want to get back on schedule we need to speed up a bit. If schedule is very important to us, we will speed up a lot to get back on schedule fast. If schedule is not important at all we will maintain our speed. The Integral Time constant instructs the controller on how much attention to pay to the schedule. If we don't care what happened in the past and we want zero rate error right now, we don't want any Integral feedback. To accomplish that we set the Integral Time constant to its maximum value, which tells the controller to ignore any past error unless it lasts for a very long.

### 6.3 ESTABLISHING MDC-360 CONTROL LOOP PARAMETERS

As explained above, the MDC utilizes three control loop parameters referred to as PID parameters; Proportional gain, Integral Time constant and Derivative Time constant to provide for optimization of the control loop. The MDC provides default values for each of these parameters.

Default and Range for PID Parameters

Parameter	Minimum value	Maximum value	Default value
Proportional gain	1	9999	1000
Integral time constant, sec.	0	99.9	99.9
Derivative time constant sec.	0	99.9	0.0

## MDC-360 DEPOSITION CONTROLLER

---

The following table lists some recommended PID values for different types of deposition sources. These values represent a good starting point and in some cases may not need to be further modified.

Suggested PID Starting Values for Different Sources

Parameter	Electron Beam Gun	Filament Boat
Proportional gain	2000	600
Integral time constant, sec.	99.9	99.9
Derivative time constant sec.	25.0	75.0

In the MDC-360, the PID parameters are defined at the material level because different materials often require different PID settings even though they may be deposited from the same source. Therefore it is usually necessary to establish the PID parameters for every each material and deposition source.

The first step in setting the PID parameters for a new material or source is to enter the recommended starting values listed above. Be sure and choose the PID values for the type of source you're using. Next, create a dummy process with the first layer set for the new material. Start and abort the dummy process to load the new material as the active material. You should now see the material's name in the top line of any Status Screen. Next, open the shutter and put the 360 in the manual power mode and adjust the source power using the remote handset to establish the power ramp parameters. Set the Predeposit Power level at or slightly below the power needed to get the desired deposition rate.

With the power ramp parameters defined, the next step is to start the dummy process to see how well the 360 controls the rate. If the rate is too high or low when the shutter opens then make a note to go back and adjust the Predeposit Power level. Watch the rate graph and the power display. If the rate is different from the target rate then you should see the 360 adjust the power attempting to achieve the target rate. If the rate is close to the target, then you should temporarily change the rate to see how the 360 reacts. Ideally the 360 will adjust the power so that the rate goes right to the target rate without overshooting it. If it does then no further adjustments are necessary.

If it seems like the 360 is reacting too slowly, press the Program key to get back to the material screen and increase the Proportional Gain parameter. Begin with changes of about 10 to 20%. Changes of this magnitude are a good starting point because they are large enough to show the effect of the parameter and small enough that you won't greatly overshoot the ideal setting. Remember that too much Proportional Gain will make the system unstable and too little will make the 360 slow to react. An unstable system is evident by the rate oscillating around the target value. A general rule of thumb is the faster the source, the larger the Proportional Gain. And conversely, the slower the source the smaller the Proportional Gain.

With the Proportional Gain at an acceptable value, the next step is to adjust the Derivative Time if necessary. Disturb the system again by changing the target rate. Watch the rate graph as the rate approaches the target. If the rate overshoots the target then increase the Derivative Time and change the target rate again to see the effect. Repeat these steps slowly increasing the Derivative Time until the rate goes right to the target without overshoot.

In very slow systems such as large filament boats, the Proportional Gain parameter may have to be set so low to maintain stability where the rate smoothly levels off but remains below the target value. In this case you will need to adjust the Integral Time parameter. This parameter works in reverse meaning the smaller the value the larger the effect. So, slightly decrease this parameter then watch the rate graph. The rate should ramp up to the target without overshoot. If the ramp takes too long then slowly decrease the Integral Time again and repeat these steps until you are satisfied with the control.



## 7. INPUT/OUTPUT CHARACTERISTICS

The following section describes the electrical characteristics of the MDC-360 inputs and outputs. All outputs are updated and inputs are sampled every 100 msec. In order to insure immunity to transients, inputs are not considered to have changed until the same input state is obtained on two successive input samples.

For this reason all input signals must have a minimum duration of at least 0.2 sec. Input signals lasting less than 100 msec. will be ignored while signals lasting between 100 and 200 msec. may or may not be recognized.

### 7.1 SOURCE CONTROL VOLTAGE OUTPUT

For maximum noise immunity, each two-terminal control voltage output pair is isolated from controller ground. Either terminal can be grounded within the user system, so the output can provide either a negative or positive output voltage range. In the event that the receiving equipment has an isolated input, one of the two lines should be grounded to avoid excessive voltage buildup on the otherwise isolated circuitry.

The voltage output range can be programmed (see Source Setup) for 2.5, 5.0 or 10 volts full scale. The output impedance is nominally 100 ohms. The outputs are short circuit protected with short circuit current limited to between 20 and 40 milliamps, though the outputs should not be short-circuited for long periods. The schematic appears in Figure 7-5.

#### CAUTION

**Long term shorting of any of the Source outputs may cause excessive temperature rise in the isolated power supply and should be avoided.**

### 7.2 SENSOR INPUT

The sensor oscillator is connected through a single coaxial cable. Sensor ground is common with the MDC-360 ground. Power to the sensor oscillator is carried on the center conductor of the coaxial cable. Power is supplied from the MDC-360 internal 5 volt supply through a 50 ohm resistor which accomplishes the dual function of properly terminating the 50 ohm coaxial cable and providing short circuit protection. The sensor buffer circuit is shown schematically in Figure 7-4.

### 7.3 DISCRETE OUTPUTS

Each Discrete Output is an isolated, independent, normally open relay output connected to one pin pair on the output connector. See **Table 8-4** for pin signal assignments.

### 7.4 DISCRETE INPUTS

The Input circuit for the Passive I/O card is shown in

Figure 7-1. The Passive inputs are activated by shorting the input's pins together. The inputs are internally pulled up to 5 vdc through a 4.7 Kohm resistor and incorporate a 10 millisecond filter to enhance noise immunity and provide protection from a momentary short.

The Input circuit for the Active I/O card is shown in Figure 7-2. The Active inputs are activated by supplying 12 to 120 volt AC or DC across the input pins. The inputs incorporate a 10 millisecond filter to enhance noise immunity and provide protection from a momentary short.

Pin assignments are shown in **Table 8-4**.

### 7.5 DIGITAL-TO-ANALOG CONVERTER OUTPUTS

Both of the DAC Analog outputs are single-ended and share the MDC-360 common ground, although a separate ground pin is provided for each of the two DAC outputs. The nominal output voltage range is 0 to 5.0 vdc and the output impedance is 10 Kohm nominal. The DAC analog output circuit is shown in Figure 7-3 and **Table 8-2** provides pin assignments. Refer to Section 4.3.3.7 for instructions on setting up the DAC parameters.

### 7.6 DIGITAL-TO-ANALOG CONVERTER CONTROL INPUTS

The DAC Control inputs are single-ended and share a common ground with the MDC-360. The inputs are activated by connecting them to ground through a jumper, mechanical switch or transistor. In the open state, the inputs are pulled up to 5 volts through a 4.7 Kohm resistor. The DAC control input circuit is shown in

Figure 7-1. Refer to **Figure 8-3** and **Table 8-1** for pin assignments and connector rating. The circuitry is located on the Main Processor board.

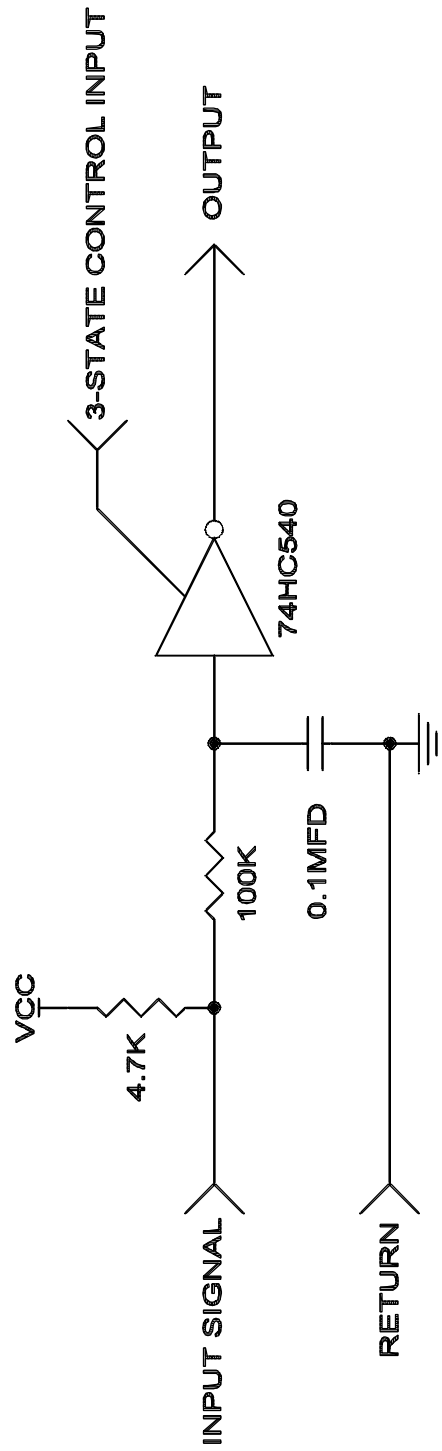

Figure 7-1 Passive Input Buffer circuit

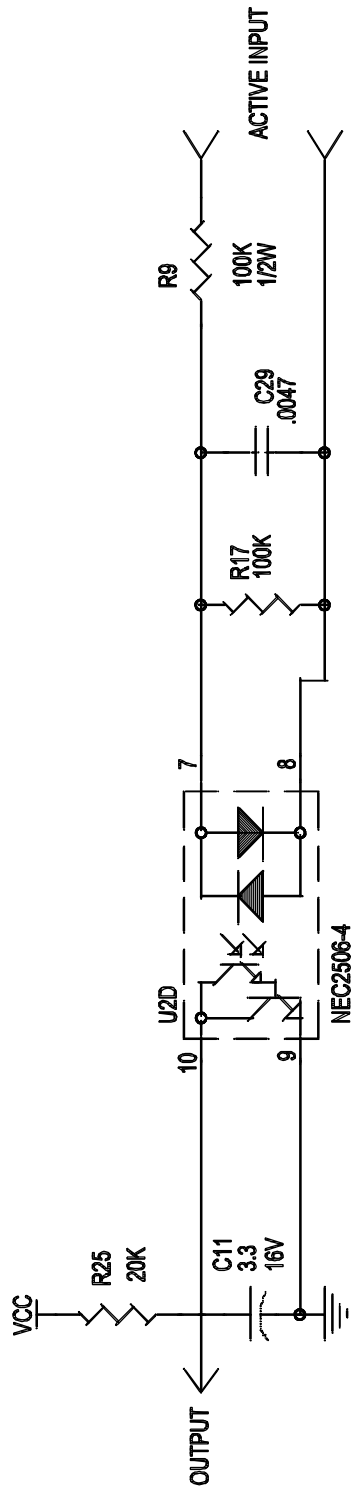

Figure 7-2 Active Input Buffer Circuit



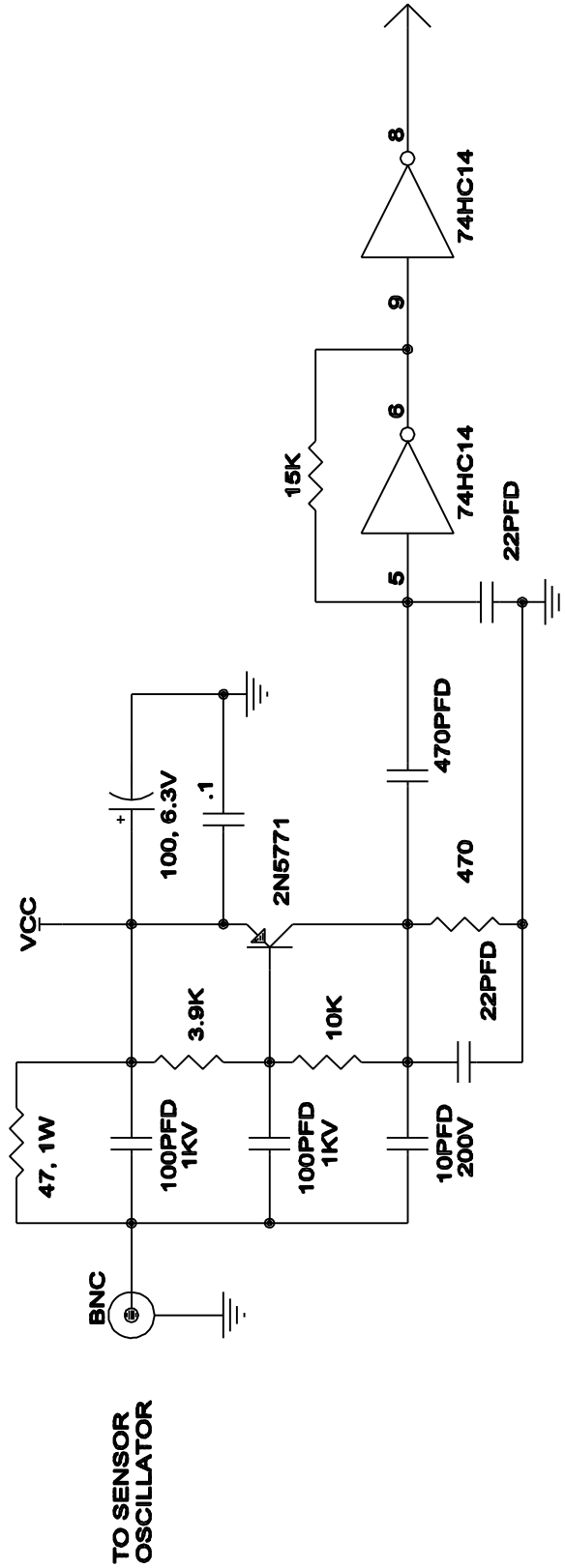

Figure 7-4 Sensor Input Buffer circuit





## **8. CONTROLLER INSTALLATION**

### **8.1 MOUNTING**

The MDC-360 is intended for rack mounting. For maximum operating ease it should be mounted at approximately eye level. If the MDC-360 is mounted in a rack containing other heat generating equipment, care should be taken that there is adequate ventilation to assure that the ambient temperature does not exceed the MDC-360's ambient temperature rating.

### **8.2 PROPER GROUNDING**

The MDC-360 was designed for maximum noise immunity and in most cases will require no special grounding precautions. In the event that noise sensitivity is noted in unusually noisy environments, more attention to proper grounding may be required. It is important that the rack in which the MDC-360 is mounted is tightly grounded to the vacuum station. This grounding is best accomplished by a multipoint mechanical connection through the structure itself or through grounding straps. Grounding straps should be as wide as practicable and can be foil or braid.

A small diameter copper conductor does not create an effective ground.

Although the D.C. resistance measured with such a connection may be low, the inductance can be high allowing rapidly changing currents to create large potential differences over the length of the ground wire. Multiple current paths significantly reduce the inductance, and since the inductance of a conductor is inversely proportional to its radius, wide straps will have the lowest inductance.

In particularly noisy environments it is desirable to ground the MDC-360 to the rack frame, or other good ground, by means of a grounding strap connected to the grounding lug provided on the rear panel.

### **8.3 EXTERNAL CONNECTIONS**

Most external connections are made through the rear panel (See Figure 8-2). The Remote Power Handset connector and a temporary RS-232 connection are, however, located on the front panel (Figure 8-1).

#### **8.3.1 POWER**

The power receptacle is an internationally approved type. A fuse, voltage selection board and RFI filter are part of the power receptacle assembly. The power plug must be removed to change the fuse or the voltage selection board position.

#### **8.3.2 VOLTAGE SELECTION**

The voltage selection is preset at the factory for a nominal input of 120 volts. However, the following nominal input voltages can be selected: 100, 120, 220, 240. For a 230 volt supply voltage, the 240 volt option should be used. Selection

of the desired nominal input voltage is accomplished by removing and reorienting the voltage selection board. Follow the steps listed below to select the proper line voltage.

Slide plastic cover to the left, exposing fuse and voltage selector PC board.

Remove fuse by pulling the “FUSE PULL” lever to the left.

Using a suitable tool, remove voltage selector PC board by pulling on the small hole located on the edge of the board.

Select the voltage by positioning the PC board so the desired voltage is indicated on the top left corner. Insert the board in place in this position.

Install the fuse and slide the plastic cover to the right. *The selected voltage will be visible through the plastic cover.*

### 8.3.3 GROUND LUG

In particularly noisy environments the MDC-360 should be grounded to the instrument rack, or other good ground, by means of the grounding lug in the rear panel. (See Figure 8-2).

### 8.3.4 REMOTE POWER HANDSET

Figure 8-1 shows the location of the receptacle into which the Remote Power Handset is plugged.

### 8.3.5 SOURCE-SENSOR

The system interface with the remote sensor oscillator is a 50 Ohm coax cable terminated with BNC connectors similar to AMP 225395-1 (plug) and AMP 225396-1 (jack). The plug on the Source-Sensor Board mates to a jack on the cable which is supplied with the oscillator.

The control voltage output is interfaced via a 4-pin, circular mini DIN connector equivalent to CINCH MDSS-4S. The pin layout is defined in Figure 8-4 and Table 8-2 supplies pin signal assignments.

### 8.3.6 RS-232 COMMUNICATION

There are two connections for the RS-232 interface port. A D9P connector is provided on the rear panel for permanent connection to the host computer. The pin layout is shown in Figure 8-5 and Table 8-3 lists pin signal assignments, including a definition of whether the signal is an output from the MDC-360 or an input to the MDC-360.

A DJ11 jack located on the front panel is provided for temporary connection to the host computer. Pin layout and pin signal assignments are shown in Figure 8-7 and Table 8-5.

The MDC-360 acts as DTE, and accordingly the 9-pin connector has ‘plug’ pins. It can be used with a DCE or a DTE host cable connection providing the sense of the RxD/TxD data lines and the control lines is observed. Pin 2 ‘TxD’ transmits

data from the MDC-360 to the host; pin 3 'RxD' receives data from the host. Pin 7 'CTS' is a control output signal, and pin 8 'RTS' is a control input signal.

In this implementation, pin 7 'CTS' means what it says, namely, this is an output control line, and when the MDC-360 asserts this control line 'true' the host can transmit to the MDC-360. On the other hand, pin 8 'RTS' is not quite what it may seem because this is a signal input to the MDC-360, and it is intended that the host should assert this line 'true' only when the MDC-360 is allowed to transmit data to the host. The MDC-360 does not generate an RTS 'request-to-send' as such for the host PC, so the host should assert pin 8 true whenever the MDC-360 is allowed to transmit to the host, without being asked to do so.

### 8.3.7 DISCRETE INPUT/OUTPUT

The MDC-360 has two types of I/O cards available. The Passive I/O card, PN# 179206, has TTL level (0 to 5 volt DC) inputs. The Passive inputs are pulled up to 5 volts internally through a 4.7 K OHM resistor and are set true, assuming the input's True level is set to Low, by shorting the input pins together. The Active I/O card, PN# 179239, has 12 to 120 volt AC/DC inputs. The Active inputs are set true, assuming the input's true level is set to High, by supplying 12 to 120 volt AC or DC across the input pins.

Both cards have the same relay output scheme and use the same D37P connector. The only difference is the Active I/O card's connector is keyed such that it can not be inserted into the Passive I/O card's connector.

There are two I/O card slots in the MDC-360 and they function identically. Either card type can be inserted into either I/O slot. The vacuum system side of the I/O cards requires a socket connector with receptacle crimp pins equivalent to AMP 205562-2. Figure 8-6 shows the pin configuration and Table 8-4 supplies pin signal assignments for both types of cards. Refer to Section 4.3.3.2 and 4.3.3.3 for I/O programming instructions.

### 8.3.8 DIGITAL-TO-ANALOG CONVERTER (DAC)

The Digital-to-Analog Converters are interfaced via a 7-pin, circular mini DIN connector. The vacuum system side of the interface requires a connector equivalent to the CINCH MDX-7PI. Figure 8-3 shows the connector and Table 8-1 shows the signal assignments.

# MDC-360 DEPOSITION CONTROLLER

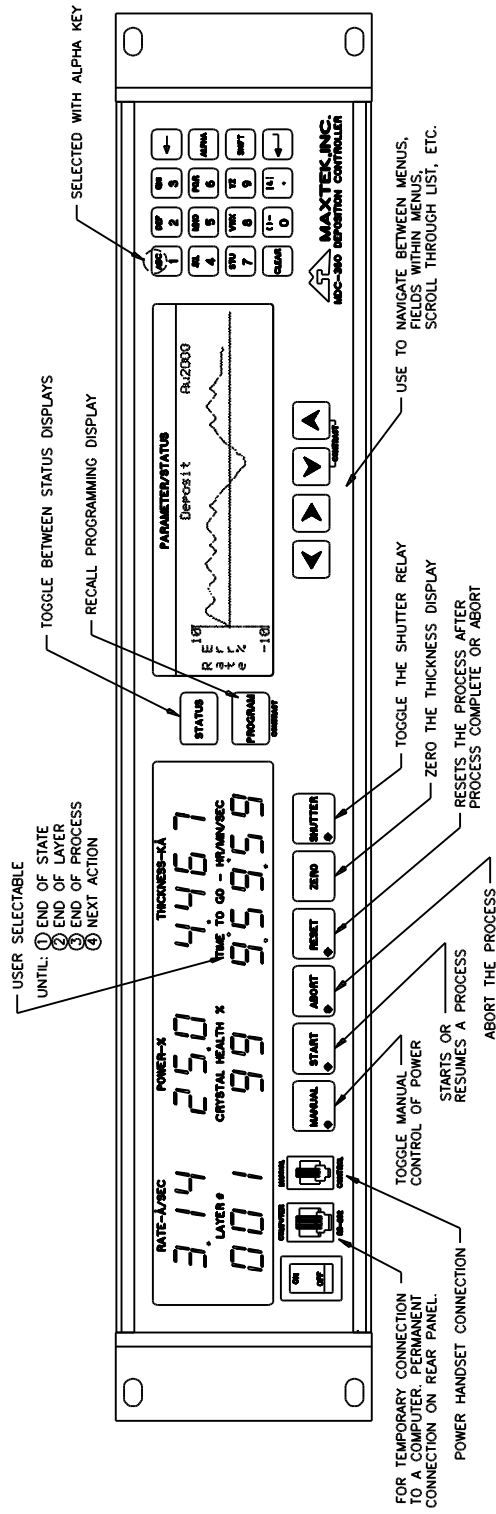

Figure 8-1 MDC-360 Front Panel



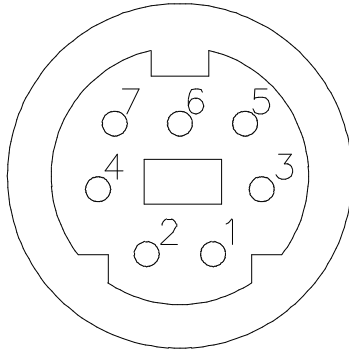

Figure 8-3 DAC socket connector pin out

Pin Number	Signal
1	Output #1
2	Output #1 Return
3	Output #2
4	Output #2 Return
5	Zero Scale Input
6	Full Scale Input
7	Scale Input Return

Table 8-1 DAC System Interface Connector Pin Assignments

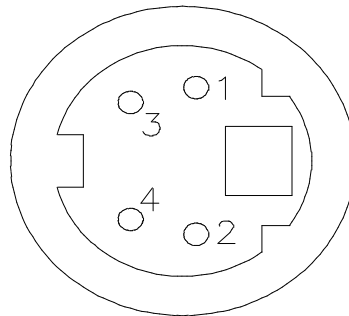

Figure 8-4 Source socket connector pin out

Pin Number	Signal	
	Source-Sensor Bd #1	Source-Sensor Bd #2
1	Source #2 Control Voltage	Source #4 Control Voltage
2	Source #2 Return	Source #4 Return
3	Source #1 Return	Source #3 Return
4	Source #1 Control Voltage	Source #3 Control Voltage

Table 8-2 Source Control System Interface Connector Pin Assignments

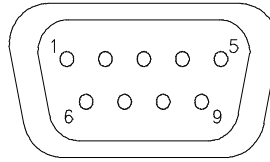

Figure 8-5 D9S DTE Rear-panel RS-232 socket connector

Pin Number	Signal	
	RS-232	RS-485
1	Not used	Rx- Input
2	Tx Output	Rx+ Input
3	Rx Input	Tx+ Output
4	Not used	Tx- Output
5	GND	GND
6	Not used	CTS- Input
7	CTS Input	CTS+ Input
8	RTS Output	RTS+ Output
9	Not used	RTS- Output

Table 8-3 D9 Rear Panel RS-232/RS-485 Connector Pin Assignments

## MDC-360 DEPOSITION CONTROLLER

---

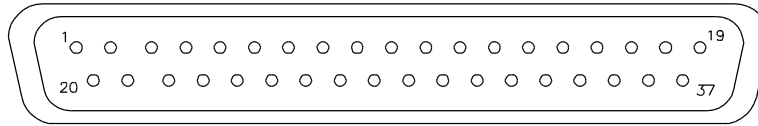

Figure 8-6 D37P Discrete I/O plug connector

Pin Number	Function
1, 20	Abort output
2, 21, 11	Output 1 (Common, N.O., N.C.)
3, 22, 29	Output 2 (Common, N.O., N.C.)
4,23	Output 3
5, 24	Output 4
6, 25	Output 5
7, 26	Output 6
8, 27	Output 7
9, 28	Output 8
30	Input 1
12	Input 1 Return
31	Input 2
13	Input 2 Return
32	Input 3
14	Input 3 Return
33	Input 4
15	Input 4 Return
34	Input 5
16	Input 5 Return
35	Input 6
17	Input 6 Return
36	Input 7
18	Input 7 Return
37	Input 8
19	Input 8 Return

Table 8-4 Discrete I/O System Interface Connector Pin Assignments

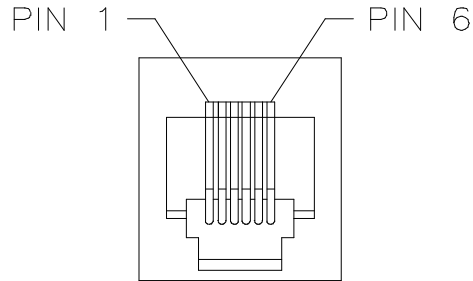

Figure 8-7 RJ11 Front Panel RS-232 Connector

Pin Number	Signal
1	Not used
2	CTS Input
3	Rx Input
4	RTS Output
5	Tx Output
6	GND

Table 8-5 RJ11 Front Panel RS-232 Connector Pin Assignments

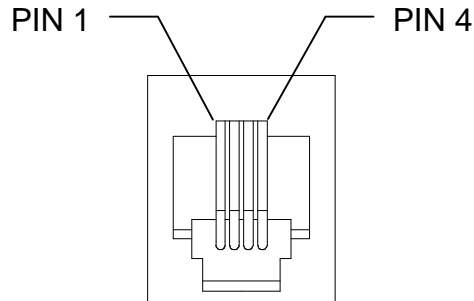

Figure 8-8 Front Panel Manual Power Connector

Pin Number	Signal
1	Decrease
2	GND
3	Abort
4	Increase

Table 8-6 Front Panel Manual Power Connector Pin Assignments



## **9. SYSTEM INSTALLATION**

### **9.1 SENSOR HEAD DESCRIPTION**

The sensor head is designed for simple installation and easy crystal replacement. It consists of two parts; a water cooled gold-plated 304 stainless steel housing which is permanently positioned in the vacuum system, and a quickly removable gold plated 304 stainless steel crystal holder which snaps into the housing. The crystal holder accommodates an industry standard .550" diameter crystal.

This design provides several convenient features in performance and use. The crystal holder is thermally shielded by the water cooled housing insuring excellent crystal performance in temperature environments up to 300° C. The sensor may be baked out with no water cooling to temperatures up to 250° C.

The exposed crystal electrode is fully grounded to effectively eliminate problems due to free electrons and RF interference.

The crystal holder is easily removed and installed even in awkward locations in the vacuum system. Once removed from the housing the crystal is still retained in the crystal holder by a snap on retainer. The crystal can be easily replaced without tools at a more convenient place, such as a clean bench.

The housing is provided with four tapped (4-40) holes for convenient mounting, 1/8" diameter X 5" long inlet and outlet water cooling tubes, and a coaxial connector (See Figure 9-4). The electrical connection to an instrumentation feedthrough is made with a 30" coaxial cable. Both ends of the cable terminate with standard Microdot® S-50 type connectors. Cable lengths up to 60" are available upon request.

### **9.2 SENSOR HEAD INSTALLATION**

The sensor head can be installed in any appropriate location in the vacuum chamber, preferably more than 10 inches from the evaporation source. It can be supported by its integral mounting bracket furnished with two #4-40 tapped holes. The internal (vacuum) cable, supplied with the sensor kit, connects the sensor head to the dual water/electrical feedthrough, to which the oscillator is attached. The cable length from sensor head to feedthrough connection should not exceed 60 inches. Shield the sensor cable in the most expedient way possible to protect it from radiation heat released from the evaporation source or the substrate heater.

The water cooling tube connects to the feedthrough by brazing or vacuum couplings. If necessary, both cable and water lines may be wrapped in aluminum foil to extend their useful life. The mounting tabs may be used to install a radiation shield to specifically protect the Microdot® connector and cable at its attachment point to the head.

Water cooling of the sensor head should always be provided except during short depositions at low temperatures. In all cases, head operating temperature should not exceed 100° C. Sufficient cooling for thermal environment to 300° C can be provided by approximately 0.2-gpm water flow.

Use a shutter to shield the sensor during initial soak periods to protect the crystal from any sputtering that may occur. If a small droplet of molten material hits the crystal, the crystal may be damaged and oscillation may cease.

### 9.3 SENSOR OSCILLATOR

The sensor oscillator, Figure 9-2, is designed to be used with industry standard 6 megahertz sensor crystals. The oscillator's characteristics enable it to obtain maximum life from the sensor crystal.

The oscillator is supplied with a 6" coaxial cable and a 10' coaxial cable. The 6" cable interconnects the oscillator and the feedthrough. The 10' cable interconnects the oscillator and the MDC-360. This single coaxial cable provides both power for the oscillator and the signal output for the controller. Cables of any length are available upon request for replacing the 10' cable. A schematic of the oscillator is shown on Figure 9-1.

#### 9.3.1 INSTALLATION

Connect one end of the 10-foot oscillator cable to the BNC connector on the appropriate source-sensor board at the rear of the MDC-360. Connect the other end of the cable to the oscillator with the arrow pointed toward the sensor head. The oscillator connects to the feedthrough leading into the vacuum chamber using a 6 in. cable.

#### **CAUTION**

**Always use the cables supplied by Maxtek to make the connections. Failure to make this connection correctly will create a mismatch in the impedance of the oscillator circuit.**

### 9.4 INSTRUMENTATION FEEDTHROUGH

A 1 inch diameter, O-Ring sealed feedthrough (IF-111, Figure 9-3) or a 2-3/4 inch Conflat® flange seal are available with 1/8 inch source and return water cooling lines, and internal and external coaxial cable connectors. Base plate thickness up to one inch can be accommodated.

RF interference and free electrons are effectively shielded from the signal connector through the use of fully closed coaxial cable connections. A standard coaxial cable with a Microdot® S-50 connector mates the internal feedthrough connector to the sensor head. The feedthrough has a standard BNC connector for the coaxial connection to the sensor oscillator.

### 9.5 SENSOR CRYSTAL REPLACEMENT

The Sensor Head is especially designed for easy sensor crystal replacement and reliable operation. The crystal lies in a drawer that slides into the sensor housing. Pull the drawer straight out of the sensor housing by gripping the drawer's edges between thumb and forefinger. With the drawer removed, pull straight up on the retainer spring clip and shake out the spent crystal. Drop a new crystal into the

drawer with the full electrode side down and the pattern electrode side up. Make sure the crystal is properly seated in the bottom of the drawer. Install the retainer clip by gently pressing it onto the drawer. The retainer clip should snap into the drawer. All three retaining legs must be fully engaged onto the drawer housing. Replace the drawer into the sensor housing. The drawer should slide in easily and snap into place.

Removal and replacement of sensor crystals should be performed in a clean environment. An isolated clean work bench is recommended for crystal replacement. To prevent crystal contamination, use clean lab gloves or plastic tweezers when handling the crystal and keep the new crystals in a closed plastic case. When handling the drawer always hold it by the edges to avoid touching the crystal surface.

### **9.6 TYPICAL SYSTEM INSTALLATION**

A typical system installation is shown in Figure 9-5. Installation can vary depending on the application

# MDC-360 DEPOSITION CONTROLLER

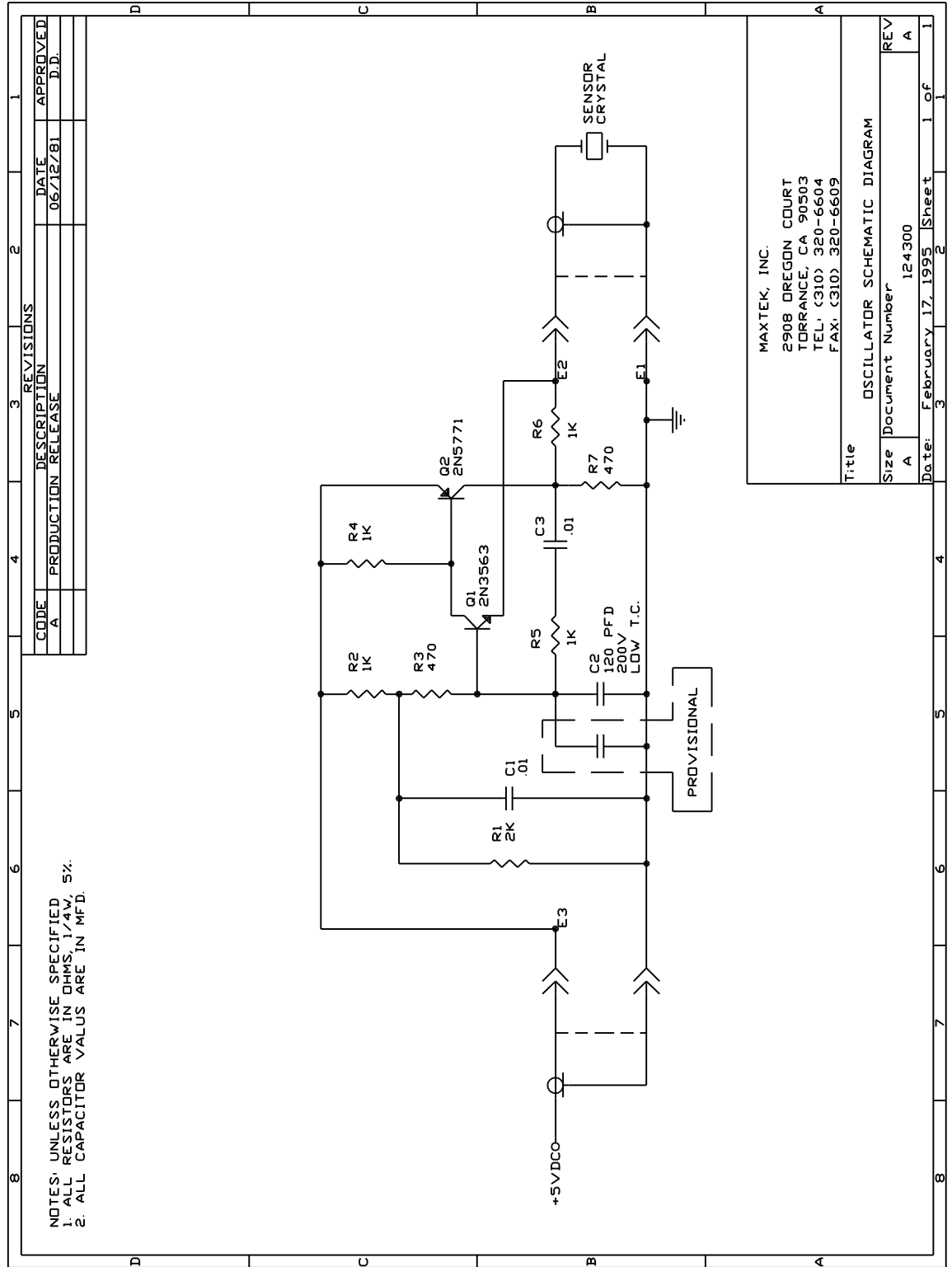

Figure 9-1 Sensor Oscillator Schematic

# MDC-360 DEPOSITION CONTROLLER

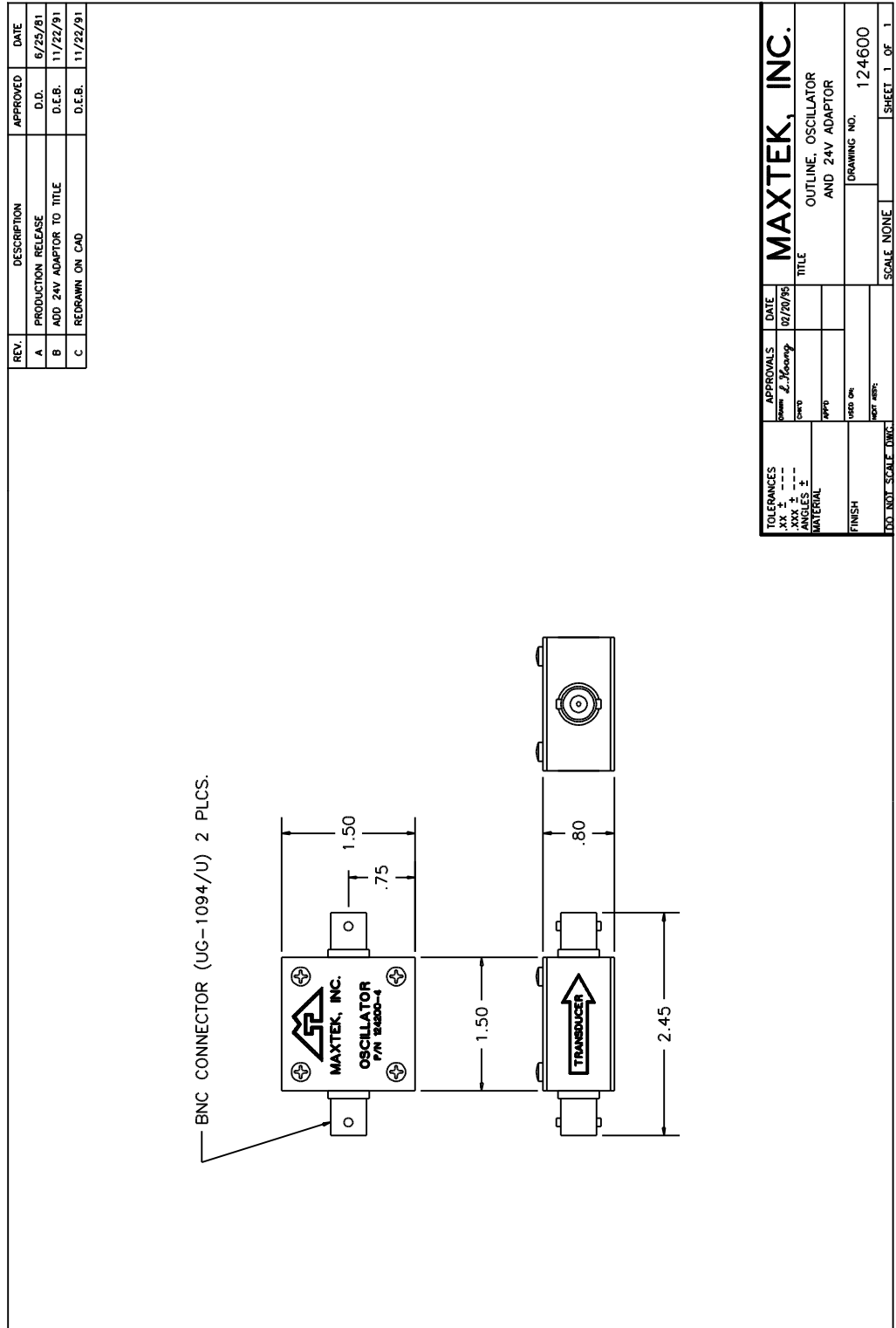

Figure 9-2 Sensor Oscillator Outline

# MDC-360 DEPOSITION CONTROLLER

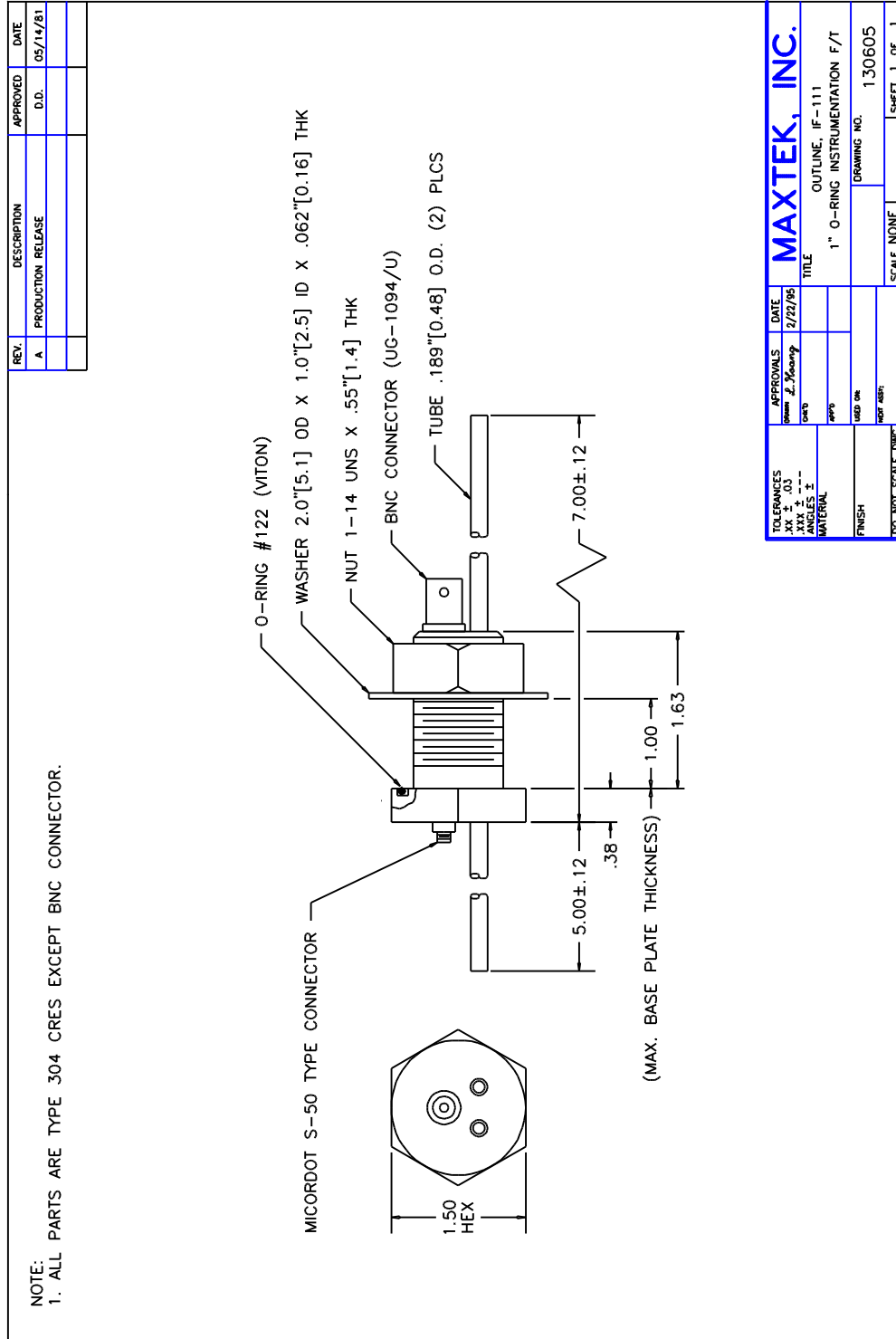

Figure 9-3 IF-111 Instrumentation Feedthrough Outline



# MDC-360 DEPOSITION CONTROLLER

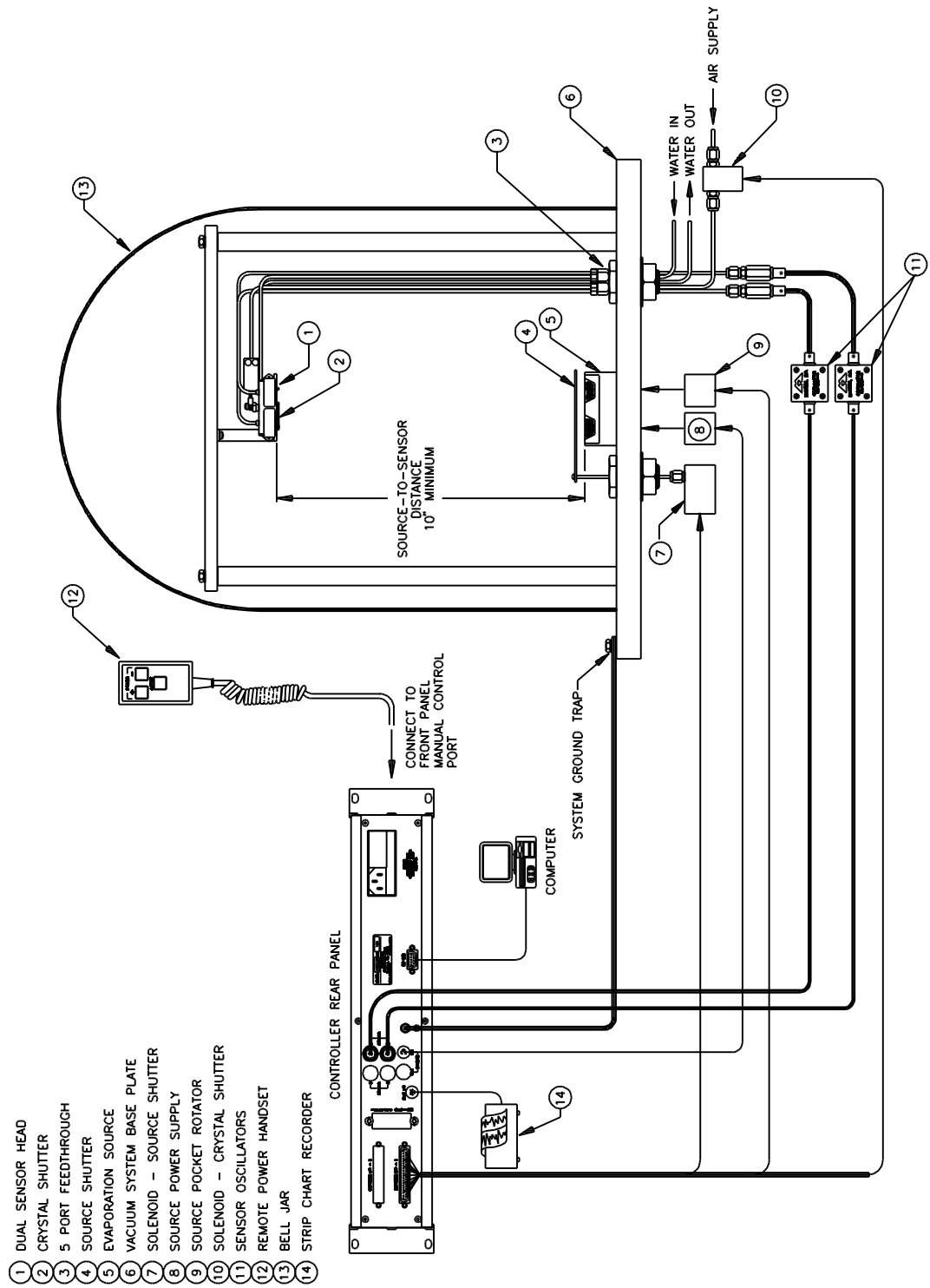

Figure 9-5 Typical System Installation

## **10. THEORY OF OPERATION**

### **10.1 BASIC MEASUREMENT**

The MDC-360 uses a quartz crystal as the basic transducing element. The quartz crystal itself is a flat circular plate approximately 0.55 in. (1.40 cm) in diameter and 0.011-0.013 in. (28-33mm) thick for 6 and 5 MHz. The crystal thickness is inversely proportional to the crystal frequency. The crystal is excited into mechanical motion by means of an external oscillator. The unloaded crystal vibrates in the thickness shear mode at approximately the frequency of the specified crystal. The frequency at which the quartz crystal oscillates is lowered by the addition of material to its surface.

### **10.2 FILM THICKNESS CALCULATION**

Early investigators noted that if one assumed that the addition of material to the surface produced the same effect as the addition of an equal mass of quartz, the following equation could be used to relate the film thickness to the change in crystal frequency.

$$TK_f = \frac{N_q \cdot r_q}{r_f \cdot f^2} (f_q - f) \quad (1)$$

where:

$N_q$  = Frequency constant for an "AT" cut quartz crystal vibrating in thickness shear (Hz x cm).

$N_q = 1.668 \times 10^5$  Hz x cm.

$r_q$  = Density of quartz g/cm<sup>3</sup>.

$f_q$  = Resonant frequency of uncoated crystal.

$f$  = Resonant frequency of loaded crystal.

$Tk_f$  = Film thickness.

$r_f$  = Density of film g/cm<sup>3</sup>.

This equation proved to be adequate in most cases, however, note that the constant of proportionality is not actually constant because the equation contains the crystal frequency which of course changes as the film builds up. Because the achievable frequency change was small enough, the change in scale factor fell within acceptable limits.

Improvements in sensor crystals and oscillator circuits resulted in a significant increase in achievable frequency shift. Low cost integrated digital circuits became available allowing a significant increase in basic instrument accuracy. As a result of the above two factors, the frequency squared term in the scale factor became a significant limitation on the measurement accuracy.

If the period of oscillation is measured rather than the frequency, 1/period can be substituted for frequency resulting in the following equation.

$$TK_f = \frac{N_q \cdot r_q}{r_f} (t - t_q) \quad (2)$$

where:

$t$  = Period of loaded crystal (sec.)

$t_q$  = Period of uncoated crystal (sec.)

Note: Units of are cm/sec.

Note that the constant of proportionality in this equation is constant. This approach was demonstrated to be a significant improvement over frequency measurement and was widely adopted.

The original assumption that the addition of a foreign material to the surface of the crystal produced the same effect as that of the addition of an equal mass of quartz was of course, questionable and indeed work with crystals heavily loaded with certain materials showed significant and predictable deviation between the actual measured film thickness and that predicted by equation 2. Analysis of the loaded crystal as a one dimensional composite resonator of quartz and the deposited film led to the equation below:

$$TK_f = \left( \frac{r_q}{r_f} \right) \cdot N_q \cdot \left( \frac{t}{PR_z} \right) \cdot \arctan \left[ R_z \tan P \left( \frac{t - t_q}{t} \right) \right] \quad (3)$$

where:

$R_z$  is referred to as the Acoustic Impedance Ratio and is obtained by dividing the acoustic impedance of quartz by the acoustic impedance of the deposited film.

This equation introduces another term into the relationship which is the ratio of the acoustic impedance of quartz to the acoustic impedance of the deposited film. The acoustic impedance is that associated with the transmission of a shear wave

in the material. Note that if the acoustic impedance ratio is equal to one, quartz on quartz, equation 3 reduces to equation 2.

Although the above equation still involves a number of simplifying assumptions, its ability to accurately predict the film thickness of most commonly deposited materials has been demonstrated.

The use of microprocessors allows an equation as complex as equation 3 to be solved economically and the above equation is implemented in the MDC-360.

The basic measurement is period, which can be thought of as a measurement of equivalent quartz mass.

The actual film mass on the crystal is then found by applying the acoustic impedance correction factor.

At the beginning of the deposit, or when the thickness indication is zeroed, the initial equivalent quartz mass and the initial corrected film mass are stored. For each subsequent measurement the new corrected total film mass is calculated, and the film mass deposited since the start of deposit is determined by subtracting the initial corrected film mass from the total corrected film mass.

The film thickness on the crystal is calculated by dividing the film mass by the film density.

The film thickness on the substrates is then calculated by multiplying the film thickness on the crystal by a tooling factor.

If the acoustic impedance parameter is changed following a deposition both the total and the initial film masses are recalculated. This allows the effect of the changed parameter value to be immediately displayed and provides a relatively straightforward method of empirically determining the acoustic impedance if it is not available. See section: 10.6.3.

### 10.3 CRYSTAL HEALTH CALCULATION

Crystal Health decreases from a value of 100% for an uncoated crystal blank to 0 at a total deposited aerial mass of  $25 \text{ mg/cm}^2$ . This value corresponds to a crystal frequency shift of approximately 1.5 MHz, or an aluminum thickness of  $925 \text{ \AA}$ .

Very few materials can be deposited to this thickness without producing a crystal failure, so that a crystal health of zero will not normally be achieved and indeed for some materials the crystal health may never get below 90%.

In order to establish the point at which the crystal should be changed, several trial runs should be made to determine the point at which the crystal fails and subsequent crystals should then be replaced well in advance of this point.

Because the crystal health is determined from the calculated film mass, the Acoustic Impedance parameter will effect the displayed crystal health.

### 10.4 RATE CALCULATION

The deposition rate is calculated by dividing the change in thickness between measurements by the time between measurements. The rate is then filtered by a three pole digital filter to filter out quantizing and sampling noise introduced by the discrete time, digital nature of the measurement process. The above filter has an effective time constant of about 2 seconds. Following a step the displayed rate will settle to 95% of the final value in 5 sec.

### 10.5 RATE CONTROL

Deposition rate control is achieved in the MDC-360 by comparing the measured thickness rate with the desired thickness rate. The rate error and the rate of change of rate error are then used to determine how much to increment the power up or down.

The amount the power is incremented is also affected by the response parameter. The response parameter is divided by 50, squared and then used as a multiplier in the determination of delta power.

The rate error is divided by the programmed rate and multiplied by 100 to obtain the displayed percent rate error.

### 10.6 EMPIRICAL CALIBRATION

For many film materials the film density and acoustic impedance is known to sufficient accuracy that the values can be used directly, and empirical calibration of these parameters is not necessary. A library of material names, density and acoustic impedance of the more commonly deposited materials is stored in the MDC-360 memory. These materials are also listed in Table 9.1.

If the values of the density and acoustic impedance are not known they can be calibrated empirically as described below.

Calibration requires the establishment of the film density, the tooling factor and the acoustic impedance in this order. If the approximate value of the parameters is known they should be used initially. If the acoustic impedance is not known use the value 8.83, the value for quartz.

#### 10.6.1 FILM DENSITY

Establishing the film density can be accomplished by depositing a trial film on several test substrates placed around and as close as possible to the sensor crystal and in the same plane. The trial deposition should be thick enough to allow an independent measurement of the film on the test substrates to be made with adequate precision using an optical interferometer or surface measuring device.

When making the trial deposition, use a fresh crystal and remember to write down the final thickness reading displayed by the MDC-360, as this will be needed in the calculation. If the acoustic impedance parameter has been accurately established previously, a fresh crystal is not required.

Determine the average film thickness on the test substrates and use the following equation to calculate the material's density:

$$\text{Density} = (\text{Displayed Thickness}/\text{Average Measured Thickness}) * \text{Density}(\text{test})$$

Where Density(test) is the density parameter setting used during the calibration run.

Once the calibration procedure is complete, the programmed film density is correct for this particular film.

### 10.6.2 TOOLING FACTOR

Having established the film density the tooling factor should be established. Place several test substrates at representative locations in the deposition fixture. Again deposit a trial film as above using the known film density, and a fresh crystal unless the programmed acoustic impedance is known to be correct. Remember to write down the final thickness reading displayed by the MDC-360, as this will be needed in the calculation. Determine the average film thickness on the test substrates. If the average measured thickness differs from the displayed thickness, use the following equation to calculate the correct tooling factor.

$$\text{Tooling} = (\text{Average Measured Thickness}/\text{Displayed Thickness}) * \text{Tooling}(\text{test})$$

Where Tooling(test) is the tooling parameter setting used during the calibration run.

### 10.6.3 ACOUSTIC IMPEDANCE

Establishment of the acoustic impedance requires that the crystal be heavily loaded. Continue to deposit on the sensor crystal until the crystal health approaches 50% or until the crystal is approaching the end of its useful life. Deposit another trial run as above but this time use the manual power mode instead of the automatic mode. Measure the average film thickness on the test substrates and this adjust the acoustic impedance parameter up or down to bring the displayed thickness into agreement with the measured thickness. This calibrates the acoustic impedance parameter.

The MDC-360 is now fully calibrated for the film in question and should produce consistent and accurate films.

## MDC-360 DEPOSITION CONTROLLER

Table 10-1 Material Density and Acoustic Impedance Value

Material	Symbol	Density	Impedance
Aluminum	Al	2.70	8.17
Aluminum Oxide	Al <sub>2</sub> O <sub>3</sub>	3.97	26.28
Antimony	Sb	6.62	11.49
Arsenic	As	5.73	9.14
Barium	Ba	3.5	4.20
Beryllium	Be	1.85	16.26
Bismuth	Bi	9.8	11.18
Boron	B	2.54	22.70
Cadmium	Cd	8.64	12.95
Cadmium Sulfide	CdS	4.83	8.66
Cadmium Telluride	CdTe	5.85	9.01
Calcium	Ca	1.55	3.37
Calcium Fluoride	CaF <sub>2</sub>	3.18	11.39
Carbon (Diamond)	C	3.52	40.14
Carbon (Graphite)	C	2.25	2.71
Chromium	Cr	7.20	28.95
Cobalt	Co	8.71	25.74
Copper	Cu	8.93	20.21
Copper (I) Sulfide (alpha)	Cu <sub>2</sub> S	5.6	12.80
Copper (I) Sulfide (beta)	Cu <sub>2</sub> S	5.8	13.18
Copper (II) Sulfide	CuS	4.6	10.77
Dysprosium	Dy	8.54	14.72
Erbium	Er	9.05	11.93
Europium	Eu	5.244	----
Gadolinium	Gd	7.89	13.18
Gallium	Ga	5.93	14.89
Gallium Arsenide	GaAs	5.31	5.55
Germanium	Ge	5.35	17.11
Gold	Au	19.30	23.18
Hafnium	Hf	13.09	24.53
Holmium	Ho	8.8	15.2
Indium	In	7.30	10.50
Indium Antimonide	InSb	5.76	11.48
Iridium	Ir	22.40	68.45
Iron	Fe	7.86	25.30
Lanthanum	La	6.17	9.59
Lead	Pb	11.30	7.81
Lead Sulfide	PbS	7.50	15.60
Lithium	Li	0.53	1.50
Lithium Fluoride	LiF	2.64	11.41
Magnesium	Mg	1.74	5.48
Magnesium Fluoride	MgF <sub>2</sub>	3.0	13.86
Magnesium Oxide	MgO	3.58	21.48

## MDC-360 DEPOSITION CONTROLLER

Manganese	Mn	7.20	23.42
Manganese (II) Sulfide	MnS	3.99	9.39
Mercury	Hg	13.46	11.93
Molybdenum	Mo	10.20	34.36
Nickel	Ni	8.91	26.68
Niobium	Nb	8.57	17.91
Palladium	Pd	12.00	24.73
Platinum	Pt	21.40	36.04
Potassium Chloride	KC	1.98	4.31
Rhenium	Re	21.04	58.87
Rhodium	Rh	12.41	42.05
Samarium	Sm	7.54	9.92
Scandium	Sc	3.0	9.70
Selenium	Se	4.82	10.22
Silicon	Si	2.32	12.40
Silicon (II) Oxide	SiO	2.13	10.15
Silicon Dioxide (fused quartz)	SiO <sub>2</sub>	2.2	8.25
Silver	Ag	10.50	16.69
Silver Bromide	AgBr	6.47	7.48
Silver Chloride	AgCl	5.56	6.69
Sodium	Na	0.97	1.84
Sodium Chloride	NaCl	2.17	5.62
Strontium	Sr	2.620	----
Sulphur	S	2.07	3.86
Tantalum	Ta	16.60	33.70
Tantalum (IV) Oxide	Ta <sub>2</sub> O <sub>5</sub>	8.2	29.43
Tellurium	Te	6.25	9.81
Terbium	Tb	8.27	13.38
Thallium	Tl	11.85	5.70
Tin	Sn	7.30	12.20
Titanium	Ti	4.50	14.06
Titanium (IV) Oxide	TiO <sub>2</sub>	4.26	22.07
Tungsten	W	19.30	54.17
Tungsten Carbide	WC	15.60	58.48
Uranium	U	18.70	37.10
Vanadium	V	5.96	16.66
Ytterbium	Yb	6.98	7.81
Yttrium	Y	4.34	10.57
Zinc	Zn	7.04	17.18
Zinc Oxide	ZnO	5.61	15.88
Zinc Selenide	ZnS	5.26	12.23
Zinc Sulfide	ZnS	4.09	11.39
Zirconium	Zr	6.51	14.72



## 11. COMPUTER INTERFACE

### 11.1 GENERAL

The various computer interfaces of the Maxtek MDC-360 Deposition Controllers permit complete remote control using a personal computer. There are three types of computer interfaces offered. The MDC-360 comes standard with an RS-232 serial interface. Both RS-485 and IEEE-488 interfaces are available as options.

### 11.2 RS-232 SERIAL INTERFACE

The standard RS-232 serial interface of the MDC-360 allows one 360 to be connected to any other device with as RS-232 serial interface. There are two connections for the RS-232 interface port. A D9P connector is provided on the rear panel for permanent connection to the host computer. The pin layout is shown in **Figure 8-5** and **Table 8-3** lists pin signal assignments, including a definition of whether the signal is an output from the MDC-360 or an input to the MDC-360.

A DJ11 jack located on the front panel is provided for temporary connection to the host computer. Pin layout and pin signal assignments are shown in **Figure 8-7** and **Table 8-5**.

The MDC-360 acts as DTE, and accordingly the 9-pin connector has 'plug' pins. It should be connected to the host computer via a straight 9-pin female to 9-pin female cable. Straight means pin 1 is connected to pin 1, pin 2 to pin 2, etc.

In the case where a special cable is required, remember to observe the sense of the RxD/TxD data lines and the control lines. Pin 2 'TxD' transmits data from the MDC-360 to the host; pin 3 'RxD' receives data from the host. Pin 7 'CTS' is a control input signal, and pin 8 'RTS' is a control output signal.

In this implementation, pin 7 'CTS' means what it says, namely, this is an input control line to the 360 which must be asserted 'true' before the 360 is clear to send data to the host. Pin 8 'RTS' is an output from the 360 indicating to the host that the 360 is ready to receive data from the host. The MDC-360 will always assert RTS 'true' unless its input buffer is full from too much incoming data.

The MDC-360's RS-232 port is automatically set up to operate with the following specifications:

9600 Baud, 8 Bit data, No Parity, 1 Stop bit

### 11.3 RS-485 SERIAL INTERFACE

The optional RS-485 serial interface of the MDC-360 allows connection to up to 32 separate devices equipped with RS-485. The RS-485 serial interface is also ideal in electrically noisy environments and in applications where long cables are required. The RS-485 port of the MDC-360 is the same D9P connector on the rear panel used for RS-232. The pin layout is shown in **Figure 8-5** and **Table 8-3**

lists pin signal assignments, including a definition of whether the signal is an output from the MDC-360 or an input to the MDC-360.

The DJ11 jack located on the front panel and labeled RS-232 can not be used if RS-485 is installed.

The MDC-360's RS-485 port is automatically set up to operate with the following specifications:

9600 Baud, 8 Bit data, No Parity, 1 Stop bit

### 11.4 IEEE-488 PARALLEL INTERFACE

The optional IEEE-488 interface provides the MDC-360 with the ability to communicate with computers and other devices over a standard IEEE-488 interface bus. The IEEE-488 interface, also known as GPIB or HPIB, provides an eight bit parallel asynchronous interface between up to 15 individual devices on the same bus. This means that one computer equipped with an IEEE-488 interface card can communicate with up to 14 MDC-360 controllers or other devices.

The pin layout of the IEEE-488 port is shown in **Figure 8-5** and **Table 8-3** lists pin signal assignments, including a definition of whether the signal is an output from the MDC-360 or an input to the MDC-360.

Both of the RS-232 serial ports can still be used with IEEE-488 installed. However, since both interfaces use the same input and output message buffers, they should not be used at the same time. This will result in communication errors.

### 11.5 PROTOCOL

All communications between the computer and the MDC-360 are in the form of message character strings with the format:

\* Two byte header - FFh,FEh i.e. Chr\$(255),Chr\$(254)

\*One byte controller address - The controller address byte defines the controller that should receive the message, or should respond to the message by transmitting data. The controller address will range from 0 to 32 (set via Edit System Setup, Edit Utility Setup, Interface Address). A controller address of zero will be received by all controllers except in the case of the IEEE-488 interface. With this interface, only the addressed device will receive the message.

\*One byte instruction code.

\*One byte message length.

\* 0-249 byte message.

\* One byte checksum, for the instruction code byte, message length byte and the 0-249 byte message.

The checksum is the compliment of the one byte sum of all bytes from, and including, the instruction code to the end of the message. If the one byte sum of all these bytes is added to the checksum, the result should equal 255.

If the sum of all bytes occupies more than one byte, a single byte checksum can be generated using the expression:  $\text{checksum} = \text{!(Sum MOD 256)}$ , i.e. the checksum is the complement of the remainder byte which results from dividing the sum of all bytes by 256.

## 11.6 DATA TYPES

There are three data types stored in the MDC-360: one byte, two byte, and three byte parameters. All data types are stored as integers in binary format with the most significant byte first. The one byte data types are either ASCII characters, numeric values (0-255), or 8 bit registers. Some of the multiple byte data types are decimal values stored as integers. To convert these values to their decimal equivalent, use the following equation:

$$\text{Decimal Value} = (\text{Integer Value}) / (10 * \text{DP})$$

where DP is the value's decimal point position. The decimal point positions for all the parameters are constant and are given in tables along with the parameters' range.

## 11.7 MESSAGE RECEIVED STATUS

Following the receipt of each message, the controller will send a one-byte 'received status' message, indicating how the message was received, with the following format:

Header  
Address  
Inst=253  
Length=2  
Instruction Code  
Receive code  
Checksum

A value of 253 for the instruction byte indicates that this is a received status message. The Instruction Code byte indicates the instruction code of the message that was received. The following table shows a list of possible receive codes:

Receive Code	Description
0	Message received O.K.
1	Invalid checksum.
2	Invalid instruction code.
3	Invalid message length.
4	Parameter(s) out of range.

## MDC-360 DEPOSITION CONTROLLER

---

5	Invalid message.
6	Process undefined. Can't add layer.
7	Insufficient layer space. Can't add layer.
8	Can't send process log data while in process.

### 11.8 INSTRUCTION SUMMARY

The following table is a list of valid instruction codes.

Instruction Code	Description
0	Remote activation of controller
1	Send controller configuration parameters
2	Send utility parameters
3	Receive utility parameters
4	Send controller time and date
5	Receive controller time and date
6	Send a material
7	Receive a material
8	Send a material list
9	Send number of undefined layers
10	Send a process
11	Receive a process
12	Delete a process
13	Send a process layer
14	Insert process layer
15	Replace a process layer
16	Delete a process layer
17	Send a process list
18	Send source setup
19	Receive source setup
20	Send sensor setup
21	Receive sensor setup
22	Send Input setup
23	Receive Input setup
24	Send Output setup
25	Receive Output setup
26	Send Action setup
27	Receive Action setup
28	Send controller status
29	Start process
30	Send run-time values
31	Initiate automatic data logging
32	Internal Command
33	Set Active Source Power
34	Internal Command
35	Internal Command

## MDC-360 DEPOSITION CONTROLLER

---

36	Send Process Log Directory
37	Send Process Log Data
38	Initiate Remote Action Command
39	Send Individual Run-time Value Command

### 11.9 INSTRUCTION DESCRIPTIONS

The following is a description of all the valid instructions along with an example of how they are used. All the examples assume the controller address is 1.

#### 1. Remote activation of controller (Code #0)

This instruction initiates a key press of the MDC-360's keyboard. The valid key codes are shown in the following table:

Remote Activation Code	Description
1	Program key
2	Manual key
4	Shutter key
8	Zero key
16	Reset key
32	Abort key
64	Start key

Format: Header, Instruction=1, Length=1, Key Code, Checksum

Example: To initiate a zero thickness instruction the computer would send:

Chr\$(255)+Chr\$(254)+Chr\$(1)+Chr\$(0)+Chr\$(1)+Chr\$(8)+Chr\$(246)

#### 2. Send controller hardware configuration (Code #1)

Instructs the controller to send controller configuration data to the host computer. The following is a description of the configuration data:

Name	Length (bytes)	Message
Software Version	30	MDC-360 Software Version X.X
Source/Sensors	1	(2 or 4)
I/O Ports	1	(1 or 2)
Communication Port	1	(1=RS232, 2=RS-485, 3=IEEE488)
Real Time Clock	1	(0=No, 1=Yes)
Total 34 bytes		

Example: To instruct the controller to send the hardware configuration data the computer would send:

Chr\$(255)+Chr\$(254)+Chr\$(1)+Chr\$(1)+Chr\$(0)+Chr\$(254)

#### 3. Send utility parameters (Code #2)

Instructs the controller to send the utility parameters to the host computer. A description of the utility parameter list is as follows:

## MDC-360 DEPOSITION CONTROLLER

Parameter Name	Length (bytes)	Range
DAC#1 Output	1	(22=Rate, 23=RateDev, 24=Pwr, 25=Thk)
DAC#1 Range	1	(26=2 Digit, 27=3 Digit)
DAC#2 Output	1	(22=Rate, 23=RateDev, 24=Pwr, 25=Thk)
DAC#2 Range	1	(26=2 Digit, 27=3 Digit)
Thickness Graph Scale	1	(26=2 Digit, 27=3 Digit)
Crystal Frequency	1	(30=2.5mhz, 31=3.0MHz, 32=5.0mhz, 33=6.0MHz, 34=9.0mhz, 35=10.0MHz)
Data Points/min	1	(38=30 ppm, 39=60 ppm, 40=120 ppm, 41=300 ppm, 42=600ppm)
Simulate Mode	1	(20=Off, 21=On)
Interface Address	1	(1-32)
Attention Volume	1	(0-10)
Alert Volume	1	(0-10)
Alarm Volume	1	(0-10)
Pause on layer complt	1	(0=No, 1=Yes)
Time To Go Display	1	(72=Estimated Layer, 73=Est. State, 74=Elapsed Process, 75=Elapsed Layer, 76=Elapsed State)
Rate Graph	1	(78=Enabled, 79=Disabled)
Power Graph	1	(78=Enabled, 79=Disabled)
Thickness Graph	1	(78=Enabled, 79=Disabled)
Rate Deviation Graph	1	(78=Enabled, 79=Disabled)
Source/Sensor Status	1	(78=Enabled, 79=Disabled)
I/O Status	1	(78=Enabled, 79=Disabled)
Total 20 bytes		

Example: To instruct the controller to send the utility parameters the computer would send:

Chr\$(255)+Chr\$(254)+Chr\$(1)+Chr\$(2)+Chr\$(0)+Chr\$(253)

#### 4. Receive utility parameters (Code #3)

Instructs the controller to enter all the incoming utility parameters into memory.

#### 5. Send controller time (Code #4)

Instructs the controller to send the its current time and date to the host computer. The time and date are sent as strings. A description of the time and date parameter list is as follows:

Parameter Name	Length (bytes)	Range
Seconds	2	(0-59)
Minutes	2	(0-59)
Hours	2	(1-23)
Day of month	2	(1-28/29/30/31)
Month	2	(1-12)

## MDC-360 DEPOSITION CONTROLLER

Year	2	(0-99)
Total 12 bytes		

Example: To instruct the controller to send the time and date the computer would send:

Chr\$(255)+Chr\$(254)+Chr\$(1)+Chr\$(4)+Chr\$(0)+Chr\$(251)

### 6. Receive time and date (Code #5)

Instructs the controller to enter the incoming time and date into memory. The values must be in the order, range, and format listed above.

### 7. Send a material (Code #6)

Instructs the controller to send all the material parameters for material # *n* to the host computer. A description of the material parameter list is in the table below:

Parameter name	Len bytes	Byte Offset	Decimal Pt. Position	Range	Units
Material #	1	0	*	(0-31)	None
Material Name	10	1	*		
Sensor #	1	11	*	(1-4)	None
Crystal #	1	12	*	(1-8)	None
Source #	1	13	*	(1-4)	None
Pocket #	1	14	*	(1-8)	None
Rate Establish Time	1	15	*	(0-99)	Seconds
Power Alarm Delay	1	16	*	(0-99)	Seconds
Sample Dwell %	1	17	*	(0-100)	%
Crystal Fail	1	18	*	4 = Halt 5 =TimePwr 6 =Switch	
Backup Sensor #	1	19	*	(1-4)	None
Backup Crystal #	1	20	*	(1-8)	None
Material Density	2	21	2	80-9999	0.01 gm/cm <sup>3</sup>
Acoustic Impedance	2	23	2	400-5999	0.01 gm/cm <sup>2</sup> /sec
Tooling Factor	2	25	1	100-4999	0.1%
Proportional gain	2	27	*	1-9999	None
Integral Time constant	2	29	1	0-999	0.1 Seconds
Derivative Time constant	2	31	1	0-999	0.1 Seconds
Rise to Soak Time	2	33	*	0-35999	Seconds
Soak Power	2	35	1	0-999	0.1%
Soak Time	2	37	*	0-35999	Seconds
Rise to Predeposit Time	2	39	*	0-35999	Seconds
Predeposit Power	2	41	1	0-999	0.1%
Predeposit Time	2	43	*	0-35999	Seconds
Rate Establish Error %	2	45	1	0-999	0.1 Å/sec
Deposition Rate #1	2	47	1	0-9999	0.1 Å/sec

## MDC-360 DEPOSITION CONTROLLER

Deposition Rate #2	2	49	1	0-9999	0.1 Å/sec
Deposition Rate #3	2	51	1	0-9999	0.1 Å/sec
Deposition Rate #4	2	53	1	0-9999	0.1 Å/sec
Deposition Rate #5	2	55	1	0-9999	0.1 Å/sec
Time Setpoint	2	57	*	0-35999	Seconds
Ramp to Feed Time	2	59	*	0-35999	Seconds
Feed Power	2	61	1	0-999	0.1%
Feed Time	2	63	*	0-35999	Seconds
Ramp to Idle Time	2	65	*	0-35999	Seconds
Idle Power	2	67	1	0-999	0.1%
Maximum Power	2	69	1	0-999	0.1%
Minimum Power	2	71	1	0-999	0.1%
Rate Deviation Attention	2	73	1	0-999	0.1%
Rate Deviation Alarm	2	75	1	0-999	0.1%
Rate Deviation Abort	2	77	1	0-999	0.1%
Sample Period	2	79	*	0-35999	Seconds
Backup Tooling Factor	2	81	1	100-4999	0.1%
Ramp Start Thick. #1	3	83	3	0-999900	Å
Ramp Stop Thick #1	3	86	3	0-999900	Å
Ramp Start Thick. #2	3	89	3	0-999900	Å
Ramp Stop Thick #2	3	92	3	0-999900	Å
Ramp Start Thick. #3	3	95	3	0-999900	Å
Ramp Stop Thick #3	3	98	3	0-999900	Å
Ramp Start Thick. #4	3	101	3	0-999900	Å
Ramp Stop Thick #4	3	104	3	0-999900	Å
Material password	4	107	*	N/A	ASCII
Total 111 bytes					

\* - Indicates decimal point position is not applicable.

Format: Header, Address, Instruction=6, Length=1, Material #(0-31), Checksum.

Example: To instruct the controller to send the parameter list for material #15 the computer would send:

Chr\$(255)+Chr\$(254)+Chr\$(1)+Chr\$(6)+Chr\$(1)+Chr\$(15)+Chr\$(233)

### 8. Receive a material (Code #7)

Instructs the controller to enter all the incoming material parameters for material # *n* into memory. The parameters must be in the same order and format as the above material parameter list.

Format: Header, Address, Instruction=7, Length=111, 1 byte, Material# (0-31), 110 bytes parameter data, Checksum.

### 9. Send material list (Code #8)

Instructs the controller to send a list of all material names in the order that they are stored in the controller. The material list consists of 32 10 character material names.

## MDC-360 DEPOSITION CONTROLLER

---

Example: To instruct the controller to send the material list the computer would send:

Chr\$(255)+Chr\$(254)+Chr\$(1)+Chr\$(8)+Chr\$(0)+Chr\$(247)

Since the MDC's message length is limited to 249 bytes, the controller will return the material list in two messages. The first message will contain material names 1-16 and the second message will contain material names 17-32.

### 10. Send number of undefined layers (Code #9)

Instructs the controller to send the number of undefined layers to the host computer.

Format: Header, Address, Instruction=9, Length=0, Checksum.

Example: Send number of undefined layers instruction:

Chr\$(255)+Chr\$(254)+Chr\$(1)+Chr\$(9)+Chr\$(0)+Chr\$(246)

Controller will return a message with the following format:

Header, Address, Instruction=9, Length=2, #Lyrs(2 bytes), Checksum.

### 11. Send process (Code #10)

Instructs the controller to send all the process parameters for process# n to the host computer. A description of the process parameter list is as follows:

Parameter Name	Length (bytes)	Decimal Pt. Position	Range	Units
Process #	1	*	(0-98)	None
Process name	12	*	Characters	None
Edit Password	4	*	Characters	None
View/Run Password	4	*	Characters	None
Number of Layers	2	*	(0-998)	None
Total 23 bytes				

All of the layer data for process #n will follow the above message. Since the MDC-360's message length is limited to 249 bytes, the controller will send the layer data in from one up to 17 separate messages depending on the number of layers in the process. Each message will contain from one to 60 layers. For example, if the process contains 250 layers, the controller will send the layer data in five messages. The first four message will have 60 layers and the last message will have 10 layers. The format of the layer messages is as follows:

Parameter Name	Length (bytes)	Decimal Pt. Position	Range	Units
Message Number	1	*	(1-17)	None
Layer # n Thickness	3	3	(0-999900)	Å
Layer # n Material #	1	*	(0-31)	None

## MDC-360 DEPOSITION CONTROLLER

---

The message number is included as a safeguard to insure that the all messages are received and are in order.

Example: To instruct the controller to send the process parameters for process #15 the computer would send:

Chr\$(255)+Chr\$(254)+Chr\$(1)+Chr\$(10)+Chr\$(1)+Chr\$(15)+Chr\$(229)

### 12. Receive process (Code #11)

Instructs the controller to enter the incoming parameters of process # *n* into memory. A description of the process parameter list is as follows:

Parameter Name	Length (bytes)	Decimal Pt. Position	Range	Units
Process #	1	*	(0-98)	None
Process Name	12	*	Character	None
Edit Password	4	*	Character	None
View/Run Password	4	*	Character	None
Total 21 bytes				

Format: Header, Address, Instruction=11, Length=21, 1 byte process#(0-98), 12 byte Process name(ASCII), 4 byte Edit Password, 4 byte View/Run Password, Checksum.

To modify process layers you must use the insert, replace, and delete process layer instructions.

### 13. Delete process (Code #12)

Instructs the controller to delete process# *n* and its associated layers.

Example: To instruct the controller to delete process# 15 the computer would send:

Chr\$(255)+Chr\$(254)+Chr\$(1)+Chr\$(12)+Chr\$(1)+Chr\$(15)+Chr\$(227)

### 14. Send process layer (Code #13)

Instructs the controller to send the process layer parameters for process # *n* layer # *y* to the host computer. A description of the process layer parameter list is as follows:

Parameter Name	Length (bytes)	Decimal Pt. Position	Range	Units
Process #	1	*	(0-98)	None
Layer #	2	*	(0-998)	None
Layer # <i>n</i> Thickness	3	3	(0-999900)	Å
Layer # <i>n</i> Material #	1	*	(0-31)	None
Total 7 bytes				

Format: Header, Address, Instruction=13, Length=3, 1 byte Process #, 2 byte Layer #, Checksum.

## MDC-360 DEPOSITION CONTROLLER

---

Example: To instruct the controller to send the process layer parameters for process #15 layer #5 the computer would send:

Chr\$(255)+Chr\$(254)+Chr\$(1)+Chr\$(13)+Chr\$(3)+Chr\$(15)+Chr\$(0)+Chr\$(5)+ Chr\$(219)

### 15. Insert process layer (Code #14)

Instructs the controller to insert the incoming layer parameters of process # *n* in front of layer # *y* adding the layer to the process. A description of the insert process layer parameter list is as follows:

Parameter Name	Length (bytes)	Decimal Pt. Position	Range	Units
Process #	1	*	(0-98)	None
Layer #	2	*	(0-998)	None
Layer # <i>n</i> Thickness	3	3	(0-999900)	Å
Layer # <i>n</i> Material #	1	*	(0-31)	None
Total 7 bytes				

If all of the layers are defined then the controller will respond with and insufficient layer space error.

### 16. Replace process layer (Code #15)

Instructs the controller to enter the incoming process layer parameters into process # *n* layer # *y*. A description of the process layer parameter list is given above.

Writing a layer to an undefined process results in an error. To define a process use the Receive Process instruction.

### 17. Delete process layer (Code #16)

Instructs the controller to delete later # *y* from process # *n*.

Format: Header, Address, Instruction=16, Length=3, 1 byte Process #(0-98), 2 byte Layer #(0-998), Checksum.

### 18. Send process list (Code #17)

Instructs the controller to send all process names in the order that they are stored in the controller. The process list consists of 99 12 character process names.

Example: To instruct the controller to send the process list the computer would send:

Chr\$(255)+Chr\$(254)+Chr\$(1)+Chr\$(17)+Chr\$(0)+Chr\$(238)

Since the MDC's message length is limited to 249 bytes, the controller will send the process names in five separate messages. The first four messages will each contain 20 names and the last message will contain 19 names.

### 19. Send source setup (Code #18)

Instructs the controller to send the source setup parameter list for all sources. A description of the source parameter list is as follows:

## MDC-360 DEPOSITION CONTROLLER

Parameter Name	Length (bytes)	Decimal Pt. Position	Range	Units
Number of Pockets	1	*	(1-8)	None
Shutter Relay Type	1	*	44=Normally open, 45=Normally closed, 46=None	None
Control	1	*	68=Direct, 69=BCD, 70=Indiv, 71=Manual	None
Drive	1	*	60=Up, 61=Down, 62=Fast, 63=Inline, 64=Sngl Step, 65=Dbl Step	None
Feedback input type	1	*	8 =Individual, 9=BCD, 10=Single Home, 11=In Position, 12=No Feedback	
Rotator Delay	1	*	(0-99)	seconds
Source voltage range	1	*	(16=2.5V, 17=5.0V, 18=10V)	Volts
Shutter Delay	2	*	(0-99) LSByte first	.1 sec
Total		9	bytes	

There are a total of four sources with 9 bytes per source for a total of 36 bytes. All 36 bytes are sent in the same message starting with source #1.

Example: To instruct the controller to send the source setup parameter list the computer would send:

Chr\$(255)+Chr\$(254)+Chr\$(1)+Chr\$(18)+Chr\$(0)+Chr\$(237)

### 20. Receive source setup (Code #19)

Instructs the controller to enter the incoming source setup parameters into memory. A description of the source setup parameter list is given above.

### 21. Send sensor setup (Code #20)

Instructs the controller to send the sensor setup parameter list for all sensors. A description of the sensor parameter list is as follows:

Parameter Name	Length (bytes)	Decimal Pt. Position	Range	Units
Number of crystals	1	*	(1-8)	None
Shutter Relay Type	1	*	44=Normally open, 45=Normally closed,	None

## MDC-360 DEPOSITION CONTROLLER

			46=None, 47=Dual	
Control	1	*	68=Direct, 69=BCD, 70=Indiv, 71=Manual	None
Drive	1	*	60=Up, 61=Down, 62=Fast, 63=Inline, 64=Sngl Step, 65=Dbl Step	None
Feedback input type	1	*	8 =Individual, 9=BCD, 10=Single Home, 11=In Position, 12=No Feedback	
Rotator Delay	1	*	(0-99)	seconds
Total		6	bytes	

There are a total of four sensors with 6 bytes per sensor for a total of 24 bytes. All 24 bytes are sent in the same message starting with sensor #1.

Example: To instruct the controller to send the sensor setup parameter list the computer would send:

Chr\$(255)+Chr\$(254)+Chr\$(1)+Chr\$(20)+Chr\$(0)+Chr\$(235)

### 22. Receive sensor setup (Code #21)

Instructs the controller to enter the incoming sensor setup parameters into memory. A description of the sensor setup parameter list is given above.

### 23. Send Input setup (Code #22)

Instructs the controller to send the Input parameter list for Input #n. A description of the Input parameter list is as follows:

Parameter Name	Length (bytes)	Allowable Range
Input #	1	(0-15)
Type	1	0,255
Name	16	All ASCII Characters
I/O Card#	1	1-2
Input True Level	0	Bit 7 of Card# (0 = Low, 1=High)
Input Pin#	1	30-37
Total 20 bytes		

## MDC-360 DEPOSITION CONTROLLER

---

The Type parameter defines whether the input is undefined, user defined, or internal. 0=Undefined, 255=user defined. All other types are internal and are only created by the MDC for source pocket and sensor crystal position control. When clearing an input you must set the type=0. When defining an input you must set the type=255. Internal types can only be set by the MDC.

Please note that bit 7 of the Input Card# byte represents the Input's True level. If bit 7 is set then the input is High level true. Or, if bit 7 is not set then the input is Low level true.

Format: Header, Instruction=22, Length=1, Input #(0-15), Checksum

Example: To instruct the controller to send the I/O setup parameter list for I/O #15 the computer would send:

Chr\$(255)+Chr\$(254)+Chr\$(1)+Chr\$(22)+Chr\$(1)+Chr\$(14)+Chr\$(218)

### 24. Receive Input setup (Code #23)

Instructs the controller to enter the incoming Input parameters for Input #n into memory. A description of the Input parameter list is given above.

Format: Header, Address, Instruction=23, Length=20, Input #(0-15), 1 byte Type, 16 byte Name, 1 byte Card#, 1 byte Pin#, Checksum

### 25. Send Output setup (Code #24)

Instructs the controller to send the Output parameter list for Output #n. A description of the Output parameter list is as follows:

Parameter Name	Length (bytes)	Allowable Range
Output #	1	(0-15)
Type	1	0,255
Name	16	All ASCII Characters
Condition String	24	!   & ( )
I/O Card#	1	1-2
Output Pin#	1	2-9
Total 44 bytes		

The Type parameter defines whether the output is undefined, user defined, or internal. 0=Undefined, 255=user defined. All other types are internal and are only created by the MDC for source pocket and sensor crystal position control. When clearing an output you must set the type=0. When defining an output you must set the type=255. Internal types can only be set by the MDC.

The condition string is described in the program I/O section of the manual. The allowable characters are ! | & ( ). The individual conditions are represented by numbers. The conditions are either 1, 2, or 3 bytes each. The first byte is the condition number. The second and third byte, if any, are the sub-condition number. The allowable conditions are listed in the following table:

## MDC-360 DEPOSITION CONTROLLER

Condition Name	Condition Number	Sub-condition Range
Controller State	128	0-25
Input	129	0-15
Process	130	0-98
Material	131	0-31
Sensor	132	1-4
Crystal	133	1-8
Source	134	1-4
Pocket	135	1-8
Layer	136	1-999, two bytes, MSByte first
Abort	137	Not Used
Halt	138	Not Used
Hold	139	Not Used
Time Power	140	Not Used
Ready	141	Not Used
In Process	142	Not Used
Simulate	143	Not Used
Time Setpoint	144	Not Used
Last Layer	145	Not Used
Crystal Failure	146	Not Used
Crystal Marginal	147	Not Used
Min Rate&Max Pwr	148	Not Used
Max Rate&Min Pwr	149	Not Used
Rate Dev. Alarm	150	Not Used
Rate Establish Error	151	Not Used
Source Fault	152	Not Used
Sensor Fault	153	Not Used
Rate Deviation Alert	154	Not Used
Max Power Alert	155	Not Used
Min Power Alert	156	Not Used
Rate Deviation Attention	157	Not Used
Max Power Attention	158	Not Used
Min Power Attention	159	Not Used

All condition strings must be terminated with a null (zero).

Format: Header, Instruction=24, Length=1, Output #(0-15), Checksum

Example: To instruct the controller to send the Output setup parameter list for Output #15 the computer would send:

Chr\$(255)+Chr\$(254)+Chr\$(1)+Chr\$(24)+Chr\$(1)+Chr\$(14)+Chr\$(216)

### 26. Receive Output setup (Code #25)

Instructs the controller to enter the incoming Output parameters for Output #n into memory. A description of the Output parameter list is given above.

## MDC-360 DEPOSITION CONTROLLER

---

Format: Header, Address, Instruction=25, Length=44, Output #(0-15), 1 byte Type, 16 byte Name, 24 byte Condition string, 1 byte Card#, 1 byte pin#, Checksum

### 27. Send Action setup (Code #26)

Instructs the controller to send the Action parameter list for Action #n. A description of the Action parameter list is as follows:

Parameter Name	Length (bytes)	Allowable Range
Action #	1	(0-15)
Action Type	1	(0-20)
Condition String	24	!   & ( )
Total 26 bytes		

Format: Header, Instruction=26, Length=1, Action #(0-15), Checksum

The action type defines the action that will be taken when the condition is evaluated as true. The following table contains the list of possible actions.

Action Name	Action Type
No Action	0
Manual Power	1
Zero Thickness	2
Reset Process	3
Abort Process	4
Halt Process	5
Terminate Deposit	6
Hold In State	7
Step From State	8
Sound Attention	9
Sound Alert	10
Sound Alarm	11
Start Process	12
Select Process 1	13
Select Process 2	14
Select Process 3	15
Select Process 4	16
Select Process 5	17
Select Process 6	18
Select Process 7	19
Select Process 8	20
Switch Crystals	21

Example: To instruct the controller to send the Action setup parameter list for Action #14 the computer would send:

Chr\$(255)+Chr\$(254)+Chr\$(1)+Chr\$(26)+Chr\$(1)+Chr\$(14)+Chr\$(214)

**MDC-360 DEPOSITION CONTROLLER**

---

**28. Receive Action setup (Code #27)**

Instructs the controller to enter the incoming Action parameters for Action #n into memory. A description of the Action parameter list is given above.

Format: Header, Address, Instruction=27, Length=26, Action #(0-15), 1 byte Action Type, 24 byte condition, Checksum

**29. Send controller status (Code #28)**

Instructs the controller to send the controller status data list. A description of the controller status data list is as follows:

Parameter Name	Length (bytes)	Range
Controller state	1	0 = Process ready 1 = Start layer 2 = Change pocket 3 = Change crystal 4 = Layer ready 5 = Soak rise 6 = Soak hold 7 = Rise to Predeposit 8 = Predeposit hold 9 = Establish rate 10 = Shutter Delay 11 = Deposit #1 12 = Rate ramp #1 13 = Deposit #2 14 = Rate ramp #2 15 = Deposit #3 16 = Rate ramp #3 17 = Deposit #3 18 = Rate ramp #4 19 = Deposit #5 20 = Ramp to feed 21 = Feed hold 22 = Ramp to idle 23 = Layer complete 24 = Process complete 25 = Process resume
Abort Process Errors	1	bit 6 = Max Rate&Min Pwr bit 7 = Min Rate&Max Pwr
Alarm 1 Errors	1	bit 0 = Action Setup Corrupted bit 1 = Output Setup Corrupted bit 2 = Input Setup Corrupted bit 3 = Crystal Fail, Process Halted bit 4 = Rate Establish Error bit 5 = Active Layer Corrupted bit 6 = Active Process Corrupted

## MDC-360 DEPOSITION CONTROLLER

		bit 7 = System Setup Corrupted
Alarm 2 Errors	1	bit 3 = Sound Alarm Action bit 4 = Rate Deviation Alarm bit 5 = Crystal Fail, Time Power Mode bit 6 = Sensor Fault bit 7 = Source Fault
Alert Errors	1	bit 3 = Sound Alert Action bit 4 = Minimum Power Alert bit 5 = Maximum Power Alert bit 6 = Rate Deviation Alert bit 7 = Crystal Marginal&Deposit
Attention 1 Errors	1	bit 0 = Process Complete bit 1 = Minimum Power Attention bit 2 = Maximum Power Attention bit 3 = Rate Deviation Attention bit 4 = Crystal Marginal&!In Process bit 5 = Crystal Fail&! In Process bit 6 = Crystal Marginal&In Process, Switch bit 7 = Crystal Fail&In Process, Switch
Attention 2 Errors	1	bit 3 = Manual Crystal Change bit 4 = Resume Process bit 5 = Sound Attention bit 6 = Manual Pocket Change bit 7 = Pause on Layer Complete
Discrete Input Register 1	1	bit 0 = Input #1, ... ( 0=False, 1=True)
Discrete Input Register 2	1	bit 0 = Input #9, ... ( 0=False, 1=True)
Discrete Output Register 1	1	bit 0 = Output #1, ... ( 0=False, 1=True)
Discrete Output Register 2	1	bit 0 = Output #9, ... ( 0=False, 1=True)
Controller Status 1	1	bit 0 = Ready Mode bit 1 = Manual Mode bit 2 = Time Power Mode bit 3 = Hold Mode bit 4 = Halt Mode bit 5 = Abort Mode bit 6 = Power Control Mode bit 7 = In Process
Controller Status 2	1	bit 0 = Resume Process bit 1 = Simulate Mode bit 5 = Material Time Setpoint bit 6 = Backup Sensor Active bit 7 = Last Layer Of Process
Source #1 Pocket Position	1	(1-8)
Source #2 Pocket	1	(1-8)

## MDC-360 DEPOSITION CONTROLLER

Position		
Source #3 Pocket Position	1	(1-8)
Source #4 Pocket Position	1	(1-8)
Source #1 Power	2	(0-4000), Power=99.9%*N/4000
Source #2 Power	2	(0-4000), Power=99.9%*N/4000
Source #3 Power	2	(0-4000), Power=99.9%*N/4000
Source #4 Power	2	(0-4000), Power=99.9%*N/4000
Sensor #1 Crystal Position	1	(1-8)
Sensor #2 Crystal Position	1	(1-8)
Sensor #3 Crystal Position	1	(1-8)
Sensor #4 Crystal Position	1	(1-8)
Sensor #1 Crystal Health	1	(0-99)%
Sensor #2 Crystal Health	1	(0-99)%
Sensor #3 Crystal Health	1	(0-99)%
Sensor #4 Crystal Health	1	(0-99)%
Total 33 bytes		

Format: Header, Address Instruction=28, Length=0, Checksum

Example: To instruct the controller to send the controller status the computer would send:

Chr\$(255)+Chr\$(254)+Chr\$(1)+Chr\$(28)+Chr\$(0)+Chr\$(227)

### 30. Start process (Code #29)

Instructs the controller to start process # *n* from starting layer # *x*.

Format: Header, Address, Instruction=29, Length=3, Process #(0-98) 1byte, Starting layer #(1-999) 2 bytes, Checksum.

Example: To instruct the controller to start process # 5 on layer # 10 the computer would send:

Chr\$(255)+Chr\$(254)+Chr\$(1)+Chr\$(29)+Chr\$(3)+Chr\$(4)+Chr\$(0)+Chr\$(9)+Chr\$(210)

### 31. Send run-time values (Code #30)

Instructs the controller to send the run-time value list. A description of the run-time

value list is as follows:

Value Name	Length (bytes)	Format	Units
------------	----------------	--------	-------

## MDC-360 DEPOSITION CONTROLLER

---

Power	4	String	%
Thickness	5	String	KÅ
Deposition rate	4	String	Å/sec
Time to go	7	String	Seconds
Crystal health	2	String	%
Layer number	3	String	None
Rate deviation	4	String	%
Active process number	1	BCD (0-98)	
Active material number	1	BCD (0-31)	
Active sensor number	1	BCD (1-4)	
Active crystal number	1	BCD (1-8)	
Active source number	1	BCD (1-4)	
Active pocket number	1	BCD (1-8)	
Total 35 bytes			

The string values are in ASCII format including decimal points or colons.

Example: To instruct the controller to send the run-time value list the computer would send:

Chr\$(255)+Chr\$(254)+Chr\$(1)+Chr\$(30)+Chr\$(0)+Chr\$(225)

### 32. Initiate Automatic Data Logging (Code #31)

This operation allows the computer to setup the MDC-360 to automatically output selected values to the RS232 port every 100 milliseconds. The values sent are determined by the bit value of the message byte in the data logging instruction message.

Byte #	Bit #	Description	Length(bytes)	Format	Units
1	0	Power	4	String	%
	1	Thickness	5	String	KÅ
	2	Deposition rate	4	String	Å/sec
	3	Time to go	7	String	Seconds
	4	Crystal health	2	String	%
	5	Layer number	3	String	None
	6	Rate deviation	4	String	%

All values are in ASCII format including decimal points or colons.

For example, to instruct the MDC to output rate and power the computer would send the following message:

Chr\$(255)+Chr\$(254)+Chr\$(1)+Chr\$(31)+Chr\$(1)+Chr\$(5)+Chr\$(218)

Data logging is stopped by sending the following message:

Chr\$(255)+Chr\$(254)+Chr\$(1)+Chr\$(31)+Chr\$(0)+Chr\$(224)

### 33. Internal Command

## MDC-360 DEPOSITION CONTROLLER

---

### 34. Set Active Source Power (Code #33)

Instructs the controller to enter the incoming source power value into the active source power. This command only works if the controller is in the manual power control mode. A description of the manual power parameter list is as follows:

Parameter Name	Length (bytes)	Allowable Range
Source Power	2	(0-999) units are 0.1%
Total 2 bytes		

For example, to set the source power to 50% the computer would send the following message:

Chr\$(255)+Chr\$(254)+Chr\$(1)+Chr\$(33)+Chr\$(2)+Chr\$(1)+Chr\$(244)+  
Chr\$(231)

### 35. Internal Command

### 36. Internal Command

### 37. Send Process Log Directory (Code #36)

Instructs the controller to send the process log directory to the host computer. This command is only valid on controllers with the internal data log storage option installed. The process log directory consists of 16 individual process logs. The data format of a process log is listed in the following table:

Parameter Name	Length (bytes)	Allowable Range
Process Log Name	12	All ASCII Characters
Process Run Number	2	(1-9999)
Starting Time	3	(00:00:00-23:59:59) HH:MM:SS
Starting Date	3	(01/01/00-12/31/99) MM:DD:YY
Completion Time	3	(00:00:00-23:59:59) HH:MM:SS
Completion Status	1	(0=Normal, 1=Aborted, 2=Running, 3=Overrun)
Data Points/Minute	1	(38=30ppm, 39=60ppm, 40=120ppm, 41=300ppm, 42=600ppm)
Starting Layer Number	2	(0-999)
Ending Layer Number	2	(0-999)
Total 29 bytes		

The time and date data is in an unpacked BCD format. The four most significant bits of a byte is the first digit's value and the four least significant bits is the second digit's value. For example, a byte value of 41 decimal equates to a first

## MDC-360 DEPOSITION CONTROLLER

---

digit of 2 and a second digit of 9. The 2 comes from the four MSbits and the 9 comes from the four LSbits of the byte.

The process run number and the starting and ending layer numbers are in the normal MSbyte first BCD format.

If the first byte of the process name of any process log is equal to 255 then that log is considered blank.

Since the MDC's message length is limited to 249 bytes, the controller will send the process log directory data in two separate 232 byte messages. The first message will contain the first eight logs and the second message will contain the last eight logs.

Example: To instruct the controller to send the process log directory the computer would send:

`Chr$(255)+Chr$(254)+Chr$(1)+Chr$(36)+Chr$(0)+Chr$(219)`

### 38. Send Process Log Data (Code #37)

Instructs the controller to send the process log data for log #n and layer #y to the host computer. This command is only valid on controllers with the internal data log storage option installed. The process log number can range from 1-16 and the layer number can range from 1 to 999. Trying to read an empty process log or a layer that doesn't exist will result in parameter out of range error. The layer data for a process log is sent in two message types. The first type holds the layer material name and the number of data point sets stored. The second type holds the data point set data. The following table shows the data format of the layer material message type:

Parameter Name	Length (bytes)	Allowable Range
Layer Material Name	10	All ASCII Characters
Number of Data Point Sets	2	(1-27,000)
Total 12 bytes		

Following the above message will be a number of messages containing the data point set data. The following table shows the data format of the data point set message type for one data point set:

## MDC-360 DEPOSITION CONTROLLER

---

Parameter Name	Length (bytes)	Units
Message Number	2	1-1125
Thickness	3	Angstroms
Rate	3	0.1 Angstroms/second
Power	2	0.1 %
Rate Deviation	2	0.1 %
Total 12-242 bytes		

Since the MDC's message length is limited to 249 bytes, a data point set message will contain up to 24 data point sets for a total of 242 bytes. The controller will send as many messages as needed to complete the process log layer. To determine the number of messages to expect, you just divide the number of data point sets by 24. And, if there are any left over, then add one more to the result. Very long layers can result in over a 1000 messages which will take up to two minutes to send. This last message will contain the remaining data point sets to complete the layer. A message number is included in each message to ensure that all messages are received and are in order.

Format: Header, Address=1, Instruction=37, Length=3, 1 byte Log#(1-16), 2 byte Layer#(1-999), Checksum

Example: To instruct the controller to send the layer 1 of process log 5 the computer would send:

Chr\$(255)+Chr\$(254)+Chr\$(1)+Chr\$(37)+Chr\$(3)+Chr\$(5)+Chr\$(0)+  
Chr\$(1)+Chr\$(209)

### 39. Remote activation of controller (Code #38)

This instruction initiates a remote action. The possible actions are shown in the following table:

Remote Action Code	Description	Action Trigger Type
0	Sound Alarm Action	Momentary
1	Sound Alert Action	Momentary
2	Sound Attention Action	Momentary
3	Step From State Action	One Shot
6	Clear Hold in State Action	Continuous
5	Set Hold in State Action	Continuous
6	Terminate Deposit Action	One Shot
7	Halt Process Action	One Shot
8	Switch Crystals	One Shot

All the momentary actions trigger the action for a 100 millisecond period for each message received. The one shot actions trigger the action once for each message received. For example, sending one step from state message would cause the controller to step into the next state one time. The continuous actions trigger that

## MDC-360 DEPOSITION CONTROLLER

---

action indefinitely. So the set hold in state action will cause the controller to hold in the current state until the clear hold in state action is received and the exit state condition is met.

Format: Header, Address=1, Instruction=38, Length=1, Action Code (0-8), Checksum

Example: To initiate a terminate deposit action the computer would send:

Chr\$(255)+Chr\$(254)+Chr\$(1)+Chr\$(38)+Chr\$(1)+Chr\$(6)+Chr\$(210)

### 40. Send run-time values (Code #39)

Instructs the controller to send one run-time value base on the value# received.

Format: Header, Address, Instruction=39, Length=1, value #(0-12) 1byte, Checksum.

A description of the run-time value list is as follows:

Value#	Value Name	Length (bytes)	Format	Units
0	Power	4	String	%
1	Thickness	5	String	KÅ
2	Deposition rate	4	String	Å/sec
3	Time to go	7	String	Seconds
4	Crystal health	2	String	%
5	Layer number	3	String	None
6	Rate deviation	4	String	%
7	Active process number	1	BCD (0-98)	
8	Active material number	1	BCD (0-31)	
9	Active sensor number	1	BCD (1-4)	
10	Active crystal number	1	BCD (1-8)	
11	Active source number	1	BCD (1-4)	
12	Active pocket number	1	BCD (1-8)	
13	Sensor #1 Health	1	BCD (0-99, 255=Failed)	
14	Sensor #2 Health	1	BCD (0-99, 255=Failed)	
15	Sensor #3 Health	1	BCD (0-99, 255=Failed)	
16	Sensor #4 Health	1	BCD (0-99, 255=Failed)	

The string values are in ASCII format including decimal points or colons.

Example: To instruct the controller to send the layer number value, the computer would send:

Chr\$(255)+Chr\$(254)+Chr\$(1)+Chr\$(39)+Chr\$(1)+Chr\$(5)+Chr\$(210)

The 360 will return the layer number as a three byte string.

### 41. Enable/Disable the front panel keyboard (Code #40)

## MDC-360 DEPOSITION CONTROLLER

---

Instructs the controller to either enable or disable the MDC-360's front panel keys based on the value received. A value of 255 disables the keys. Any other value will enable the keys.

Format: Header, Address, Instruction=40, Length=1, value #(0,255) 1byte, Checksum.







## 12. REPAIR AND MAINTENANCE

### 12.1 HANDLING PRECAUTIONS

Integrated Circuits (I.C.'s) can be damaged by static discharge into their inputs. This static discharge is the same phenomenon that produces the unpleasant shock when one grabs a door knob after walking across a carpet. The likelihood of static buildup is proportional to the dryness of the air and can be particularly troublesome in cold, dry climates, or hot desert climates.

In order to minimize the chance of discharging body charge into the I.C. inputs, always handle circuit boards by the edge, avoiding contact with the connector area. When moving a board from one surface or work area to another surface or work area, always personally touch the new surface or location before laying down or inserting the board so that you, the board, and the surface, or equipment, are all at the same potential. It is wise in dry climates to minimize the amount of movement when handling or replacing I.C.'s in circuit boards. When handing a circuit board or I.C. to another person, always touch the person first.

Wood or paper surfaces are the most forgiving surfaces to work on. Plastic should be avoided. Metal is O.K. as long as the metal is always touched with the hand prior to laying down the I.C.'s or circuit boards.

P.C. boards or I.C.'s should never be placed in plastic bags unless they are of the conductive plastic type intended for this use. These bags are typically black or pink and are normally labeled as conductive or anti-static. If no conductive plastic bags are available, boards or I.C.'s can be wrapped in paper, and then placed in plastic bags or shipping bags.

If the above precautions are observed, the chance of damage will be minimal and no problems should be encountered.

### 12.2 MAINTENANCE PHILOSOPHY

The MDC-360 was designed around a maintenance philosophy of board replacement. Field repair at the component level is not recommended and indeed can void the warranty. The following sections are intended primarily as an aid in understanding the operation of the MDC-360 and to help in isolating problems to the board level.

All electronic components, with the exception of the power supply transformer, are mounted on plug-in assemblies for ease of removal and replacement. The circuitry is partitioned among plug-in modules on a functional basis to make fault isolation to the plug-in assembly level as straightforward as possible.

Most problems can be diagnosed to the board level without external test equipment and verified by simple board replacement.

## MDC-360 DEPOSITION CONTROLLER

### CAUTION

**Remove AC line power before disassembling the controller to avoid electrical shock.**

### 12.3 TROUBLE SHOOTING AIDS

Symptom	Possible Cause
Unit blows line fuse.	<ul style="list-style-type: none"> <li>a) Line voltage selection card is not installed to agree with line voltage being used.</li> <li>b) Incorrect fuse size.</li> <li>c) Shorted rectifiers in power supply area.</li> <li>d) Shorted transformer or filter capacitor.</li> </ul>
Front Panel display never illuminates.	<ul style="list-style-type: none"> <li>a) Blown fuse.</li> <li>b) Faulty clock generator (High Speed Counter board)</li> </ul>
Parameter/Status display shows a blank blue screen	<ul style="list-style-type: none"> <li>a) Contrast level is set too low.</li> <li>b) Bad Front Panel Logic board.</li> <li>c) Bad LCD display.</li> </ul>
“Crystal Failure” message flashes with selected sensor properly connected.	<ul style="list-style-type: none"> <li>a) Defective cable or cables.</li> <li>b) Defective or overloaded sensor crystal.</li> <li>c) Oscillator unit connected in the wrong direction.</li> <li>d) Bad Oscillator unit.</li> </ul>
No control voltage while monitoring output of selected Source/Sensor bd.	<ul style="list-style-type: none"> <li>a) Cable/connector miswired or shorted. (Source/Sensor board)</li> <li>b) Bad Source/Sensor board.</li> </ul>
Front panel control keys non-functional.	<ul style="list-style-type: none"> <li>a) Defective membrane keys</li> <li>b) Bad Front Panel Logic board</li> </ul>
Unit does not retain programmed data in memory.	<ul style="list-style-type: none"> <li>a) “Power up” or “Power down” sequencing circuit malfunctioning.</li> <li>b) “RAM Power” switching circuit not functioning.</li> <li>c) Aged or defective batteries.</li> <li>d) Bad Main Processor board.</li> </ul>
The unit fails to activate externally controlled devices (Shutters, solenoids, etc.)	<ul style="list-style-type: none"> <li>a) Faulty Relay (Discrete I/O board)</li> <li>b) Bad Discrete I/O board.</li> </ul>
Unable to remotely control the unit via Discrete I/O inputs.	<ul style="list-style-type: none"> <li>a) Improperly wired cable/connector.</li> <li>b) Inputs not properly grounded.</li> <li>c) Bad Discrete I/O board.</li> </ul>
Unable to manually control the source	<ul style="list-style-type: none"> <li>a) Controller is not in Manual mode.</li> </ul>

## MDC-360 DEPOSITION CONTROLLER

---

power through the Remote Power Handset.	b) Controller is in Abort mode. c) Faulty Remote Power Handset. d) Bad connection from the Manual Control connector to the Main bd.
Faulty DAC outputs.	a) Improper DAC wiring. b) External recording device puts excessive load on the DAC.

For further assistance, call your supplier or Ferrotec GmbH +49(7022) 9270-0.

### 12.4 RETURNING THE MDC-360 TO THE FACTORY

If there is a need to return your controller to the factory, please call Ferrotec GmbH to obtain a Returned Merchandise Authorization Number (RMA#). This number is required prior to returning your controller to the factory. You are required to show this RMA number on your shipping document. It will help us track and ensure proper actions will be made to your controller.



13. APPENDIX A

Table 13-1 Source Control Cable Color Code - (4 pin Mini DIN)

Pin Number	Color	Signal
1	Black	Source 2 or 4 control
2	Green	Source 2 or 4 return
3	Red	Source 1 or 3 return
4	Brown or White ***	Source 1 or 3 control

\*\*\* Note: This color code varies depending on the manufacturer. It is coded BROWN in a 4-conductor cable and WHITE in a 7-conductor cable.

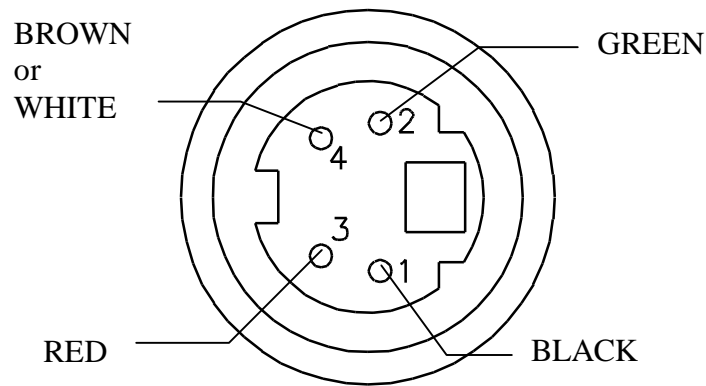

Figure 13-1 Plug pin out - Source cable connector

## MDC-360 DEPOSITION CONTROLLER

Table 13-2 DAC Cable Color Code - (7 pin Mini DIN)

Pin Number	Color	Signal
1	Black	DAC output #1
2	Green	DAC output #1 return
3	Red	DAC output #2
4	Brown	DAC output #2 return
5	Blue	Zero Scale
6	White	Full Scale
7	Yellow	Ground

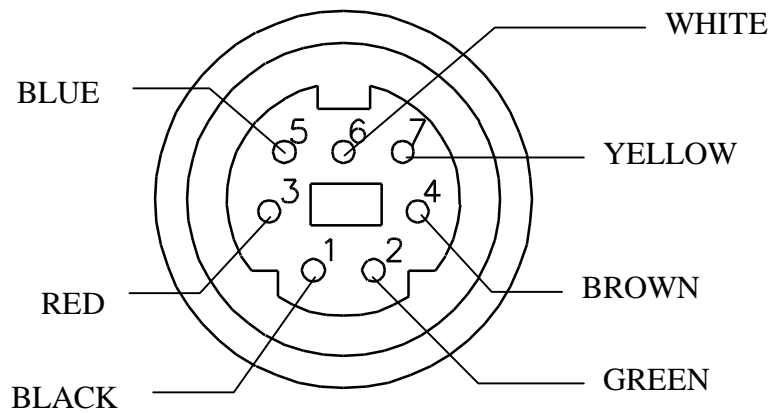

Figure 13-2 Plug pin out - DAC cable connector



## **14. APPENDIX B – PARAMETER TEMPLATES**

MDC-360 DEPOSITION CONTROLLER

14.1 MATERIAL

<b>Material Number</b>	
<b>Material Name</b>	
<b>Sensor #</b>	
<b>Crystal #</b>	
<b>Source #</b>	
<b>Pocket #</b>	
<b>Material Density</b>	
<b>Acoustic Impedance</b>	
<b>Tooling Factor</b>	
<b>Proportional gain</b>	
<b>Integral Time constant</b>	
<b>Derivative Time constant</b>	
<b>Rise to Soak Time</b>	
<b>Soak Power</b>	
<b>Soak Time</b>	
<b>Rise to Predeposit Time</b>	
<b>Predeposit Power</b>	
<b>Predeposit Time</b>	
<b>Rate Establish Time</b>	
<b>Rate Establish Error</b>	
<b>Deposition Rate 1</b>	
<b>Rate Ramp Start 1</b>	
<b>Rate Ramp Stop 1</b>	
<b>Deposition Rate 2</b>	
<b>Rate Ramp Start 2</b>	
<b>Rate Ramp Stop 2</b>	
<b>Deposition Rate 3</b>	
<b>Rate Ramp Start 3</b>	
<b>Rate Ramp Stop 3</b>	
<b>Deposition Rate 4</b>	
<b>Rate Ramp Start 4</b>	
<b>Rate Ramp Stop 4</b>	
<b>Deposition Rate 5</b>	
<b>Time Setpoint</b>	
<b>Ramp to Feed Time</b>	
<b>Feed Power</b>	
<b>Feed Time</b>	
<b>Ramp to Idle Time</b>	
<b>Idle Power</b>	

SYSTEM: \_\_\_\_\_ ENTERED BY: \_\_\_\_\_ APPROVED BY: \_\_\_\_\_ DATE: \_\_\_\_\_

**MDC-360 DEPOSITION CONTROLLER**

---

**MATERIAL CONT'D**

<b>Maximum Power</b>	
<b>Max Power Alarm Delay</b>	
<b>Minimum Power</b>	
<b>Rate Deviation Attention</b>	
<b>Rate Deviation Alarm</b>	
<b>Rate Deviation Abort</b>	
<b>Sample Dwell %</b>	
<b>Sample Period</b>	
<b>Crystal Fail</b>	
<b>Backup Sensor #</b>	
<b>Backup Crystal #</b>	
<b>Backup Tooling Factor</b>	
<b>Material Password</b>	

SYSTEM: \_\_\_\_\_ ENTERED BY: \_\_\_\_\_ APPROVED BY: \_\_\_\_\_ DATE: \_\_\_\_\_



## MDC-360 DEPOSITION CONTROLLER

---

### 14.3 DISPLAY SETUP

<b>Pause On Layer Complete</b>	<input type="checkbox"/> Yes	<input type="checkbox"/> No
<b>Display Negatives</b>	<input type="checkbox"/> Enabled	<input type="checkbox"/> Disabled
<b>Thickness Graph Scale</b>	<input type="checkbox"/> 2 Digit	<input type="checkbox"/> 3 Digit
<b>Time To Go Display</b>	<input type="checkbox"/> Estimated State <input type="checkbox"/> Elapsed Layer <input type="checkbox"/> Estimated Layer	<input type="checkbox"/> Elapsed Process <input type="checkbox"/> Elapsed State
<b>Rate Graph</b>	<input type="checkbox"/> Enabled	<input type="checkbox"/> Disabled
<b>Power Graph</b>	<input type="checkbox"/> Enabled	<input type="checkbox"/> Disabled
<b>Thickness Graph</b>	<input type="checkbox"/> Enabled	<input type="checkbox"/> Disabled
<b>Rate Dev. Graph</b>	<input type="checkbox"/> Enabled	<input type="checkbox"/> Disabled
<b>Source/Sensor Status</b>	<input type="checkbox"/> Enabled	<input type="checkbox"/> Disabled
<b>I/O Status</b>	<input type="checkbox"/> Enabled	<input type="checkbox"/> Disabled

SYSTEM: \_\_\_\_\_ ENTERED BY: \_\_\_\_\_ APPROVED BY: \_\_\_\_\_ DATE: \_\_\_\_\_

# MDC-360 DEPOSITION CONTROLLER

## 14.4 INPUTS

Input #	Input Name	True/Logic	Card #	Pin #	Return Pin #
1		<input type="checkbox"/> LOW <input type="checkbox"/> HIGH			
2		<input type="checkbox"/> LOW <input type="checkbox"/> HIGH			
3		<input type="checkbox"/> LOW <input type="checkbox"/> HIGH			
4		<input type="checkbox"/> LOW <input type="checkbox"/> HIGH			
5		<input type="checkbox"/> LOW <input type="checkbox"/> HIGH			
6		<input type="checkbox"/> LOW <input type="checkbox"/> HIGH			
7		<input type="checkbox"/> LOW <input type="checkbox"/> HIGH			
8		<input type="checkbox"/> LOW <input type="checkbox"/> HIGH			
9		<input type="checkbox"/> LOW <input type="checkbox"/> HIGH			
10		<input type="checkbox"/> LOW <input type="checkbox"/> HIGH			
11		<input type="checkbox"/> LOW <input type="checkbox"/> HIGH			
12		<input type="checkbox"/> LOW <input type="checkbox"/> HIGH			
13		<input type="checkbox"/> LOW <input type="checkbox"/> HIGH			
14		<input type="checkbox"/> LOW <input type="checkbox"/> HIGH			
15		<input type="checkbox"/> LOW <input type="checkbox"/> HIGH			
16		<input type="checkbox"/> LOW <input type="checkbox"/> HIGH			

SYSTEM: \_\_\_\_\_ ENTERED BY: \_\_\_\_\_ APPROVED BY: \_\_\_\_\_ DATE: \_\_\_\_\_

MDC-360 DEPOSITION CONTROLLER

---

14.5 OUTPUTS

Output #	Output Name	Conditions	Card #	Pin #	Return Pin #
1					
2					
3					
4					
5					
6					
7					
8					
9					
10					
11					
12					
13					
14					
15					
16					

SYSTEM: \_\_\_\_\_ ENTERED BY: \_\_\_\_\_ APPROVED BY: \_\_\_\_\_ DATE: \_\_\_\_\_

## MDC-360 DEPOSITION CONTROLLER

---

### 14.6 ACTIONS

Output #	Action Name	Conditions
1		
2		
3		
4		
5		
6		
7		
8		
9		
10		
11		
12		
13		
14		
15		
16		

SYSTEM: \_\_\_\_\_ ENTERED BY: \_\_\_\_\_ APPROVED BY: \_\_\_\_\_ DATE: \_\_\_\_\_

**MDC-360 DEPOSITION CONTROLLER**

---

**14.7 SENSOR SETUP**

<b>Sensor #</b>	<input type="checkbox"/> 1 <input type="checkbox"/> 2 <input type="checkbox"/> 3 <input type="checkbox"/> 4
<b>Number of Crystals</b>	<input type="checkbox"/> 1 <input type="checkbox"/> 2 <input type="checkbox"/> 3 <input type="checkbox"/> 4 <input type="checkbox"/> 5 <input type="checkbox"/> 6 <input type="checkbox"/> 7 <input type="checkbox"/> 8
<b>Shutter Relay Type</b>	<input type="checkbox"/> N.O. <input type="checkbox"/> N.C. <input type="checkbox"/> DUAL
<b>Control</b>	<input type="checkbox"/> MANUAL <input type="checkbox"/> DIRECT <input type="checkbox"/> BCD <input type="checkbox"/> INDIV.
<b>Drive</b>	<input type="checkbox"/> UP <input type="checkbox"/> DOWN <input type="checkbox"/> FAST <input type="checkbox"/> INLINE <input type="checkbox"/> SNGL STEP <input type="checkbox"/> DBL STEP
<b>Feedback Type</b>	<input type="checkbox"/> NO FEEDBACK <input type="checkbox"/> INDIVIDUAL <input type="checkbox"/> BCD <input type="checkbox"/> SINGLE HOME <input type="checkbox"/> IN POSITION
<b>Rotator Delay (sec)</b>	

**14.8 SOURCE SETUP**

<b>Source #</b>	<input type="checkbox"/> 1 <input type="checkbox"/> 2 <input type="checkbox"/> 3 <input type="checkbox"/> 4
<b>Number of Pockets</b>	<input type="checkbox"/> 1 <input type="checkbox"/> 2 <input type="checkbox"/> 3 <input type="checkbox"/> 4 <input type="checkbox"/> 5 <input type="checkbox"/> 6 <input type="checkbox"/> 7 <input type="checkbox"/> 8
<b>Shutter Relay Type</b>	<input type="checkbox"/> N.O. <input type="checkbox"/> N.C.
<b>Shutter Delay (sec)</b>	
<b>Control</b>	<input type="checkbox"/> MANUAL <input type="checkbox"/> DIRECT <input type="checkbox"/> BCD <input type="checkbox"/> INDIV.
<b>Drive</b>	<input type="checkbox"/> UP <input type="checkbox"/> DOWN <input type="checkbox"/> FAST <input type="checkbox"/> INLINE <input type="checkbox"/> SNGL STEP <input type="checkbox"/> DBL STEP
<b>Feedback Type</b>	<input type="checkbox"/> NO FEEDBACK <input type="checkbox"/> INDIVIDUAL <input type="checkbox"/> BCD <input type="checkbox"/> SINGLE HOME <input type="checkbox"/> IN POSITION
<b>Rotator Delay (sec)</b>	
<b>Source Voltage</b>	<input type="checkbox"/> 2.5V <input type="checkbox"/> 5V <input type="checkbox"/> 10V

SYSTEM: \_\_\_\_\_ ENTERED BY: \_\_\_\_\_ APPROVED BY: \_\_\_\_\_ DATE: \_\_\_\_\_

## MDC-360 DEPOSITION CONTROLLER

---

### 14.9 DAC SETUP

<b>DAC Output #1</b>	<input type="checkbox"/> Rate <input type="checkbox"/> Rate Dev. <input type="checkbox"/> Power <input type="checkbox"/> Thickness
<b>DAC Scale #1</b>	<input type="checkbox"/> 3 Digit <input type="checkbox"/> 2 Digit
<b>DAC Output #2</b>	<input type="checkbox"/> Rate <input type="checkbox"/> Rate Dev. <input type="checkbox"/> Power <input type="checkbox"/> Thickness
<b>DAC Scale #2</b>	<input type="checkbox"/> 3 Digit <input type="checkbox"/> 2 Digit

### 14.10 UTILITY SETUP

<b>Crystal Frequency</b>	<input type="checkbox"/> 2.5 <input type="checkbox"/> 3.0 <input type="checkbox"/> 5.0 <input type="checkbox"/> 6.0 <input type="checkbox"/> 9.0 <input type="checkbox"/> 10.0
<b>Simulate Mode</b>	<input type="checkbox"/> On <input type="checkbox"/> Off
<b>Interface Address (1-32)</b>	
<b>Attention Volume (0-10)</b>	
<b>Alert Volume (0-10)</b>	
<b>Alarm Volume (0-10)</b>	
<b>Data Points/Min (ppm)</b>	<input type="checkbox"/> 30 <input type="checkbox"/> 60 <input type="checkbox"/> 120 <input type="checkbox"/> 300 <input type="checkbox"/> 600

SYSTEM: \_\_\_\_\_ ENTERED BY: \_\_\_\_\_ APPROVED BY: \_\_\_\_\_ DATE: \_\_\_\_\_