

FOR SALES AND SERVICE PLEASE CALL:

PTB SALES T :: 626.334.0500  
service@ptbsales.com  
www.ptbsales.com

DATE SERVICED: \_\_\_\_\_

**VIEW OUR INVENTORY**

This Document has been  
**ARCHIVED**  
For reference use only  
Edwards Hi Vacuum International

**MODEL : 306\*  
310\* HIGH VACUUM BLOWERS**

**SERIAL NO.**

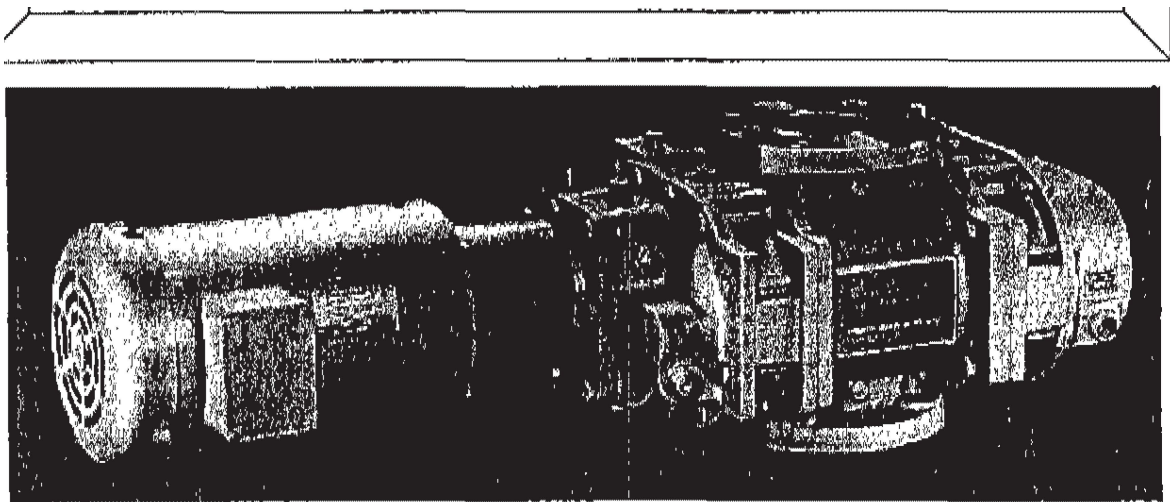

**\*IF YOU BLOWER HAS A -41 OR -42 MODEL NUMBER (EX. 306-041),  
YOUR BLOWER IS PREPARED FOR SPECIAL SERVICE USE. FOLLOW  
ALL PRECAUTIONS STATED HEREIN FOR SPECIAL SERVICE USE.\***

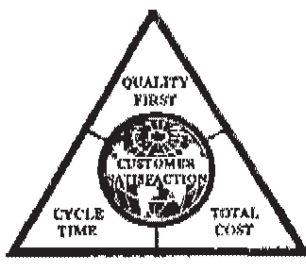

Copyright © 1994  
All Rights Reserved  
Revision 1.2  
4-94

DNV Certification, Inc.  
USA



DNV NSG  
The Netherlands  
Accredited by the RYA



ISO 9001  
REGISTERED FIRM

**NOTE:**

"THE INFORMATION HEREIN SHALL BE TREATED IN THE STRICTEST CONFIDENCE, AND SHALL NOT BE DISCLOSED TO ANY THIRD PARTY WITHOUT THE PRIOR WRITTEN PERMISSION OF

 **BOC EDWARDS**  
**Stokes Vacuum**

THIS INFORMATION SHALL BE USED SOLELY FOR THE PURPOSE FOR WHICH IT HAS BEEN SUPPLIED AND FOR NO OTHER PURPOSE WHATSOEVER."

**\*IF YOUR BLOWER  
HAS A -41 OR -42  
MODEL NUMBER  
(EX. 306-041)  
YOUR BLOWER IS  
PREPARED FOR  
SPECIAL SERVICE  
USE. FOLLOW ALL  
PRECAUTIONS  
STATED HEREIN.**

# **WARNING FOR SPECIAL SERVICE BLOWERS ONLY**

**This blower has been arranged for pumping oxygen.**

**Keep clean and free of hydrocarbons. Use only the oil specified in the blower manual for the blower.**

**Substitutes cannot be used.**

**Use of other oils or contamination with hydrocarbons can result in an explosion.**

# OPERATING INSTRUCTIONS

## TABLE OF CONTENTS

<b>Section</b>	<b>Page</b>
<b>1.0 DESCRIPTION</b>	
1.1 Principle of Operation	1-1
1.2 Maximum Allowable Operating Conditions	1-1
1.3 Lubricant	1-1
1.4 Booster Arrangements	1-2
<b>2.0 INSTALLATION</b>	
2.1 General	2-1
2.2 Belt Drive	2-1
2.3 Direct Drive	2-2
2.4 Oxygen Service	2-2
2.5 Cleaning	2-2
2.6 Lubrication	2-3
2.7 Lubrication Schedule	2-4
2.8 Lubrication Diagram - Vertical Flow	2-4
2.9 Lubrication Diagram - Horizontal Flow	2-5
<b>3.0 OPERATION</b>	
3.1 Operation	3-1
<b>4.0 SPECIFICATIONS AND PARTS LIST</b>	
<b>5.0 STOKES SUPPLEMENTARY DATA</b>	
Parts Ordering Information	
Stokes 2-Year Warranty	
Warranty and Field Service Policy	
Pumping Hazardous Gases Sheet	

## **SAFETY PRECAUTIONS**

For equipment covered specifically or indirectly in this instruction book, it is important that all personnel observe safety precautions to minimize the chances of injury. Among many considerations, the following should particularly be noted:

1. Pump casing and associated piping or accessories may, even under normal operating conditions, become hot enough to cause major skin burns on contact.
2. Internal and external rotating parts of the booster and driving equipment can produce serious physical injuries. Do not reach into any opening in the booster while it is operating, or while subject to accidental starting. Cover external moving parts with adequate guards.
3. Disconnect power before doing any work, and avoid bypassing or rendering inoperative any safety or protective devices.
4. If booster is operated with piping disconnected, place a strong coarse screen over the inlet.
5. Stay clear of open inlet piping (suction area) and the open discharge blast.
6. Stay clear of the blast from pressure relief valves and the suction area of vacuum relief valves.
7. Use proper care and good procedure in handling, lifting, installing, operating and maintaining the equipment.
8. Casing pressure must not exceed 25 psi (172 kpa) gauge. Do not pressurize vented cavities from an external source, nor restrict the vents.
9. When adding to or drawing oil from or otherwise servicing a blower which has been pumping toxic, flammable, explosive or other hazardous substances, observe appropriate precautions to avoid serious personal injury.

# **CAUTION**

**VACUUM BOOSTER IS  
SHIPPED WITH OIL IN  
SEPARATE  
CONTAINER.**

**BEFORE OPERATING, PUT THE  
REQUIRED AMOUNT OF OIL  
INTO THE THREE OIL  
RESERVOIRS PER  
INSTRUCTIONS UNDER  
LUBRICATION.**

**DO NOT FILL OIL RESERVOIRS  
UNTIL VACUUM BOOSTER IS  
MOUNTED IN ITS OPERATING  
LOCATION.**

## MODEL 306/310 BLOWER

### 1.0 DESCRIPTION

#### 1.1 PRINCIPLE OF OPERATION

Stokes Models 306 and 310 blowers are single stage positive displacement vacuum booster machines. The blower consists of two double lobe impellers that are mounted in parallel, and rotate in synchronous mesh in a one-piece cylinder. As gas enters the inlet port it fills a cavity exposed by rotation of the impellers, Fig. 1, position 1. The impellers continue to turn and trap a quantity of gas between the rotating impeller and blower casing, Fig. 1, position 2. Further rotation pushes the trapped volume around the cylinder and out the discharge port, Fig. 1, position 3.

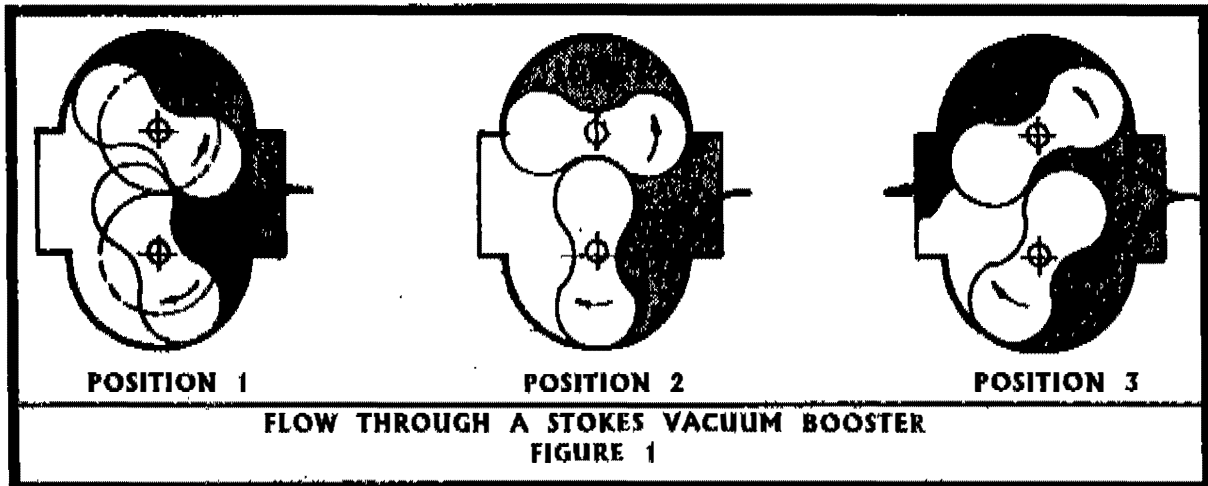

The high vacuum blowers covered in this manual are intended especially for use as a preceding stage of a vacuum pumping system with a suitable forepump or roughing pump that will allow the blower to operate satisfactorily within its pressure and temperature limits. It is not intended for duty as a positive pressure blower.

#### 1.2 MAXIMUM ALLOWABLE OPERATING CONDITIONS

MODEL		306	310
DISPLACEMENT*	CFM	125	400
		245	
PUMP SPEED RPM @	60 HZ	1800	3600
		3600	
MAX PRESSURE DIFFERENTIAL	TORR	380	380
TEMPERATURE RISE	DEG. F	275	275
	DEG. C	135	135
DISCHARGE TEMP	DEG. F	375	375
	DEG. C	191	191
DRIVE HP		5 HP MAX	

\* FOR OPERATION WITH DIRECT DRIVE @ 50 HZ., PUMP SPEED IS 5/6 OF THAT SHOWN FOR 60 HZ. IF UNIT IS BELT DRIVEN, PULLEY RATIO CAN BE CHANGED TO COMPENSATE.

**NOTE:                      MAXIMUM PRESSURE RISE, TEMPERATURE RISE AND HORSEPOWER DO NOT NECESSARILY COINCIDE. WHICHEVER LIMIT IS REACHED FIRST IS TO BE CONSIDERED THE LIMITING FACTOR.**



## MODEL 306/310 BLOWER

### 1.3

#### LUBRICANT

Lubricating oil is shipped in a separate container. Refer to (pages 2-3 thru 2-5) for proper amount and filling procedure.

### 1.4

#### BOOSTER ARRANGEMENTS

Vacuum boosters are available (factory arranged) for belt or direct drive and for vertical or horizontal inlet and discharge.

**2. INSTALLATION**

**2.1 GENERAL**

On receipt of the unit, check for any damage that may have occurred during transit. Report any damage or missing parts as soon as possible.

2.1.1 During installation protective coverings should be left in place to reduce the chances of intrusion of foreign material and rusting. Protection against chemical or salt water atmosphere is not provided. The interior is protected against normal atmospheric corrosion by small bags of an absorbent material fastened to the flange covers.

2.1.2 Before operating, put the required amount of oil into the three oil reservoirs per instructions under Lubrication.

2.1.3 The vacuum booster should be mounted on a smooth, flat, level surface. The degree of variation in level should not exceed .001" per horizontal foot (.0254 mm per horizontal 30.48 cm) in any direction.

2.1.4 Before starting turn drive shaft over manually counterclockwise only to ensure that no foreign material is present in the impeller cavity.

2.1.5 Rotation is as specified by directional arrow on blower. Reversing rotation may require seal and/or timing change.

2.1.6 Inlet and outlet piping should have a proper flexible coupling in the line to prevent rigid piping from distorting the booster housing.

2.1.7 It is important to maintain all pipes and fittings free of debris. If this requirement is not adhered to, jamming and internal damage to the vacuum booster may occur. A Stokes inlet vacuum filter is recommended to provide protection for the booster.

**2.2 BELT DRIVE**

2.2.1 The sheave should be located as close as practical to the booster or back bolt guard and should not overhang the shaft. The motor sheave must be in alignment with the booster sheave and belts tightened according to V-belt manufacturers instructions. Minimum recommended sheave P.D. for vacuum booster is 4.2 inches.

**2.3 DIRECT DRIVE**

2.3.1 The Stokes blowers may be arranged for direct drive with careful consideration of the need for the drive shaft to move axially approximately .020" maximum temperature conditions. See following section 2.3.2 for coupling alignment

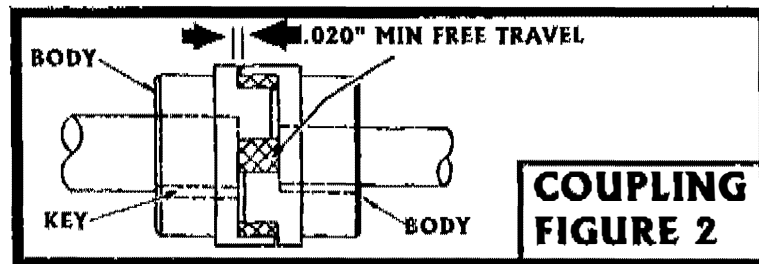

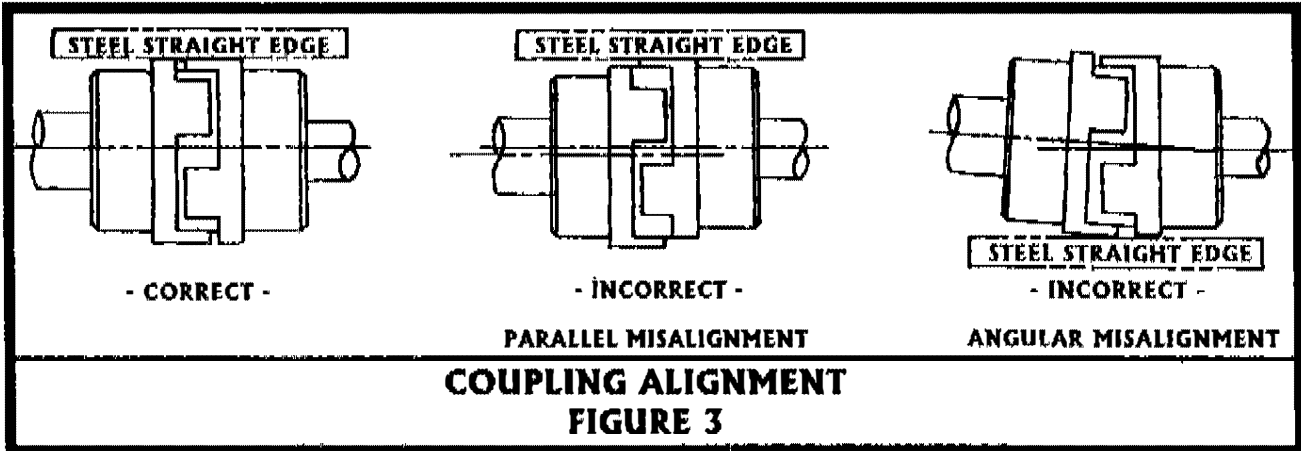

2.3.2 Misalignment can be either parallel or angular. Maximum allowable deviation in offset is .002 (.0508 mm) total indicator reading. The two inside faces of the coupling should not vary more than .001 (.0254 mm) from parallel. See Fig. 3.

**2.4 OXYGEN SERVICE**

2.4.1 Vacuum boosters intended for oxygen service receive special preparation for shipment. In addition to required cleaning, vacuum boosters are backed filled with zero gas air to prevent in leakage of contaminating atmosphere. (Zero gas air is air which has been certified to have total hydrocarbon content of 2.00 PPM as CH4).

2.4.2 Oxygen Service Boosters require special oils. We recommend either Fomblin Y-25/5 or Krytox 1525.

**!!WARNING!!** Substitutes cannot be used. Use of other oils or contamination with hydrocarbons can result in an explosion.

2.4.3 Clean vacuum piping lines (internally) and flanges so they are completely free of hydrocarbon contamination. Use Isotron 113 or equal. Clean a minimum of three (3) times and allow the surfaces to air dry before assembly.

**2.5 CLEANING (Standard Vacuum Booster)**

2.5.1 A clean rag dampened with Loctite safety solvent or equivalent can be used to clean the booster impeller section and flanges if they have accumulated dirt during installation or storage.

**2.6 LUBRICATION (See Figs. 4 and 5)**

2.6.1 The Stokes vacuum booster has three oil reservoirs:

- (A) Seal Reservoir
- (B) Bearing Housing (drive end) Reservoir
- (C) Gear Housing Reservoir

2.6.2 (A) - The seal oil reservoir is vented to atmospheric pressure. The volume of oil that fills the reservoir between the seals is used to lubricate the seal rubbing surface and prevent leakage of atmospheric air into the vacuum booster.

# MODEL 306/310 BLOWER

- 2.6.3 (B) - The bearings in the bearing housing (drive end) reservoir are lubricated by splash from an oil slinger that dips into the oil sump.
- 2.6.4 (C) - In the gear housing reservoir that gears are lubricated by partial immersion in the oil sump. Splash from the gears lubricates both gear end bearings.
- 2.6.5 To fill bearing housing (drive end) and gear housing reservoirs, STOP UNIT AND BREAK VACUUM. LUBRICATING OIL MAY NOT BE ADDED WHILE VACUUM BOOSTER IS IN OPERATION. Note that bearing housing (drive end) and gear housing reservoir may be under vacuum. The following table shows the normal oil capacities of the oil reservoirs. The oil may be added to the lip seal reservoir during operation.

### Appropriate Oil Capacity in Fluid Oz. (Milliliters)

For other than oxygen service, See Note 2 for recommended oil.

PIPING CONNECTION	OZ.		MILLILITERS	
	HORIZONTAL	VERTICAL	HORIZONTAL	VERTICAL
SEAL RESERVOIR	7.75	7.5	229	220
DRIVE END BEARING HOUSING	3.75	7.75	111	230
GEAR HOUSING	8.25	12.5	244	370

- 2.6.6 Fill the three reservoirs with the recommended lubricant to the middle point of the sight glasses. Wait for a period of three minutes to allow oil level to equalize.

**NOTE: DO NOT OVERFILL OR PERMIT OIL LEVEL TO FALL BELOW THE BOTTOM OF THE SIGHT GLASSES**

When the unit is operating the oil level may fluctuate slightly. All fill and drain plugs should be sealed. If the seal reservoir is overfilled, excess oil may flow from the oil cup reservoir when the oil is heated. No harm will be done to the booster if this leakage occurs and the leakage will stop as soon as all excess oil has been expelled. If the drive end bearing or gear end reservoirs are overfilled, oil may spill over into the blower body.

**NOTE: FOR OXYGEN SERVICE BOOSTERS SEE SECTION 2.4 FOR SPECIAL LUBRICANT INSTRUCTIONS.**

**2.7 LUBRICATING SCHEDULE**

**NOTE: OPERATING CONDITIONS DETERMINE FREQUENCY OR OIL CHANGES.**

2.7.1 For normal operating conditions, during the first week, the oil levels on each end of the vacuum booster should be checked every 24 hours of operation. Bearing and gear oil should be changed every 2000 operating hours. Oil in the seal reservoir does not require changing. Add oil to maintain proper level as necessary.

**NOTE: BOTH BEARING OIL RESERVOIRS ARE TO BE FILLED WITH OIL ONLY WHEN THE BLOWER IS MOUNTED IN ITS OPERATING LOCATION.**

2.7.2 Under severe operating conditions such as contamination within the vacuum system or excessively high operating temperatures within the vacuum booster more frequent oil changes are recommended.

**2.8 LUBRICATION DIAGRAM Vertical Flow**

See 2.6.5 for oil quantities.

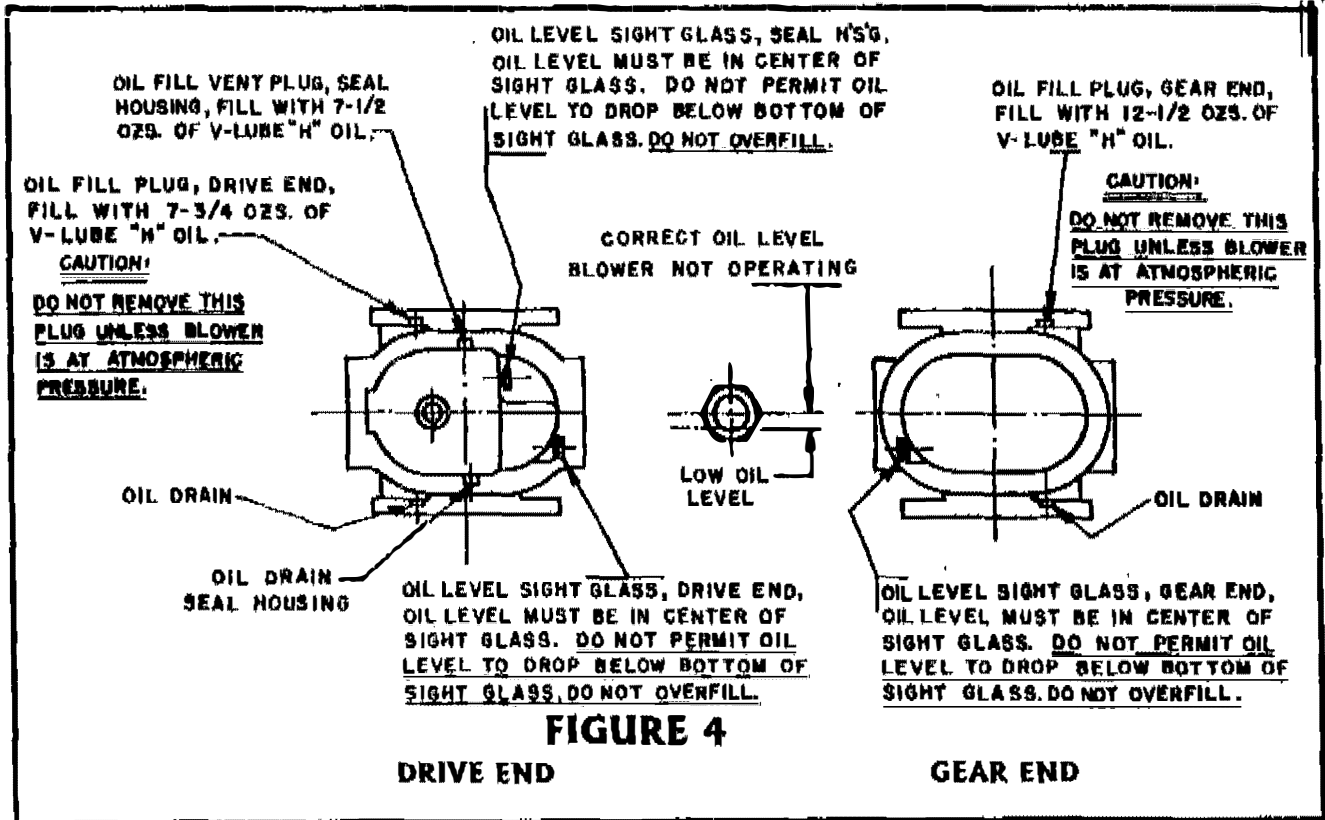

- NOTE:**
- (1) FOR STANDARD APPLICATIONS USE V-LUBE "H" OIL AS LUBRICANT. COAT THREADED PLUGS WITH TEFLON PASTE SEALANT.
  - (2) THERE ARE THREE (3) OIL RESERVOIRS AND THREE (3) OIL FILL PLUGS.
  - (3) ALL OIL FILL PLUGS AND OIL DRAIN PLUGS HAVE STRAIGHT THREADS WITH FLUOROCARBON BROWN "O" RINGS PER MIL. SPEC. MIL-R83248 CL-1.

# MODEL 306/310 BLOWER

- (4) NO THREAD SEALANT IS REQUIRED ON STRAIGHT THREAD PLUGS. THE "O" RING WILL DO THE SEALING. EACH TIME THE FILL OR DRAIN PLUGS ARE REMOVED, THE "O" RING MUST BE INSPECTED FOR CUTS OR DAMAGE & REPLACED IF NECESSARY.
- (5) IF YOUR MODEL BLOWER IS EQUIPPED WITH TAPER PIPE THREAD FILL AND DRAIN PLUGS ON THE DRIVE END AND GEAR END AND YOU HAVE REMOVED THEM FOR SERVICING, IT IS ABSOLUTELY NECESSARY, BEFORE REINSTALLING THEM, THAT THEY BE CLEANED OF OLD THREAD SEALANT AND RECOATED WITH THE PROPER THREAD SEALANT FOR THE SERVICE. SEE NOTE (6) FOR THE PROPER THREAD SEALANTS. NO THREAD SEALANT IS REQUIRED ON STRAIGHT THREAD O-RING TYPE PLUGS; BUT THE O-RING SHOULD BE INSPECTED AND REPLACED IF DAMAGED OR NO LONGER RESILIENT.
- (6) FOR OXYGEN SERVICE USE FOMBLIN Y-25 OIL AS LUBRICANT. COAT THREADED PLUGS WITH OXY-8 PAST SEALANT. OXY-8 CAN BE PROCURED FROM: FLUORAMICS, INCORPORATED.

## 2.9 LUBRICATION DIAGRAM - Horizontal Flow

See 2.6.5 for oil quantities.

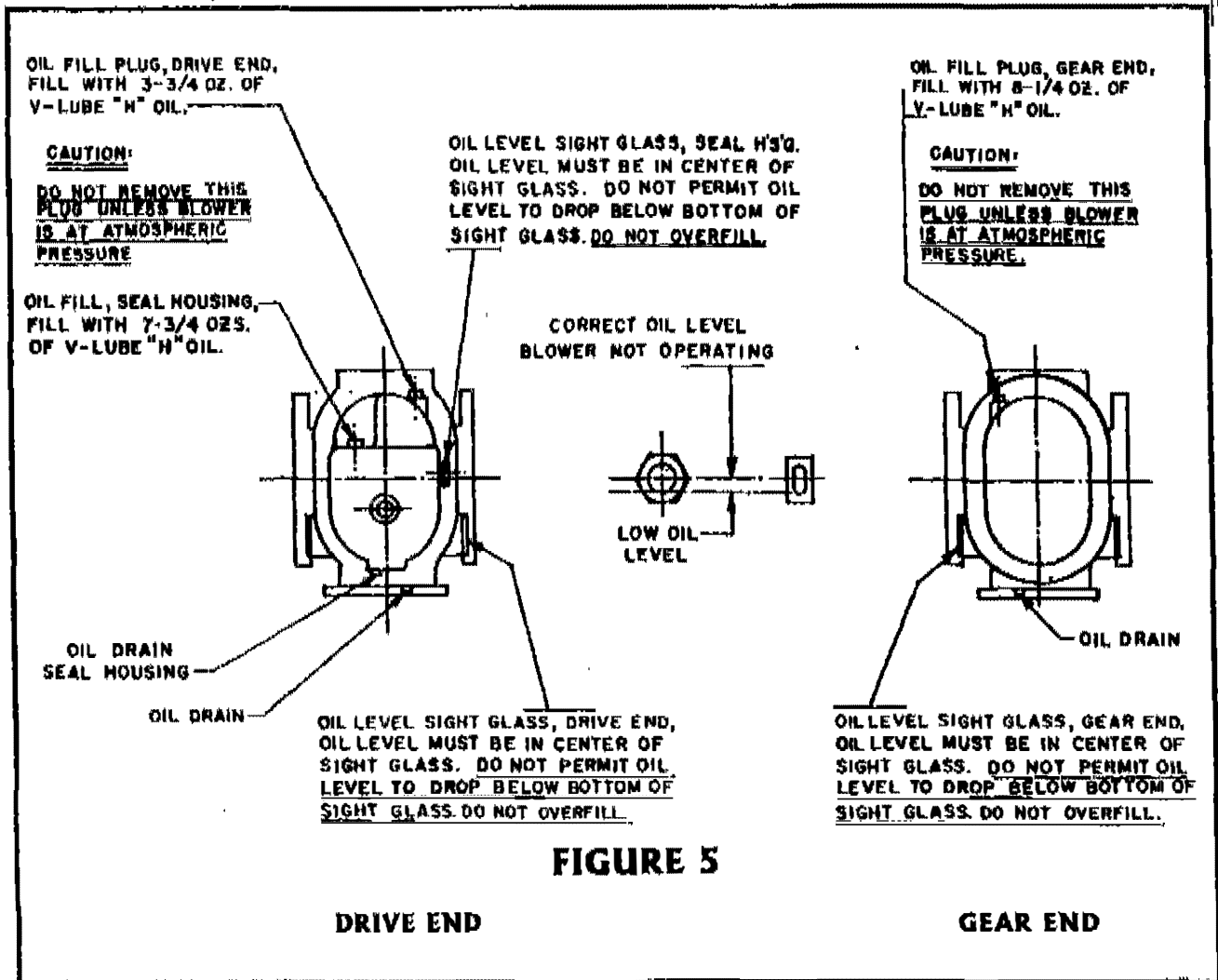

**3.0 OPERATION**

**3.1 OPERATION**

**NOTE: DO NOT ATTEMPT TO OPERATE THE UNIT UNTIL CHECKED PER THE INSTALLATION INSTRUCTIONS.**

- 3.1.1 If the unit rotates freely and direction of rotation is correct, the unit may be started. A preliminary run-in period of five minutes at no-load should reveal any inherent problems. If required, corrections should be made immediately.
- 3.1.2 A one hour run at blank-off should be made to check for loud noises, excessive vibration, seal leakage in the vacuum booster.
- 3.1.3 After steps (1) and (2) have been completed a run at normal pressure conditions for about fifteen minutes should be initiated. Observe the behavior of the vacuum booster for noise and vibration.
- 3.1.4 During initial operation for the first week, observation of oil levels should be on a daily basis to determine if any losses occur. Oil levels should not drop below the bottom of the sight glasses.
- 3.1.5 Periodically check drive belt tension and the booster for unusual noises and increase in vibration.

# SPECIFICATIONS CHART

MODEL 306/310 BLOWER

	UNITS	DISPLACEMENT		MOTOR SPEED	INLET AND OUTLET FLANGES ASA	HEIGHT	FOOTPRINT DIMENSION		OIL CAPACITY	MAX. PRESSURE DIFFERENTIAL	MAX. TEMP. RISE	MAX. DISCHARGE TEMP.		WEIGHT
		CFM	M <sup>3</sup> /HR				INCH	INCH				MM	MM	
306	TEFC DIRECT DRIVE	125	245	1800	3	9.5	32.6 x 11.3		1.75	380	275	375		200
		212	416	3600			241	829 x 288				0.83	135	
306	V-BELT DRIVE	245		3600	3	9.5	18.8 x 11.3		1.75	380	275	375		150
		416					241	476 x 266				0.83	135	
310	TEFC DIRECT	400		3600	4	9.5	38.6 x 11.3		1.75	380	275	375		240
		680					241	930 x 286				0.83	135	
310	V-BELT DRIVE	400		3600	4	9.5	22.8 x 11.3		1.75	380	275	375		190
		680					241	578 x 286				0.83	135	

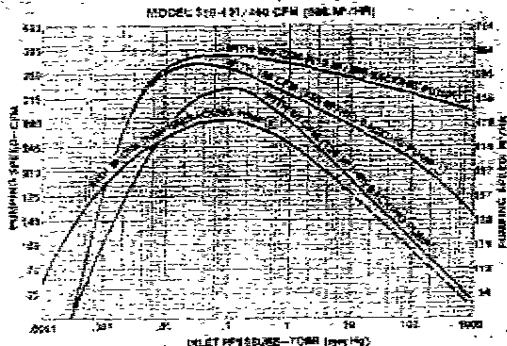
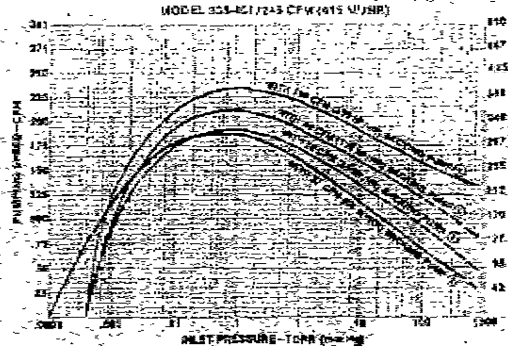
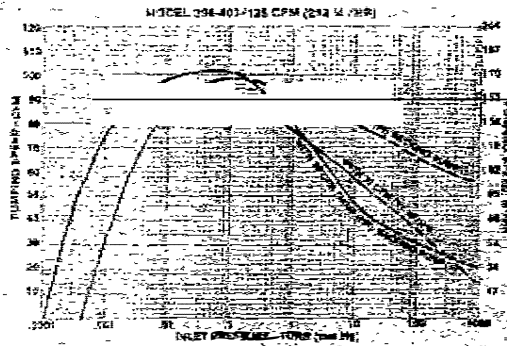



### 306/310 BLOWERS

PLEASE CHECK THE ROTATION ARROW ● ON THE BLOWER BEFORE ORDERING PARTS.

SEAL PARTS KITS ARE IDENTIFIED ON PARTS LIST AND EXPLODED VIEW BY SYM NUMBERS 33 THRU 36.

424-089-001 SEAL PARTS KIT FOR DIRECT DRIVE 306/310 BLOWERS

QTY	PART NUMBER	DESCRIPTION
1	085-040-116	OUTER OIL SEAL
1	085-040-198	INNER OIL SEAL
1	085-040-199	SLEEVE O RING
1	B-429-296-005	SHAFT SLEEVE
2	085-039-008	LOCTITE PRIMER, N
1	085-039-009	LOCTITE RETAINING COMPOUND 620

424-090 001 SEAL PARTS KIT FOR BELT DRIVEN 306/310 BLOWERS

QTY	PART NUMBER	DESCRIPTION
1	085-040-116	OUTER OIL SEAL
1	085-040-198	INNER OIL SEAL
1	085-040-199	SLEEVE O RING
1	B-429-296-007	SHAFT SLEEVE
1	A-424-680-004	KEY, PULLEY
2	085-039-008	LOCTITE PRIMER, N
1	085-039-009	LOCTITE RETAINING COMPOUND 620

BOTH OF THE ABOVE SEAL PARTS KITS HAVE AN INNER SEAL PART # 085-040-198 WHICH IS FOR COUNTER CLOCKWISE ROTATION AND IS PAINTED BLUE ON THE OUTSIDE DIAMETER OF THE SEAL.

FOR BLOWERS BUILT AND TIMED FOR CLOCKWISE OPERATION THEN SUBSTITUTE THE BLUE SEAL 085-040-198 WITH THE RED SEAL PART NUMBER 085-040-426. THE OUTSIDE DIAMETER OF THIS SEAL IS PAINTED RED.

**ROTATION IDENTIFICATION CHART**

**MODEL 306/310 BLOWER**

<b>MODEL NO.</b>	<b>DESCRIPTION</b>	<b>ROTATION</b>
306-001	VERTICAL FLOW DIRECT DRIVE BLOWER	CCW
306-002	HORIZONTAL FLOW BLOWER, FOOT MOUNTING	CCW
306-003	HORIZONTAL FLOW BLOWER, BELT DRIVE	CW
306-401	VERTICAL FLOW DIRECT DRIVE BLOWER	CCW
306-402	HORIZONTAL FLOW DIRECT DRIVE BLOWER, FOOT MOUNTING	CCW
306-403	VERTICAL FLOW DIRECT DRIVE BLOWER	CCW
306-404	HORIZONTAL FLOW DIRECT DRIVE BLOWER, FOOT MOUNTING	CCW
306-405	VERTICAL FLOW DIRECT DRIVE BLOWER	CCW
310-001	VERTICAL FLOW BELT DRIVE BLOWER	CCW
310-002	HORIZONTAL FLOW BELT DRIVE BLOWER, FOOT MOUNTING	CCW
310-003	HORIZONTAL FLOW BELT DRIVE BLOWER, FOOT MOUNTING	CW
310-401	VERTICAL FLOW DIRECT DRIVE BLOWER	CCW
310-402	HORIZONTAL FLOW DIRECT DRIVE BLOWER, FOOT MOUNTING	CCW

**WHEN ORDERING PARTS, PLEASE SPECIFY ROTATION OF YOUR BLOWER.**

### MODEL 306 HORIZONTAL FLOW BLOWERS

SYM	PART NO.	DESCRIPTION	REF. DWG./ COMP. LIT.	QTY	UM	RSP	306-2	306-3	306-402
1	423-882-002	RESERVIOR COVER (NEW STYLE)	B-423-882-002	1	EA		X	X	
1	423-898-004	MOTOR SUPPORT	D-423-898-004-B	1	EA				X
1A	085-038-990	O RING		1	EA	✓	X	X	X
1B	022-002-240	O RING (OLD STYLE CASTING)		1	EA		X	X	X
2	424-663-003	PORT COVER	A-424-663-003	1	EA		X	X	X
3	424-697-006	SEAL HOUSING	F-424-697-006	1	EA		X	X	X
5	424-667-001	CLAMP COLLAR	A-424-667-001-B	1	EA		X	X	X
6	425-256-002	SLINGER DRIVE END	A-425-256-002	1	EA		X	X	X
8	425-019-001	SPACER SHAFT	A-425-019-001-B	3	EA		X	X	X
9	085-037-646	BRG B RAD DBL		3	EA	✓	X	X	X
10	085-037-653	WASHER WAVE		4	EA		X	X	X
11	425-037-001	LABYRINTH SEAL ROTATING	A-425-037-001-C	4	EA		X	X	X
12	425-016-002	LABYRINTH SEAL FIXED	A-425-016-002-C	4	EA		X	X	X
13	424-694-017	BRG HOUSING (GEAR END)	F-424-694-017	1	EA		X	X	X
13A	424-694-018	BRG HOUSING (DRIVE END)	F-424-694-018	1	EA		X	X	X
14	424-695-001	PUMP BODY	F-424-695-001-G	1	EA		X	X	X
14A	426-114-001	MOUNTING FOOT	A-426-114-001	1	EA		X	X	X
15	423-872-010	IMPELLER DRIVE SOLID 306-401	D-423-872-010-A	1	EA		X	X	X
16	425-011-002	BEARING RETAINER SPLIT	A-425-011-002-A	3	EA		X	X	X
18	085-038-843	SHIM ARBOR STL		3	EA		X	X	X
19	424-651-006	KEY GEAR	A-424-651-006-D	2	EA		X	X	X
19A	424-680-004	PULLEY KEY	A-424-680-004	1	EA		X	X	X
20	085-038-257	GEAR HELICAL		1	EA		X	X	X
21	423-894-001	WASHER	A-423-894-001	3	EA		X	X	X
22	424-698-004	GEAR COVER	D-424-698-004-C	1	EA		X	X	X
24	085-038-847	SHIM ARBOR		5	EA		X	X	X
24	085-038-846	SHIM RD ST		4	EA		X	X	X
24	085-038-845	SHIM RD STL		1	EA		X	X	X
24	085-038-844	SHIM RD ST		1	EA		X	X	X
24	085-039031	SHIM RD ST		1	EA		X	X	X
25	423-874-008	IMPELLER DRIVEN SOLID 306-401	D-423-874-008-A	1	EA		X	X	X
26	085-037-645	BEARING BALL RADIAL SGL ROW		1	EA	✓	X	X	X
27	085-040-332	GAUGE SIGHT LEVEL WINDOW TYPE		3	EA	✓	X	X	X
27B	426-108-001	SIGHT GLASS		2	EA		X	X	X

**RSP = REPLACEMENT SPARE PARTS**  
**UM = UNIT OF MEASURE**



OIL CAPACITY  
 $1\frac{3}{4}$  PINTS (0.8LITERS)  
 APPROX. WT.  
 130 LBS. (68kg)

BLOWER SHAFT  
 ROTATION  
 BOTTOM OUTLET  
 (FOR TOP OUTLET  
 CONSULT FACTORY)

3" STD. FLANGE CONN.(76mm)  
 $\frac{3}{8}$ "-11 TAP (4) HOLES  
 THRU ON 6" B.C.  
 STRADDLE 4'S  
 TOP & BOTTOM

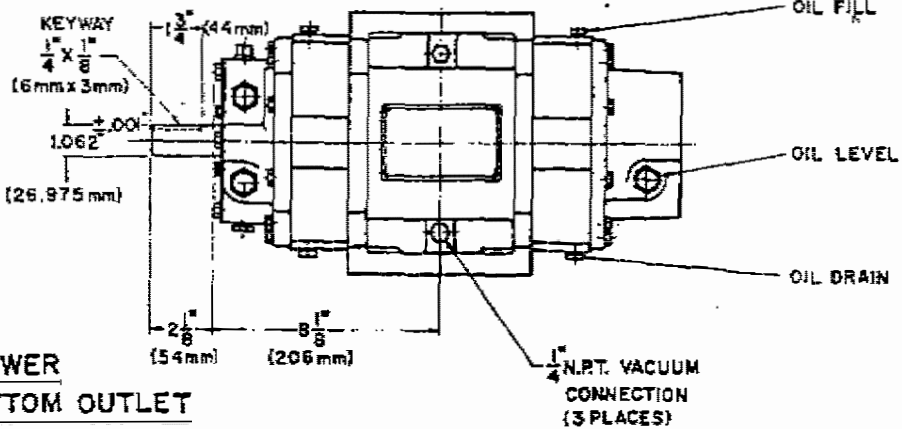
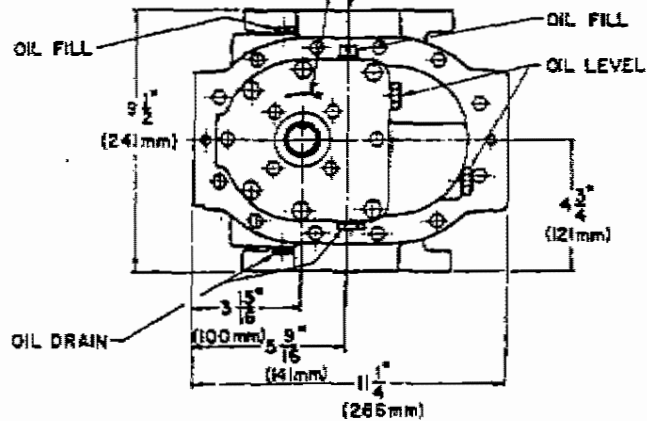
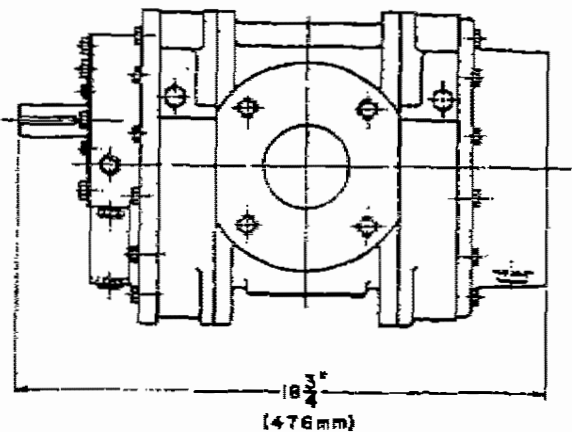

BLOWER  
BOTTOM OUTLET  
 PRODUCT CODE 900-306-1

125 C.F.M.(212M<sup>3</sup>/HR) at 1800 R.P.M.  
 245 C.F.M.(415M<sup>3</sup>/HR) at 3600 R.P.M.

DWG NO D-425-291-2

OIL CAPACITY  
 $1\frac{3}{4}$  PINTS  
APPROX. WT.  
200 LBS.

BLOWER SHAFT  
ROTATION  
BOTTOM OUTLET  
(FOR TOP OUTLET  
CONSULT FACTORY)

BLOWER MOTOR  
2 HP, 3600 RPM.  
230-460/3/60  
OTHER VOLTAGES  
& HZ. AVAILABLE

3" STD. FLANGE CONN.  
 $\frac{5}{8}$ "-11 TAP (4) HOLES  
THRU ON 6" B.C.  
STRADDLE  $\phi$ 'S

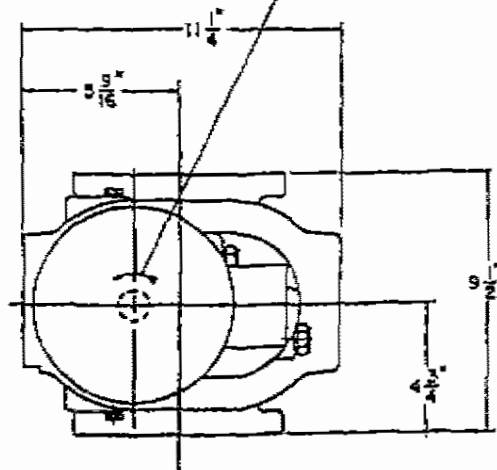

OIL FILL

NPT. INSTRUMENT  
CONNECTION  
(3) PLACES

OIL FILL

OIL LEVEL

OIL DRAIN

OIL LEVEL

OIL DRAIN

32 1/2"

### DIRECT DRIVE VACUUM BOOSTER

PRODUCT CODE 900-306-401

125 C.F.M. at 1800 R.P.M.

245 C.F.M. at 3600 R.P.M.

DWG. NO. D-425-551-4

**MODEL 306 VERTIC. FLOW BLOWERS**

SYM	PART NO.	DESCRIPTION	REF. DWG./ COMP. LIT.	QTY	UM	RSP	306-1	306-401	306-403	306-405
1	423-882-002	RESERVIOR COVER (NEW STYLE)	B-423-882-002	1	EA		X			
1	423-898-004	MOTOR SUPPORT	D-423-898-004-B	1	EA			X	X	
1	605-662-001	MOTOR SUPPORT	D-605-662-001	1	EA					X
1A	085-038-990	O RING		1	EA	✓	X	X	X	X
1B	022-002-240	O RING (OLD STYLE CASTING)		1	EA	✓	X	X	X	X
2	424-663-003	PORT COVER	A-424-663-003	1	EA			X	X	X
3	424-697-004	SEALHOUSING	F-424-697-004-F	1	EA		X	X	X	X
5	424-667-001	CLAMP COLLAR	A-424-667-001-B	1	EA		X	X	X	X
6	425-256-002	SLINGER DRIVE END	A-425-256-002	1	EA		X	X	X	X
8	425-019-001	SPACER SHAFT	A-425-019-001-B	3	EA		X	X	X	X
9	085-037-646	BRG B RAD DBL		3	EA	✓	X	X	X	X
10	085-037-653	WASHER WAVE		4	EA		X	X	X	X
11	425-037-001	LABYRINTH SEAL ROTATING	A-425-037-001-C	4	EA		X	X	X	X
12	425-016-002	LABYRINTH SEAL FIXED	A-425-016-002-C	4	EA		X	X	X	X
13	424-694-009	BRG HOUSE	F-424-694-009-G	2	EA		X	X	X	X
14	424-695-001	PUMP BODY	F-424-695-001-G	1	EA		X	X	X	X
15	423-872-010	IMPELLER DRIVE SOLID 306-401	D-423-872-010-A	1	EA		X	X	X	X
16	425-011-002	BEARING RETAINER SPLIT	A-425-011-002-A	3	EA		X	X	X	X
18	085-038-843	SHIM ARBOR STL		3	EA		X	X	X	X
19	424-651-006	KEY GEAR	A-424-651-006-D	2	EA		X	X	X	X
19A	424-680-004	PULLEY KEY	A-424-680-004	1	EA		X	X	X	X
20	085-038-257	GEAR HELICAL		1	EA		X	X	X	X
21	423-894-001	WASHER	A-423-894-001	3	EA		X	X	X	X
22	424-698-004	GEAR COVER	D-424-698-004-C	1	EA		X	X	X	X
24	085-038-847	SHIM ARBOR		5	EA		X	X	X	X
24	085-038-846	SHIM RD ST		4	EA		X	X	X	X
24	085-038-845	SHIM RD STL		1	EA		X	X	X	X
24	085-038-844	SHIM RD ST		1	EA		X	X	X	X
24	085-039-031	SHIM RD ST		1	EA		X	X	X	X
25	423-874-008	IMPELLER DRIVEN SOLID 306-401	D-423-874-008-A	1	EA		X	X	X	X
26	085-037-645	BEARING BALL RADIAL SGL ROW		1	EA	✓	X	X	X	X
27	085-040-332	GAUGE SIGHT LEVEL WINDOW TYPE		3	EA	✓	X	X	X	X
28	429-905-005	BREATHER VENT PLUG	A-429-905-005	1	EA		X	X	X	X
29	423-882-001	RESERVOIR COVER PLATE (OLD STYLE) NO LONGER AVAILABLE	B-423-882-001	1	EA		X			





OIL CAPACITY

$1\frac{3}{4}$  PINTS (0.8LITER)

APPROX. WT.

150 LBS. (68kg.)

BLOWER SHAFT  
ROTATION  
RIGHT OUTLET  
(FOR LEFT OUTLET  
CONSULT FACTORY)

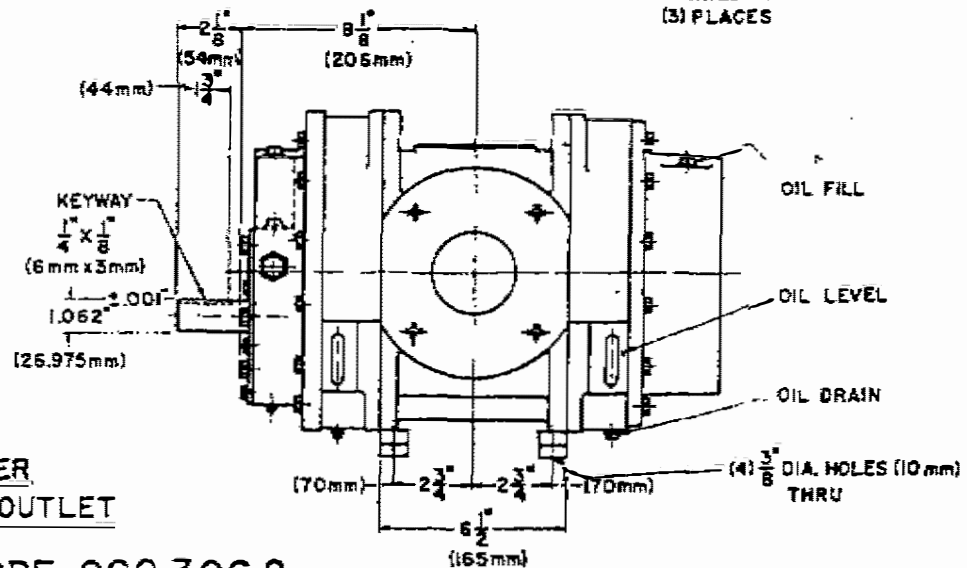
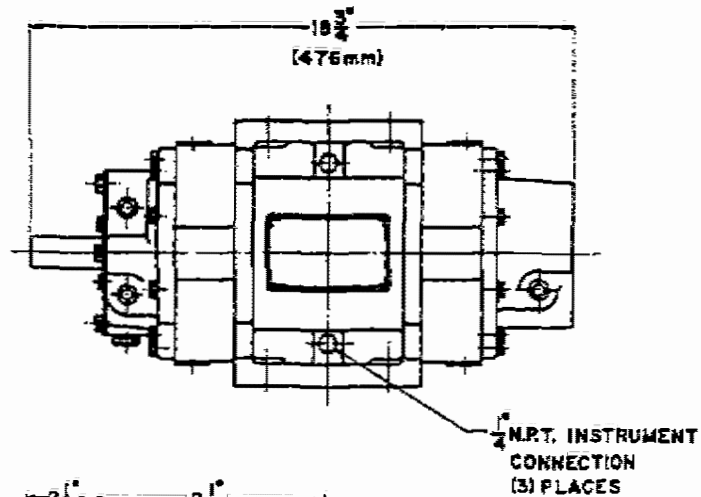
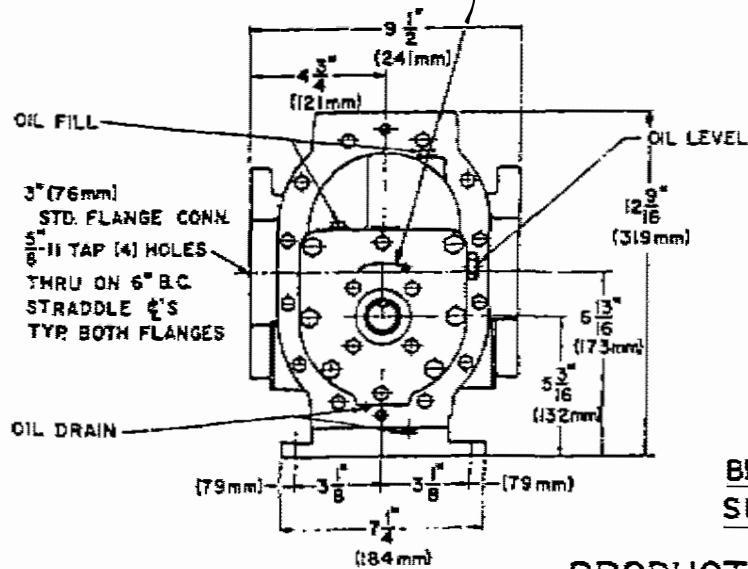

BLOWER  
SIDE OUTLET

PRODUCT CODE 900-306-2

125 C.F.M. (212 M<sup>3</sup>/HR) at 1800 R.P.M.  
245 C.F.M. (415 M<sup>3</sup>/HR) at 3600 R.P.M.

DWG. NO. D-425-779-2

OIL CAPACITY:  
 $1\frac{3}{4}$  PINTS (0.8 LITER)  
 APPROX. WT.:  
 210 LBS. (91 kg)

BLOWER SHAFT  
 ROTATION  
 RIGHT OUTLET  
 (FOR LEFT OUTLET  
 CONSULT FACTORY)

BLOWER MOTOR AVAILABLE IN  
 2 HP, 3600 RPM. (1.5 KW), OR 1.5 HP  
 1800 RPM. (1.1 KW), 230-460/3/60  
 OTHER VOLTAGES & HZ. AVAILABLE

3" STD. FLANGE CONN. (76 mm)  
 $\frac{5}{8}$ " TAP (4) HOLES THRU  
 ON 6" B.C. STRADDLE C'S

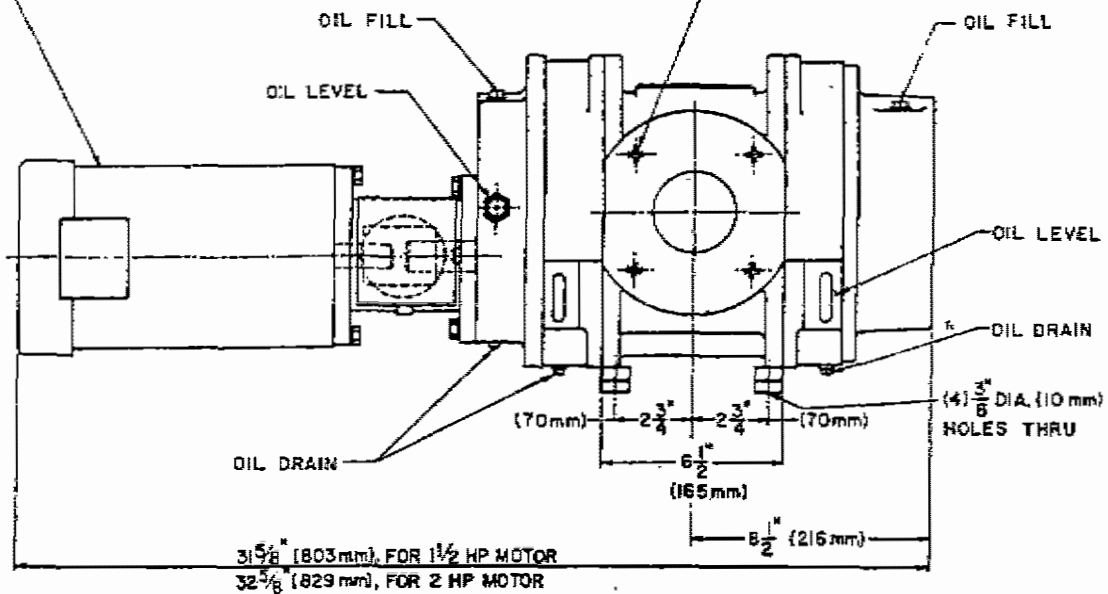
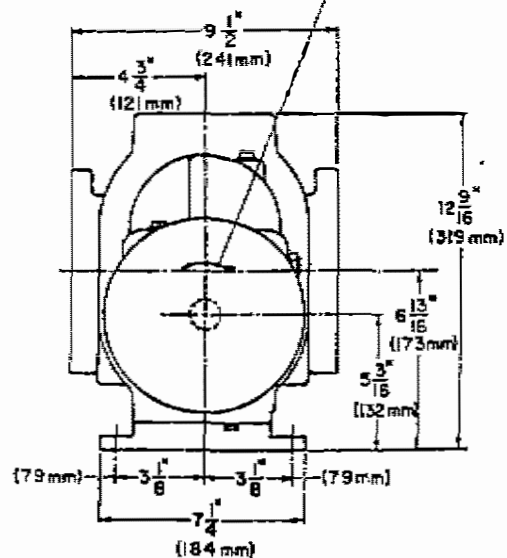

### DIRECT DRIVE BLOWER

PRODUCT CODE 900-306-404 125 C.F.M. (212 M<sup>3</sup>/HR) @ 1800 R.P.M.  
 PRODUCT CODE 900-306-402 245 C.F.M. (415 M<sup>3</sup>/HR) @ 3600 R.P.M.

### MODEL 310 HORIZONTAL FLOW BLOWERS

SYM	PART NO.	DESCRIPTION	REF. DWG./ COMP. LIT.	QTY	UM	RSP	310-2	310-3	310-402
1	423-882-002	RESERVIOR COVER (NEW STYLE)	B-423-882-002	1	EA		X	X	
1	423-898-004	MOTOR SUPPORT	D-423-898-004-B	1	EA				X
1A	085-038-990	O RING		1	EA	✓	X	X	X
1B	022-002-240	O RING (OLD STYLE CASTING)		1	EA		X	X	X
2	424-663-003	PORT COVER	A-424-663-003	1	EA		X	X	X
3	424-697-006	SEAL HOUSING	F-424-697-006	1	EA		X	X	X
5	424-667-001	CLAMP COLLAR	A-424-667-001-B	1	EA		X	X	X
6	425-256-002	SLINGER DRIVE END	A-425-256-002	1	EA		X	X	X
8	425-019-001	SPACER SHAFT	A-425-019-001-B	3	EA		X	X	X
9	085-037-646	BRG B RAD DBL		3	EA	✓	X	X	X
10	085-037-653	WASHER WAVE		4	EA		X	X	X
11	425-037-001	LABYRINTH SEAL ROTATING	A-425-037-001-C	4	EA		X	X	X
12	425-016-002	LABYRINTH SEAL FIXED	A-425-016-002-C	4	EA		X	X	X
13	424-694-017	BRG HOUSING (GEAR END)	F-424-694-017	1	EA		X	X	X
13A	424-694-018	BRG HOUSING (DRIVE END)	F-424-694-018	1	EA		X	X	X
14	424-696-007	3210 PUMP BODY	F-424-696-007	1	EA		X	X	X
14A	426-114-001	MOUNTING FOOT	A-426-114-001	1	EA		X	X	X
15	423-871-011	IMPELLER DRIVE SOLID 310-401	D-423-871-011	1	EA		X	X	X
16	425-011-002	BEARING RETAINER SPLIT	A-425-011-002-A	3	EA		X	X	X
18	085-038-843	SHIM ARBOR STL		3	EA		X	X	X
19	424-651-006	KEY GEAR	A-424-651-006-D	2	EA		X	X	X
19A	424-680-004	PULLEY KEY	A-424-680-004	1	EA		X	X	X
20	085-038-257	GEAR HELICAL		1	EA		X	X	X
21	423-894-001	WASHER	A-423-894-001	3	EA		X	X	X
22	424-698-004	GEAR COVER	D-424-698-004-C	1	EA		X	X	X
24	085-038-847	SHIM ARBOR		5	EA		X	X	X
24	085-038-846	SHIM RD ST		4	EA		X	X	X
24	085-038-845	SHIM RD STL		1	EA		X	X	X
24	085-038-844	SHIM RD ST		1	EA		X	X	X
24	085-039-031	SHIM RD ST		1	EA		X	X	X
25	423-873-008	IMPELLER DRIVEN SOLID 310-401	D-423-873-008	1	EA		X	X	X
26	085-037-645	BEARING BALL RADIAL SGL ROW		1	EA	✓	X	X	X
27	085-040-332	GAUGE SIGHT LEVEL WINDOW TYPE		3	EA	✓	X	X	X
27B	426-108-001	SIGHT GLASS		2	EA		X	X	X



OIL CAPACITY  
 $1\frac{3}{4}$  PINTS (0.8 LITER)  
 APPROX. WT.  
 (80 LBS. (36 kg.))

BLOWER SHAFT  
 ROTATION  
 BOTTOM OUTLET  
 (FOR TOP OUTLET  
 CONSULT FACTORY)

4" STD. FLANGE CONN. (102 mm)  
 $\frac{5}{8}$ "-11 TAP (8) HOLES  
 EQUALLY SPACED ON  
 $7\frac{1}{2}$ " B.C. STRADDLE G'S  
 (TOP & BOTTOM)

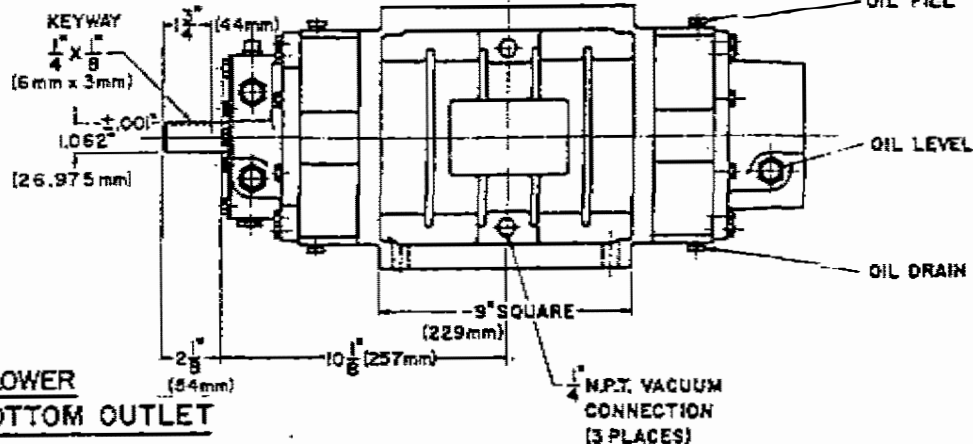
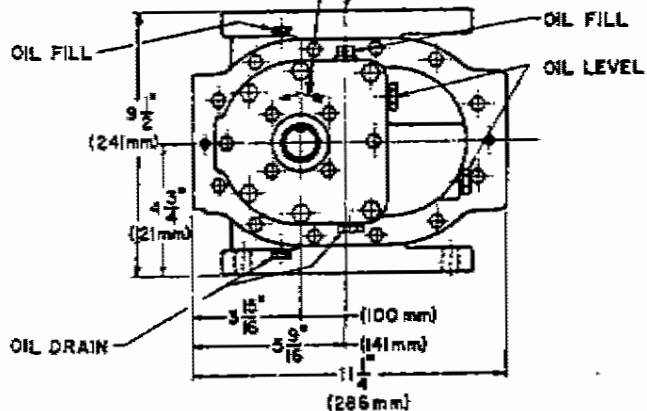
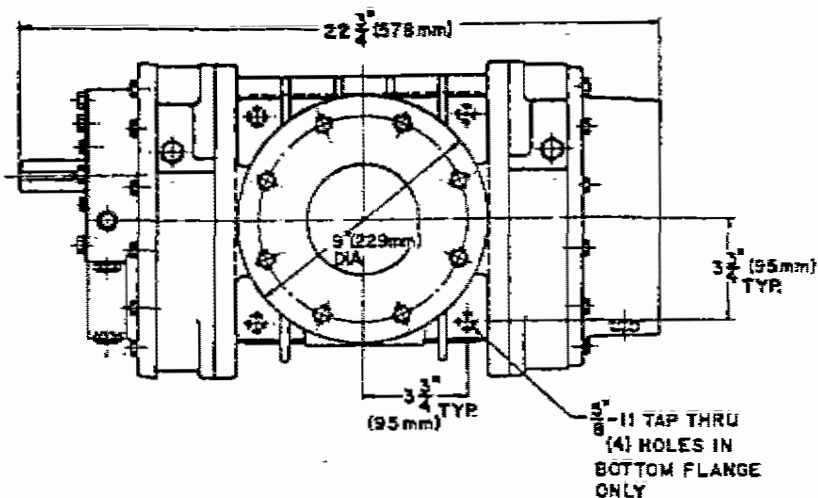

BLOWER  
BOTTOM OUTLET

PRODUCT CODE 900-310-1

400 C.F.M. (680 M<sup>3</sup>/HR) at 3600 R.P.M.

DWG. NO. D-425-561-2

OIL CAPACITY  
 $1\frac{3}{4}$  PINTS  
 APPROX. WT.  
 240 LBS.

BLOWER SHAFT  
 ROTATION  
 BOTTOM OUTLET  
 (FOR TOP OUTLET  
 CONSULT FACTORY)

BLOWER MOTOR  
 2 HP, 3600 RPM  
 230-460 / 3/60  
 OTHER VOLTAGES  
 & HZ AVAILABLE

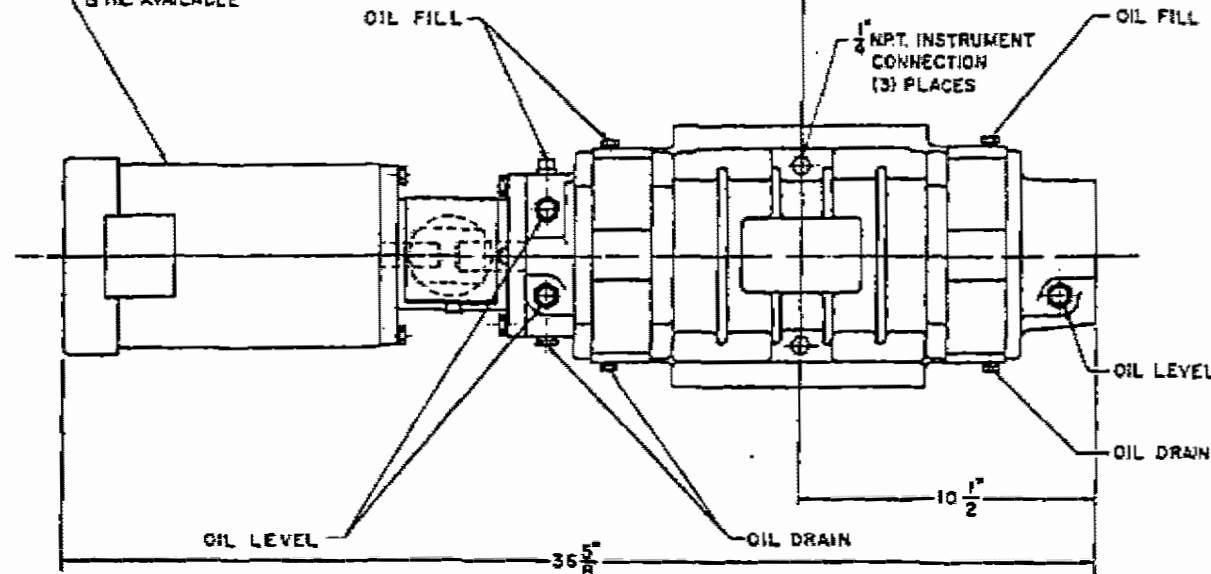
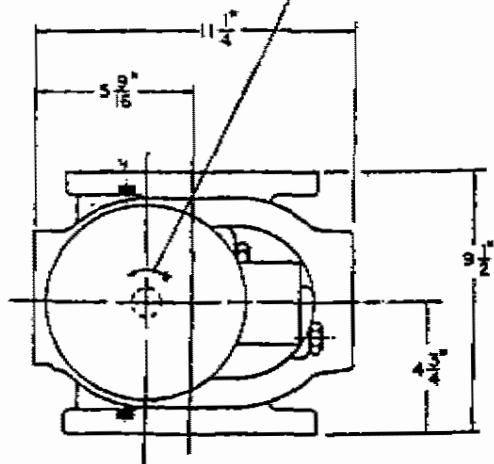
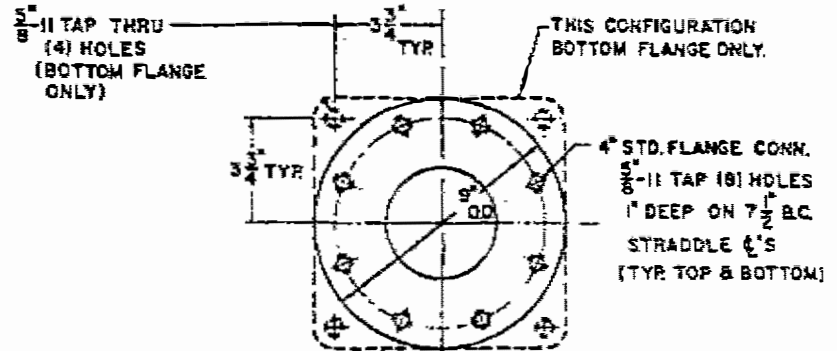

**DIRECT DRIVE VACUUM BOOSTER (400 CFM)**

**PRODUCT CODE 900-310-401**

DWG. NO. D-425-552-3

**MODEL 310 VERTICAL FLOW BLOWERS**

<b>SYM</b>	<b>PART NO.</b>	<b>DESCRIPTION</b>	<b>REF. DWG./ COMP. LIT.</b>	<b>QTY</b>	<b>UM</b>	<b>RSP</b>	<b>310-1</b>	<b>310-401</b>
1	423-882-002	RESERVIOR COVER (NEW STYLE)	B-423-882-002	1	EA		X	
1	423-898-004	MOTOR SUPPORT	D-423-898-004-B	1	EA			X
1	605-662-001	MOTOR SUPPORT	D-605-662-001	1	EA			
1A	085-038-990	O RING		1	EA	✓	X	X
1B	022-002-240	O RING (OLD STYLE CASTING)		1	EA	✓	X	X
2	424-663-003	PORT COVER	A-424-663-003	1	EA			X
3	424-697-004	SEALHOUSING	F-424-697-004-F	1	EA		X	X
5	424-667-001	CLAMP COLLAR	A-424-667-001-B	1	EA		X	X
6	425-256-002	SLINGER DRIVE END	A-425-256-002	1	EA		X	X
8	425-019-001	SPACER SHAFT	A-425-019-001-B	3	EA		X	X
9	085-037-646	BRG B RAD DBL		3	EA	✓	X	X
10	085-037-653	WASHER WAVE		4	EA		X	X
11	425-037-001	LABYRINTH SEAL ROTATING	A-425-037-001-C	4	EA		X	X
12	425-016-002	LABYRINTH SEAL FIXED	A-425-016-002-C	4	EA		X	X
13	424-694-009	BRG HOUSE	F-424-694-009-G	2	EA		X	X
14	424-698-007	3210 PUMP BODY	F-424-698-007	1	EA		X	X
15	423-871-011	IMPELLER DRIVE SOLID 310-401	D-423-871-011	1	EA		X	X
16	425-011-002	BEARING RETAINER SPLIT	A-425-011-002-A	3	EA		X	X
18	085-038-843	SHIM ARBOR STL		3	EA		X	X
19	424-651-006	KEY GEAR	A-424-651-006-D	2	EA		X	X
19A	424-680-004	PULLEY KEY	A-424-680-004	1	EA		X	X
20	085-038-257	GEAR HELICAL		1	EA		X	X
21	423-894-001	WASHER	A-423-894-001	3	EA		X	X
22	424-698-004	GEAR COVER	D-424-698-004-C	1	EA		X	X
24	085-038-847	SHIM ARBOR		5	EA		X	X
24	085-038-846	SHIM RD ST		4	EA		X	X
24	085-038-845	SHIM RD STL		1	EA		X	X
24	085-038-844	SHIM RD ST		1	EA		X	X
24	085-039-031	SHIM RD ST		1	EA		X	X
25	423-873-008	IMPELLER DRIVEN SOLID 310-401	D-423-873-008	1	EA		X	X
26	085-037-645	BEARING BALL RADIAL SGL ROW		1	EA	✓	X	X
27	085-040-332	GAUGE SIGHT LEVEL WINDOW TYPE		3	EA	✓	X	X
28	429-905-005	BREATHER VENT PLUG	A-429-905-005	1	EA		X	X
29	423-882-001	RESERVOIR COVER PLATE (OLD STYLE) NO LONGER AVAILABLE	B-423-882-001	1	EA		X	

**RSP = REPLACEMENT SPARE PARTS**  
**UM = UNIT OF MEASURE**





OIL CAPACITY  
 $1\frac{3}{4}$  PINTS  
 APPROX. WT.  
 190 LBS.

BLOWER SHAFT  
 ROTATION  
 RIGHT OUTLET  
 (FOR LEFT OUTLET  
 CONSULT FACTORY)

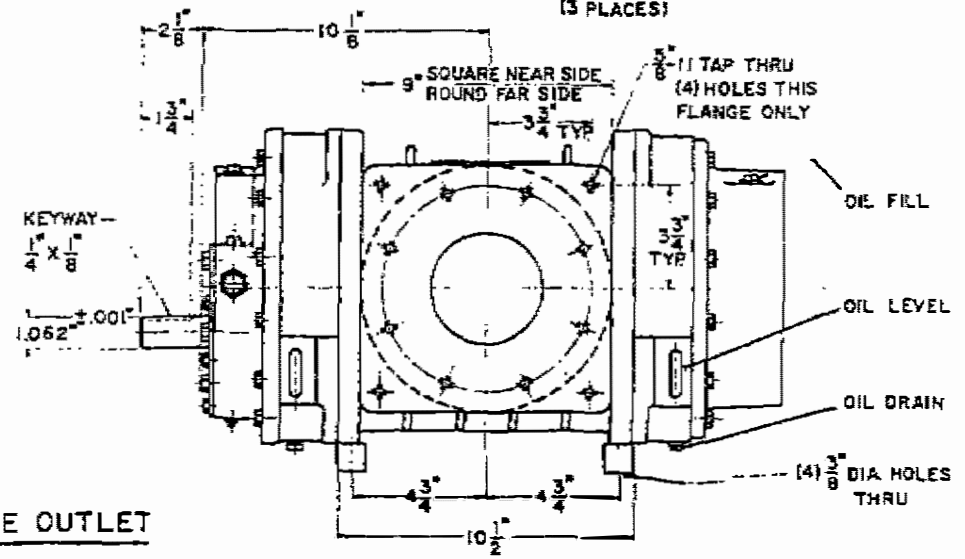
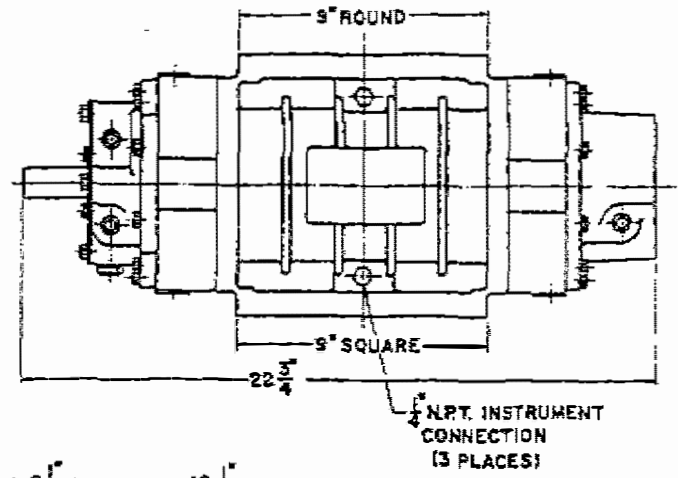
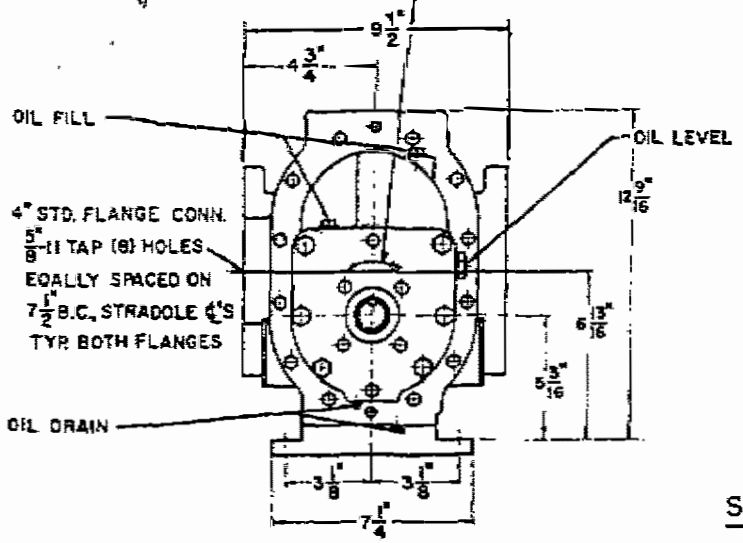

SIDE OUTLET

PRODUCT CODE 900-310-2

400 C.F.M. at 3600 R.P.M.

DWG. NO. D-425-780-2

OIL CAPACITY:

$1\frac{3}{4}$  PNTS (0.8 LITER)

APPROX. WT.:

250 LBS. (109 kg)

BLOWER SHAFT  
ROTATION  
RIGHT OUTLET  
(FOR LEFT OUTLET  
CONSULT FACTORY)

BLOWER MOTOR 2 HP, 3600 RPM. (1.5 KW)  
230-460/3/60, OTHER VOLTAGES &  
HZ. AVAILABLE

4" (102mm) STD. FLANGE CONN.  
 $\frac{5}{8}$ "-11 TAP (6) HOLES 1" DEEP  
ON  $7\frac{1}{2}$ " B.C. STRADDLE C'S  
TYR. BOTH FLANGES

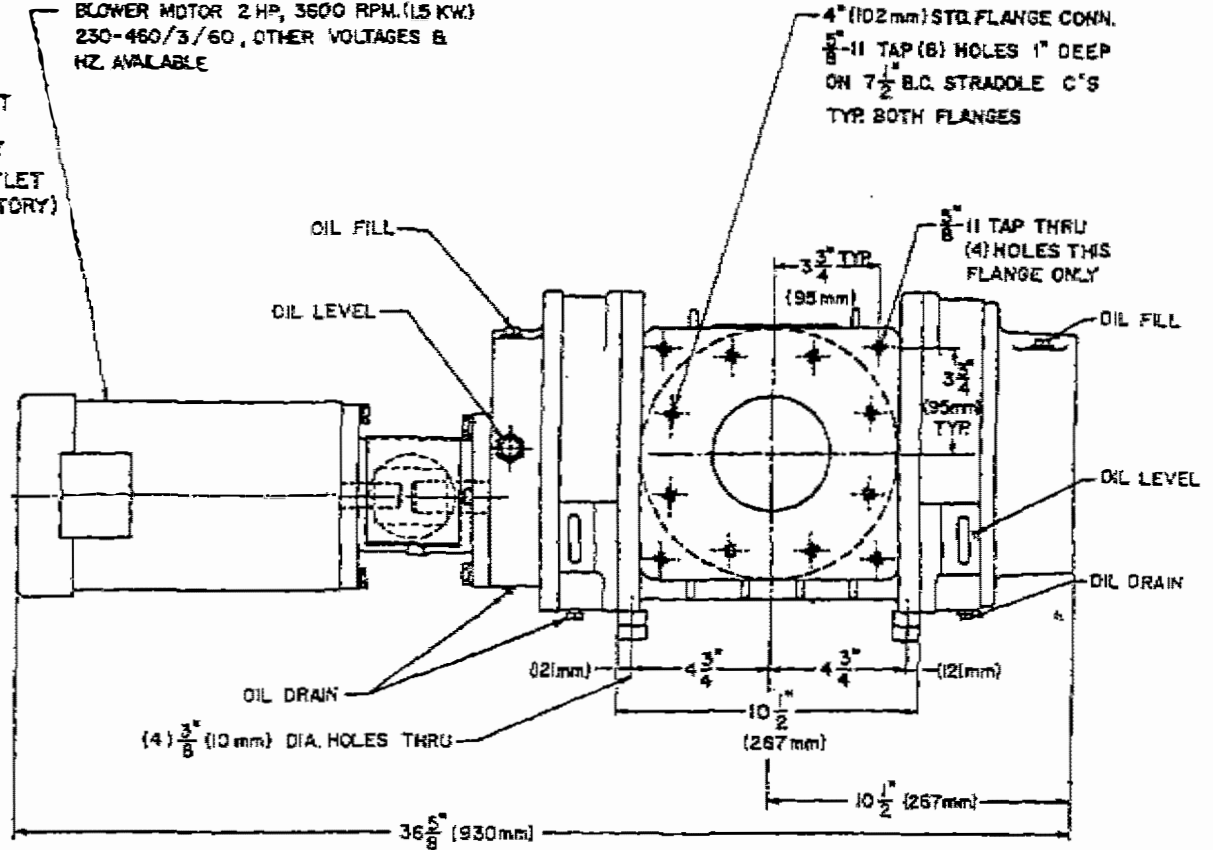
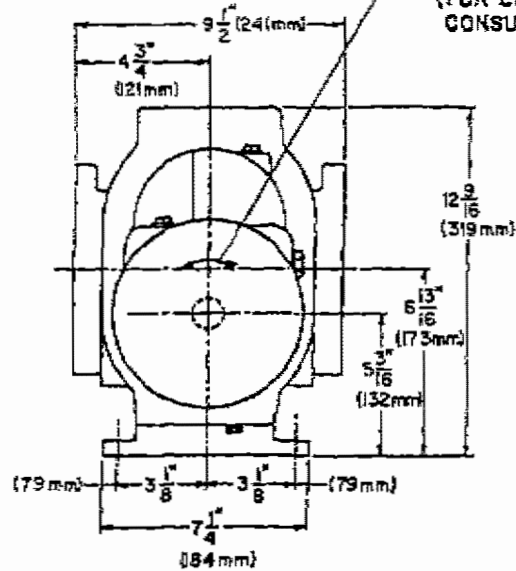

DIRECT DRIVE BLOWER (400 C.F.M.)(680 M<sup>3</sup>/HR)

PRODUCT CODE 900-310-402

DWG. NO. D-425-552-4

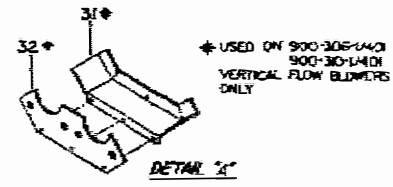
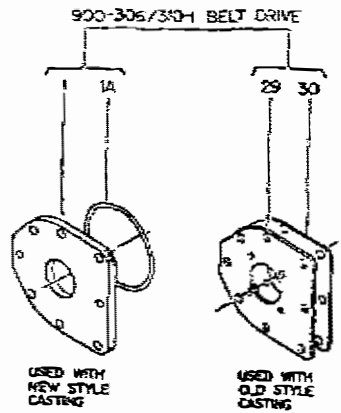

\* USED ON 900-306/401  
900-310/401  
VERTICAL FLOW BLOWERS  
ONLY

900-306/310-401  
DIRECT DRIVE

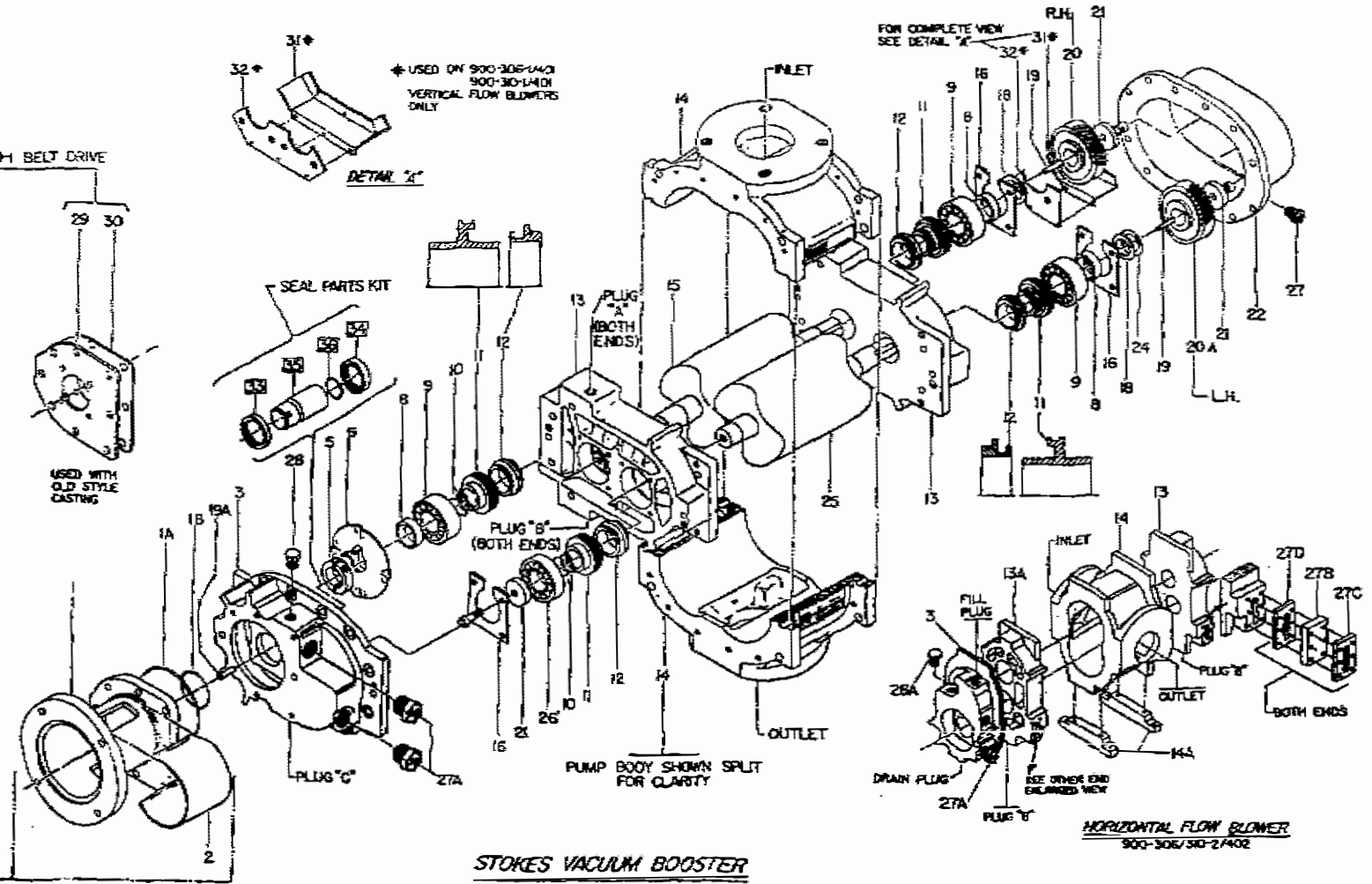

STOKES VACUUM BOOSTER

HORIZONTAL FLOW BLOWER  
900-306/310-2/402

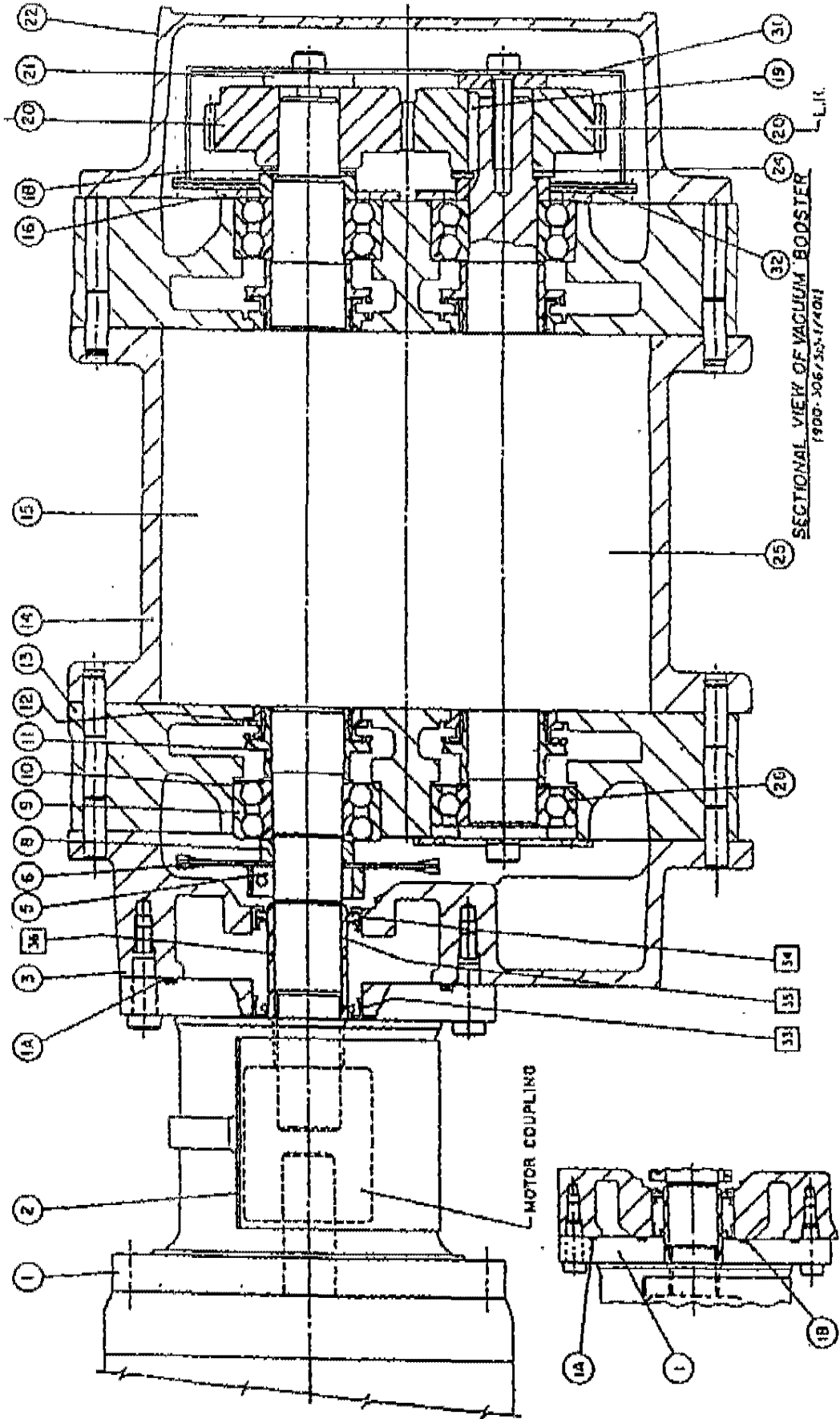

SECTIONAL VIEW OF VACUUM BOOSTER  
 1900-306/35-17401

D-0-345

L.I.K.