

Control Gate Valve

with 3-position pneumatic actuator

This manual is valid for the valve ordering number(s):
 640.. - .E.8 -

The fabrication number is indicated on each product as per the label below (or similar):

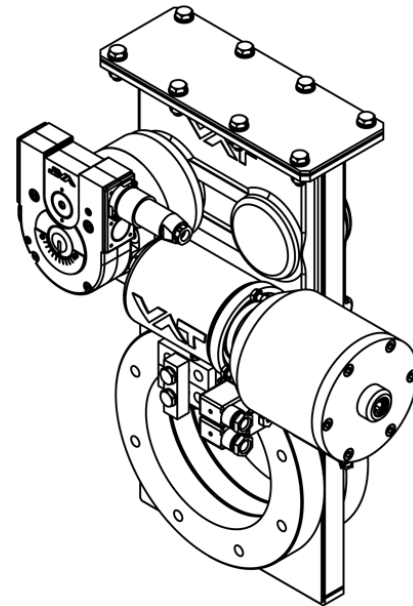
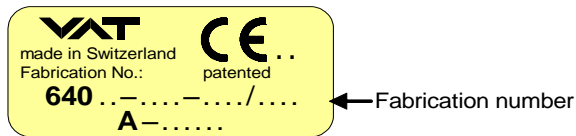

Sample picture

Explanation of symbols:



Read declaration carefully before you start any other action!



Keep body parts and objects away from the valve opening!



Attention!



Hot surfaces; do not touch!



Product is in conformity with EC guidelines, if applicable!



Loaded springs and/or air cushions are potential hazards!



Disconnect electrical power and compressed air lines. Do not touch parts under voltage!



Wear gloves!



Read these «**Installation, Operating & Maintenance Instructions**» and the enclosed «**General Safety Instructions**» carefully before you start any other action!



FOR SALES AND SERVICE PLEASE CALL:

PTB SALES T :: 626.334.0500
 sales@ptbsales.com
 service@ptbsales.com
 www.ptbsales.com

DATE SERVICED: _____

VIEW OUR INVENTORY



Installation, Operating & Maintenance Instructions
Series 64, DN 63-400 (I.D. 2 1/2" - 16")

Imprint:

Manufacturer VAT Vakuumventile AG, CH-9469 Haag, Switzerland

Website
www.vatvalve.com

Phone
+41 81 771 61 61

Fax
+41 81 771 48 30

Email
CH@vatvalve.com

Publisher VAT Vakuumventile AG, CH-9469 Haag, Switzerland

Editor VAT Vakuumventile AG, CH-9469 Haag, Switzerland

Print VAT Vakuumventile AG, CH-9469 Haag, Switzerland

Copyright © VAT Vakuumventile AG 2008

No part of these Instructions may be reproduced in any way (photocopies, microfilms or any other reproduction processes) nor may it be manipulated with electronic systems, duplicated or distributed without written permission from VAT. Offenders are liable to pay damages.

The original VAT firmware and updated state of the art versions of the VAT firmware are intended for use with VAT products. The VAT firmware contains a limited, time unlimited user license. The VAT firmware may not be used for purposes other than those intended nor is it permitted to make copies of the VAT firmware. In particular, it is strictly forbidden to give copies of the VAT firmware to other people.

The use of trade names, brand names, trademarks, etc. in these Instructions does not entitle third parties to consider these names to be unprotected and to use them freely. This is in accordance with the meaning of the laws and acts covering brand names and trademarks.



Contents:

1	Use of product.....	4
1.1	Technical data	4
2	Installation	5
2.1	Installation into the system	5
2.2	Connections	5
2.2.1	Tightening torque for mounting screws on flanges	5
2.2.2	Admissible forces	6
2.2.3	Compressed air connection.....	7
2.2.4	Actuator position (example).....	8
2.2.5	Compressed air connection by external solenoid (option)	8
2.2.6	Electrical connection	9
3	Operation	11
3.1	Normal operation.....	11
3.1.1	Adjustment of the intermediate position	11
3.2	Operation under increased temperature.....	12
3.3	Behavior in case of differential pressure.....	12
3.4	Behavior in case of compressed air failure.....	12
3.5	Behavior in case of power failure	12
4	Trouble shooting	13
5	Maintenance & repairs	13
5.1	Preventive maintenance.....	14
5.1.1	Procedures.....	15
6	Drawing	17
7	Spare parts	18
8	Warranty	19



1 Use of product

Use product for clean and dry indoor vacuum applications under the conditions indicated in chapter «Technical data» only! Other applications are only allowed with the written permission of VAT.

Corrosive process gases may impact the performance of the product. Please contact VAT to assure that the product is compatible with the process gases used in your application.

1.1 Technical data

Pressure range	DN 63 - 200: 1×10^{-8} mbar to 2 bar (abs) DN 250 - 400: to 1 bar (abs)
Differential pressure on the closed gate	DN 63 - 200: 2 bar in either direction DN 250 - 400: 1 bar in either direction
Max. differential pressure at opening	30 mbar
Admissible temperature: Valve	< 150°C
Actuator	< 50°C
Cycles until first service	200000
Supply voltage	see label on solenoid control valve
Power required	2 x 2,5 W
Contact rating of position indicator	5 A / 250 V AC, 3 A / 50 V DC
Compressed air pressure	4 - 7 bar / 56 -98 psi

Further data according to VAT catalogue «Vacuum Valves 2008».

2 Installation

2.1 Installation into the system

The valve seat side is indicated by the symbol:  on the connection flange.

2.2 Connections

2.2.1 Tightening torque for mounting screws on flanges

1. Mounting with centering ring

Tighten mounting screws of the flanges uniformly in crosswise order. Observe the maximum torque levels in the following table. Higher tightening torques deform the valve body and can lead to an improper function of the valve.

DN		max. tightening torque (Nm)			max. tightening torque (lbs . ft)		
mm	inch	ISO-F	JIS	ASA-LP	ISO-F	JIS	ASA-LP
63/100	4	8 – 10	8 – 10	8 – 10	6 – 8	6 – 8	6 – 8
160	6	13 – 15	13 – 15	20 – 30	9 – 11	9 – 11	15 – 22
200	8	13 – 15	13 – 15	20 – 30	9 – 11	9 – 11	15 – 22
250	10	17 – 20	17 – 20	40 – 60	13 – 15	13 – 15	30 – 44
320	12	17 – 20	17 – 20	40 – 60	13 – 15	13 – 15	30 – 44
350	14	17 – 20	17 – 20	40 – 60	13 – 15	13 – 15	30 – 44
400	16	17 – 20	30 – 35	55 – 80	13 – 15	22 – 26	41 – 59

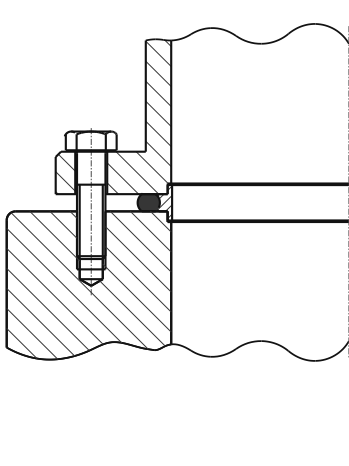

2. Mounting with O-ring in groove

Tighten mounting screws of the flanges uniformly in crosswise order. Observe the maximum torque according to the grade of screws and depth of thread you use.

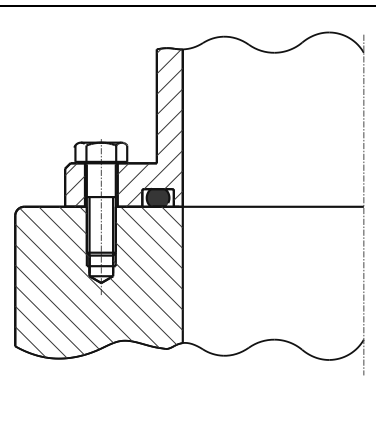

2.2.2 Admissible forces

Forces from evacuating the system, from the weight of other components, and from baking can lead to deformation of the valve body and to malfunction of the valve. The stress has to be relieved by suitable means, e.g. bellows sections. The following forces are admissible:

DN (nom. I.D.)		Axial tensile or compressive force «F _A »		Bending moment «M»	
mm	inch	N	lbf	Nm	lbf · ft
63	2 1/2	1960	440	78	58
100	4	2450	560	98	72
160	6	2940	660	147	108
200	8	2940	660	147	108
250	10	3430	770	196	145
320 / 350	12 / 14	3920	880	294	217
400	16	7840	1760	980	722

If a combination of both forces (F_A and M) occurs, the values mentioned above are invalid. Please contact VAT for more information.

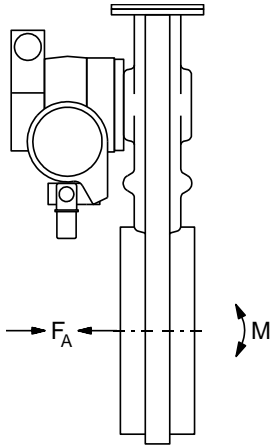

The diagram shows a cross-section of a valve stem assembly. A horizontal arrow labeled F_A points to the left, representing axial force. A curved arrow labeled M indicates a bending moment applied to the stem.

2.2.3 Compressed air connection



- Connect air pressure to inputs '1' of the solenoids (internal thread R 1/8", 1/8" NPT for USA)

Solenoid valve:

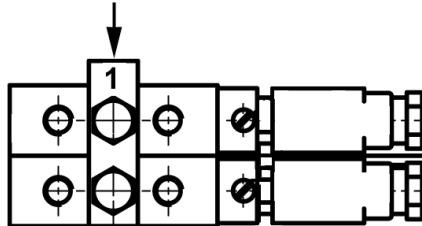

Solenoid valve for impulse actuation:

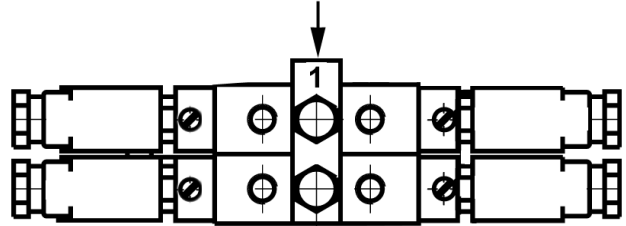

schematic:

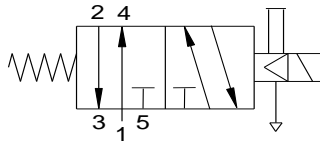

schematic:

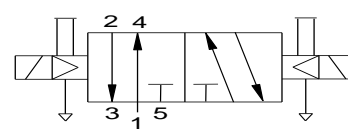

- Make sure the emergency operation screws are in remote position (fully counter-clockwise)



Note: Compressed air pressure (above atm): 4 - 7 bar / 56 -98 psi

Attention:

For proper function of the valve it is essential to use equal air pressure at OPEN -, CLOSE - and MIDDLE Pos. inlets. See table on page 6. Please consider that different solenoids, tube lengths and diameters can affect the air pressure.

- Compressed air may only be connected if
 - valve has been installed into the vacuum system
 - moving parts cannot be touched
- Use only clean, dry or slightly oiled air!
- For secure switching of solenoids, the inner diameter of the air connection tubes has to be:
 - Ø 4 mm for lengths up to 1 m
 - Ø 6 mm for lengths from 1 m to 5 m
 - Ø 8 - 10 mm for lengths above 5 m

2.2.4 Actuator position (example)

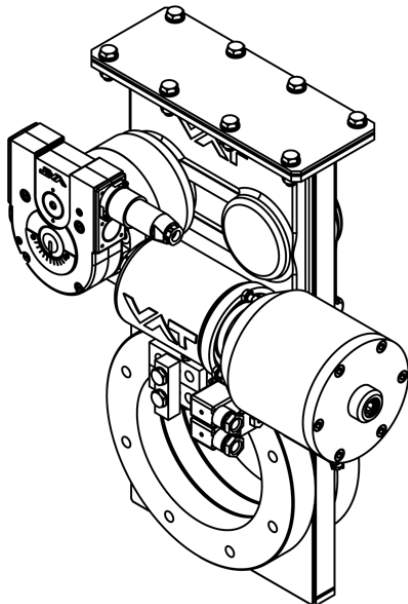

Position A (Standard)

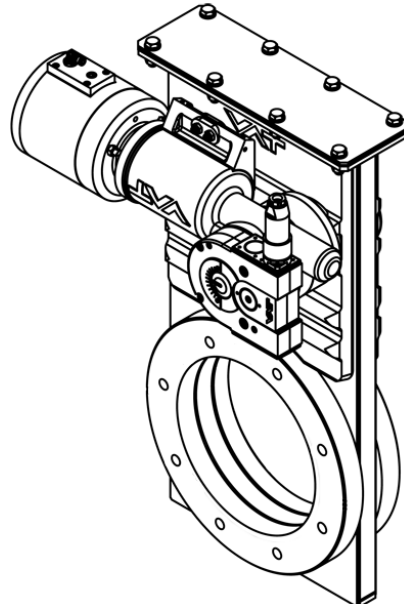

Position B (Option)

Note: For actuator position of your valve refer to the dimension diagram of your valve.

2.2.5 Compressed air connection by external solenoid (option)

Required solenoids: - Two 5/2 way valves

Air connections : - Adapter with internal thread R 1/8" (1/8" NPT for USA) mounted to the pipe thread screws 'A' and 'B' instead of the solenoids. The pipe thread screws have also the function of an orifice for air pressure reduction. They must not be removed or replaced.

- L-type connection 'C' with internal thread R 1/8" and integrated orifice for air pressure reduction (DN 63 - 200: Ø1.4 mm, DN 250 - 400: Ø1.8mm)

Apply compressed air pressure according the following table:

Actuator on „A-position“ (Standard)	A	B	C
open position	1	0	0
intermediate position	1	0	1
closed position	0	1	1/0
Actuator on „B-position“ (Option)	A	B	C
open position	0	1	1/0
intermediate position	1	0	1
closed position	1	0	0
1 = air pressure 0 = no air pressure			

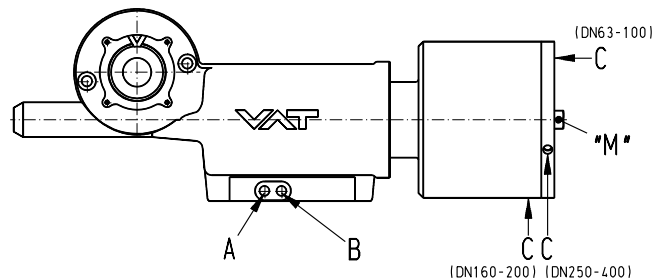

2.2.6 Electrical connection

Verify that mains voltage matches voltage stated on the solenoid! Sockets for position indicator and solenoid are supplied with the valve.



Do not touch electrical parts under voltage!



Electrical power may only be connected if:

- valve has been installed into the vacuum system
- moving parts cannot be touched

Wire solenoid and position indicator according to the following diagrams.

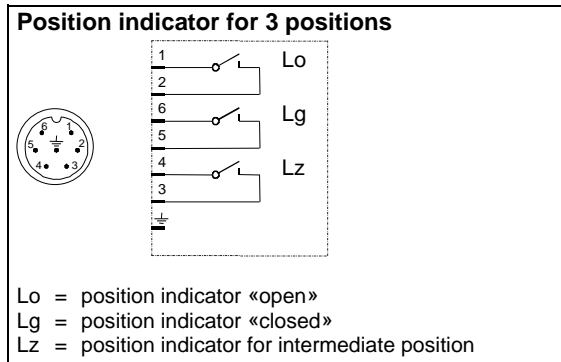
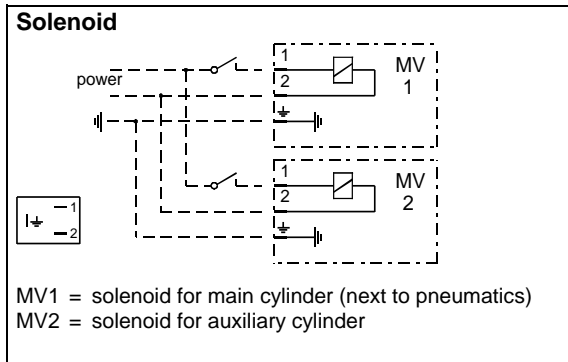

Control logic for actuator on valve seat side (A-side)	MV1	MV2
open position	+	+
intermediate position	+	-
closed position	-	-
+ = solenoid coil supplied with current - = solenoid coil not supplied with current		

Control logic for actuator on valve seat side (B-side)	MV1	MV2
open position	+	+
intermediate position	-	+
closed position	-	-
+ = solenoid coil supplied with current - = solenoid coil not supplied with current		

Solenoid for impulse actuation (option)

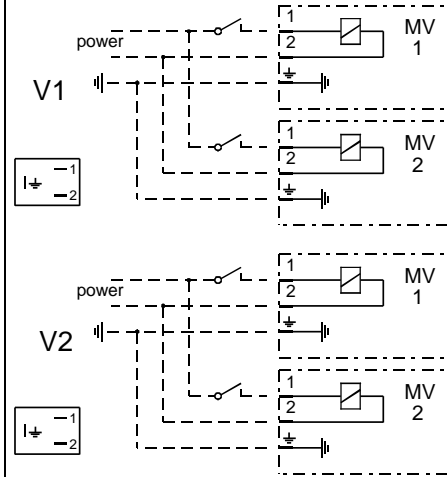

V1 = impulse solenoid for main cylinder
(next to pneumatics)
V2 = impulse solenoid for auxiliary cylinder
MV1 = solenoid coil for opening
MV2 = solenoid coil for closing

- To open energize the solenoids MV1 of V1 and V2 simultaneously
- To close energize the solenoids MV2 of V1 and V2 simultaneously
- To throttle energize the solenoids MV1 of V1 and MV2 of V2 simultaneously

Actuator on A side	V1		V2	
	MV 1	MV 2	MV 1	MV 2
open position	+	-	+	-
intermediate position	+	-	-	+
closed position	-	+	-	+
+ = solenoid coil supplied with current - = solenoid coil not supplied with current				

Actuator on B side (solenoid turned 180 °)	V1		V2	
	MV 1	MV 2	MV 1	MV 2
open position	+	-	+	-
intermediate position	-	+	+	-
closed position	-	+	-	+
+ = solenoid coil supplied with current - = solenoid coil not supplied with current				

3 Operation

3.1 Normal operation

Operation is allowed only after proper installing procedure.

3.1.1 Adjustment of the intermediate position

The intermediate position can be adjusted (allen wrench 8mm) independently of the air pressure by means of the bolt screw 'M' (see also page 7 and picture below), on the face side of the auxiliary cylinder. Before moving the bolt screw 'M', open the locking screw (B) (allen wrench 2.5mm). After adjustment the intermediate position, fasten the locking screw (B).

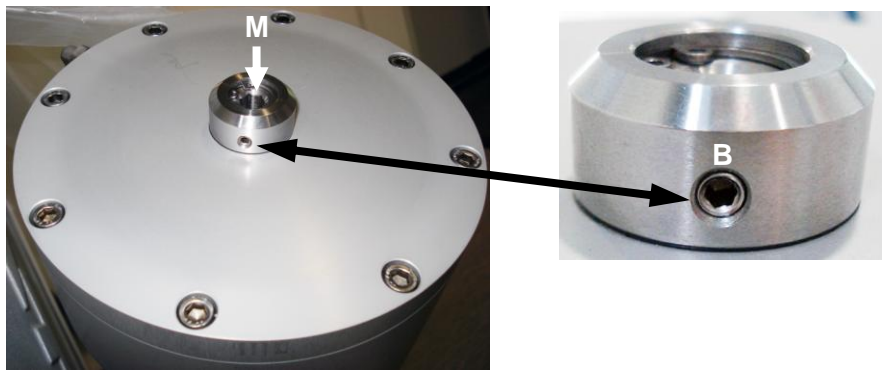

For easy adjustment, VAT is recommending to switching off the compressed air during adjustment of the intermediate position.

A-side actuator: turning bolt screw 'M' clockwise moves the intermediate position to open
 B-side actuator: turning bolt screw 'M' clockwise moves the intermediate position to close

The position indicator on the valve can be adjusted for the set intermediate position. Move valve with bolt screw 'M' to the desired position and then turn the screw (A) with a screwdriver size 2 on top of the position indicator box in either direction until the microswitch Lz switches. (Lz = position indicator for intermediate position)

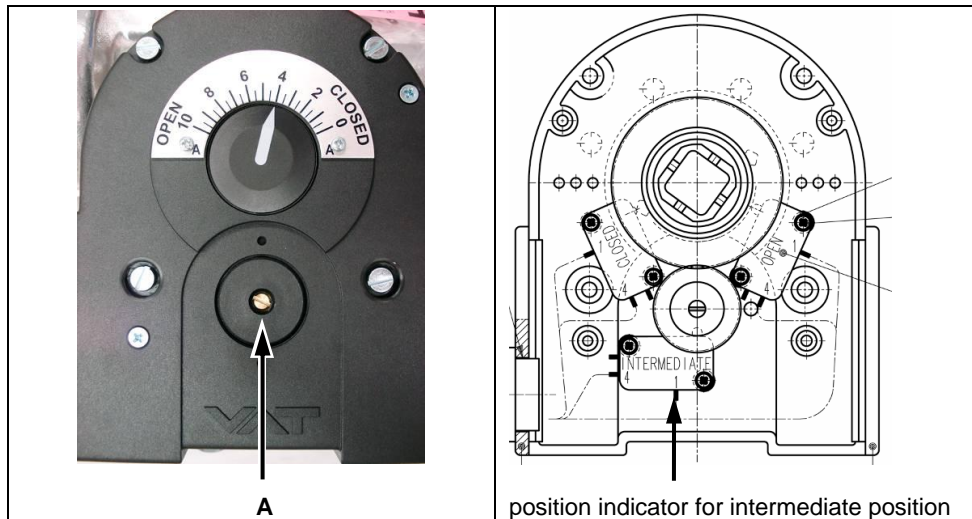

3.2 Operation under increased temperature

See «1.1 Technical data»

3.3 Behavior in case of differential pressure

Note: Do not open the valve, if the differential pressure on the gate is larger than 30 mbar.

3.4 Behavior in case of compressed air failure

Valve closed: valve stays closed and leaktight

Valve open or Intermediate position: valve stays open or moves into closed (not leaktight) position, depending on the mounting position

3.5 Behavior in case of power failure

Standard solenoids: valve closes

Impulse solenoids: valve moves to the position of last command and stays in this position

The solenoids can be actuated manually in case of power failure according to the following instructions:

Standard solenoid valve

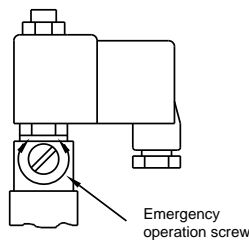

To open the valve:

Turn emergency operation screw fully clockwise

To close the valve:

Turn emergency operation screw fully counter-clockwise

Attention!

Remote operation is only possible when the screw is turned fully counter-clockwise

Solenoid for impulse actuation (option)

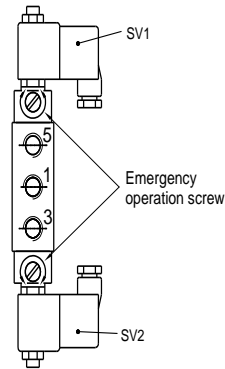

To open the valve:

Turn emergency operation screws of coils «SV1» clockwise to mechanical stop. Turn back emergency operation screws counter-clockwise as soon the valve is open

To close the valve:

Turn emergency operation screws of coils «SV2» clockwise to mechanical stop. Turn back emergency operation screws counter-clockwise as soon the valve is closed

Attention!

Remote operation is only possible when both screws are turned fully counter-clockwise

4 Trouble shooting

Failure	Check	Action
Valve does not close/open/control	<ul style="list-style-type: none"> • Compressed air? • Electrical connection? • Differential pressure • Mechanical parts blocked? 	<ul style="list-style-type: none"> • Check compressed air at solenoids • Is differential pressure < 30 mbar? • Do not operate valve, while differential pressure is > 30 mbar. Equalize pressure first. • Is valve cable connected properly? • Mechanical parts blocked? (cleaning)
Leak at gate	<ul style="list-style-type: none"> • Sealing surface gate • Gate • O-ring 	<ul style="list-style-type: none"> • Clean valve seat and gate! • Check surface of seat and O-ring • Change O-ring, if necessary
Leak at body	Leak check	<ul style="list-style-type: none"> • Flange seals leaktight? • Bonnet seal leaktight? • Screws at bonnet tightened properly?

If you need any further information, please contact one of our service centers. You can find the addresses on our website: <http://www.vat.ch>

5 Maintenance & repairs

Under clean operating conditions, the valve does not require any maintenance during the specified cycle life. Contamination from the process may influence the function and requires more frequent maintenance.

Before carrying out any maintenance or repairs, please contact VAT. It has to be individually decided whether the maintenance/repair can be performed by the customer or has to be carried out by VAT. The fabrication number on the valve

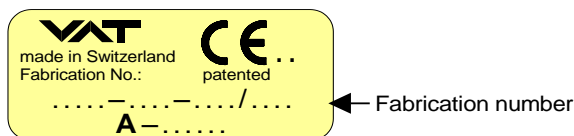

has always to be specified.

All supplies (e. g. compressed air, electrical power) must be disconnected for removal/installation of the valve from/into the system and for maintenance work.



Even with disconnected supply, loaded springs and/or air cushions in cylinders can be potential hazards.



Keep fingers and objects away from the valve opening!



Products returned to VAT must be free of harmful substances such as e.g. toxic, caustic or microbiological ones. If products are radioactively contaminated, fill in the VAT form «Contamination and Radiation Report» and send it with the product. The form is available at VAT. The maximum values indicated in the form must not be exceeded.

5.1 Preventive maintenance

The numbers in brackets refer to the drawing on page 17.

Note! The process environment of your application (i.e. corrosive gases, deposition on parts inside valve body) may suggest shorter preventive maintenance intervals than suggested below.

Baking of the valve is highly recommended for contaminating processes. VAT offers customized heater box for series 64 valves.

For quick maintenance, VAT recommends to exchange the complete gate assembly in order to reduce the downtime of the system.

Warning! DN 160 – 400: Never remove the striking plate (22) of the ball guidance (18)!

Recommended maintenance after every 100'000 cycles (after 50'000 cycles for DN 400)

- Clean gate O-ring (or to replace it, if necessary), clean the inside surfaces
- Inspect the bonnet seal and inspect ball bearings and crank bolt
- Replace all parts which are per process caused corrosion or material pollution (recommended spare parts kit 'C')

Recommended maintenance after every 200'000 cycles (after 100'000 cycles for DN 400)

Additional to the 100'000 cycles maintenance interval, VAT recommends to clean and lubricate the ball bearings (replace it, if necessary), replace the locking balls, replace the crank bolt, inspect, clean and re-lubricate the ball guide plate (replace it if the balls have seized in the bushings), inspect, clean and re-lubricate the feedthrough O-ring (replace it if necessary)

The following table refers to the procedures in the following chapter and the spare parts list on page 17.

Cycles *)	Procedures	Recommended spare parts kits
Every 100'000	1., 2., 3.	A, E For individual items see spare parts list on page 8
Every 200'000	1., 2., 3., 4., 5., 6., 7.	B, C, E For individual items see spare parts list on page 8

*) Definition of a cycle: Movement of the gate from open into closed or control position and back into open position



5.1.1 Procedures

1. Precondition for all maintenance work

- Vent both valve chambers
- Open gate valve
- Shut off air supply and electrical power
- Disconnect all cables to the actuator

2. Removal of the gate assembly (4) / Replacement of the crank bolt (6) / Replacement of the bonnet seal (3)

- Unfasten the bonnet screws (1)
- Remove the bonnet plate (2) and the bonnet seal (3)
- Pull the lever (17) a little bit out of the bonnet opening
- Loosen the hexagonal socket-head bolt (7) for the crank bolt (6)
- Remove the crank bolt (6), while lifting the gate assembly (4) a little bit if necessary
- Slide out the gate assembly (4) carefully from the body and put it on a clean workshop place
- Re-assemble in reverse direction
- Fasten the screws (1) crosswise with equal torque: ≈ 14 Nm (10 lbf ft) with DN 63 - 100
 ≈ 18 Nm (13 lbf ft) with DN 160 - 400

3. Replacement of the gate O-ring (5)

- Put a suitable tool beneath the O-ring at the venting hole and lift the O-ring carefully out of the groove (take care that the groove will not be damaged)
- Clean groove and sealing surface
- Install new O-ring by pressing it crosswise uniformly into the groove. Make sure, the O-ring is not twisted (pay attention to the seam of the O-ring)

4. Replacement of the ball bearings (24)

- DN 63, DN 160 - 200: Replace the complete ball bearing assembly (DN 63: 1 pc, DN 160 - 200: 2 pcs)
- DN 100, DN 250 - 400: Replace each single ball bearing and pull out the its centre ring (4 pcs)

5. Replacement of the locking balls (21)

- Put the gate assembly (4) carefully on a clean workshop place with the O-ring side to the bottom
- DN 63: Push center spring down and dismount two-piece circlip from the center bearing. Lift off ball guide plate
- DN 100 - 400: Unscrew the hexagonal nuts (19). Lift off counter plate (20) and ball guide plate (18)
- Remove the locking balls (21)



6. Replacement of actuator

- Close and lock valve
- Remove the position indicator box (8) from the actuator and unscrew the 2 hexagon bolts of the actuator
- Pull off actuator from the gear wheel of the feedthrough assembly (9). Take hold of the actuator on both sides of the actuator flange and use your thumb to push against the shaft of the feedthrough
- Make sure that rack of the actuator is in closed position
- Check whether valve is closed and properly locked
- Set up actuator on gear wheel and shaft in a right angle to the valve. If the actuator cannot engage with the gear wheel, turn actuator under little pressure a few degrees counter-clockwise until it engages with the gear wheel
- For change into position A2 or B2, first unscrew the 2 hexagonal bolts of the feedthrough assembly and put them into the bolt holes in the lateral axis
- Turn the actuator slightly back to the right angle position so that the 2 bolts can fit loosely in the threaded holes
- Fasten the 2 bolts only when flange area of the actuator lies tightly on the actuator flange of the valve
- Set position indicator box (8) on actuator
- Align position indicator so that the 4 cylinder head screws will fit loosely in the threaded holes. Fasten screws
- Verify the correct adjustment of the position indicator. In the position where the microswitch has switched, the valve must be closed and locked

7. Replacement of feedthrough O-ring (11)

- Remove gate assembly (4) as per items 1 and 2
- Remove actuator as per item 6
- Push the roll pin (12) out of the feedthrough shaft. Use VAT feedthrough assembling tool or a punch. Remove lever (17).
- Loosen the 2 screws of the feedthrough assembly (9)
- Slide out complete feedthrough assembly (9), carefully dismantle feed through assembly and remove the feedthrough O-ring (11)

6 Drawing

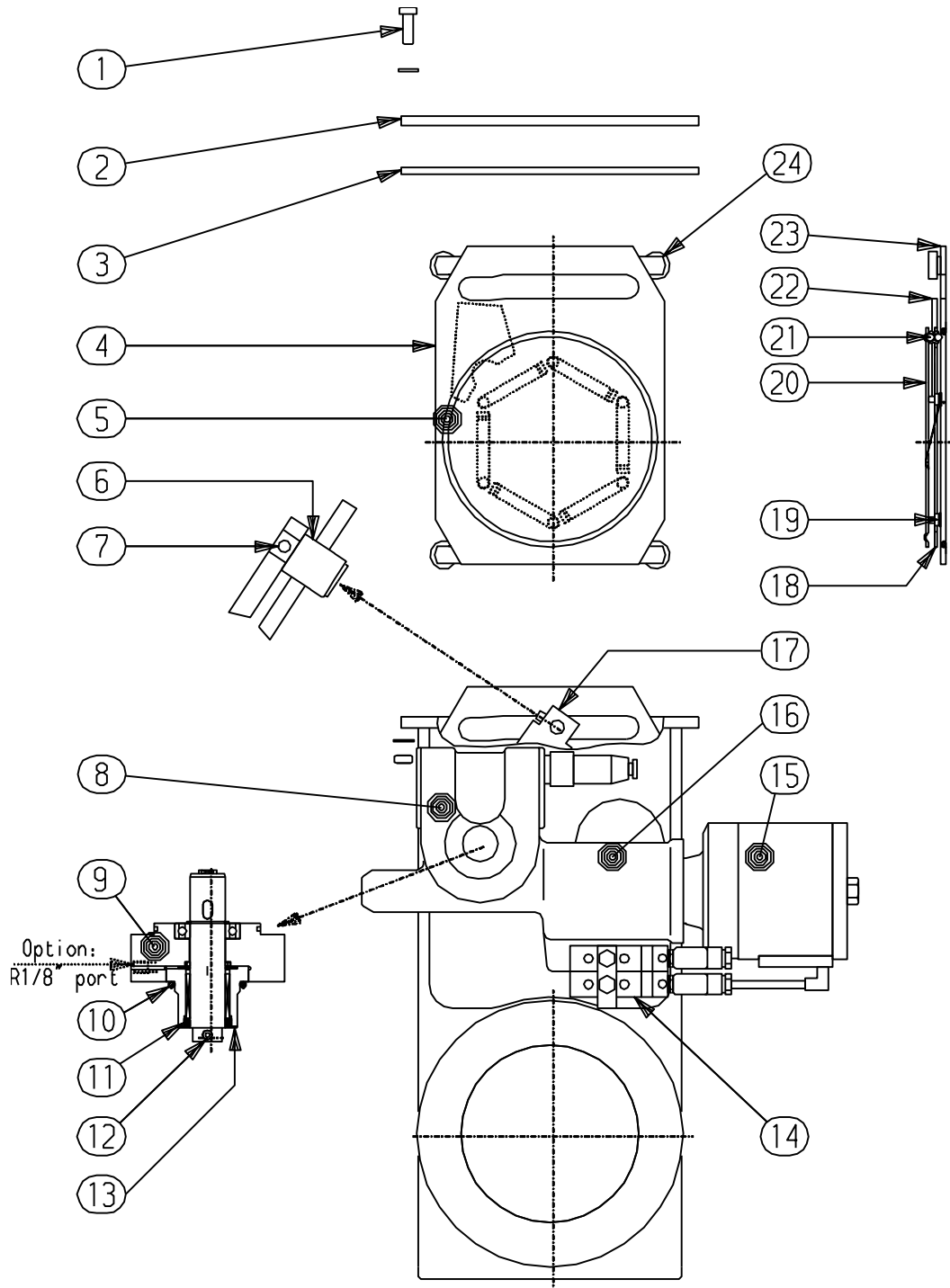

7 Spare parts



Please specify the **fabrication number of the valve** (see yellow label on valve) when ordering spare parts. This is to ensure that the appropriate spare parts are supplied.

The item numbers refer to the assembly drawing on page 17

Item	Description	DN 63	DN 100	DN 160	DN 200	DN 250	DN 320 DN 350	DN 400
3	Bonnet seal	77775-R1	77778-R1	77781-R1	77784-R1	N-5100-378	N-5100-382	N-5100-383
4	Gate assembly	89146-R1	94842-R1	84275-R1	84608-R1	83481-R1	409173	215561
5	Gate O-ring	N-5102-340	N-5102-351	N-5102-364	N-5100-372	N-5102-453	N-5102-457	N-5100-461
6	Crank bolt	79090-R1	79090-R1	79090-R1	79090-R1	85783-R1	85783-R1	87749-R1
7	Crank bolt mounting screw with spring washer	N-6005-458 N-6162-405	N-6005-458 N-6162-405	N-6005-458 N-6162-405	N-6005-458 N-6162-405	N-6005-502 N-6162-407	N-6005-502 N-6162-407	N-6005-502 N-6162-407
9	Feedthrough assembly	96443-R1	96443-R1	95937-R1	95937-R1	96444-R1	96444-R1	96452-R1
12	Feedthrough connection pin	N-6097-478	N-6097-478	N-6097-480	N-6097-480	N-6097-509	N-6097-509	N-6097-509
	3-position pneumatic actuator, consisting of							
	- pneumatic actuator (16)	83580-R1	83580-R1	83581-R1	83581-R1	83582-R1	83582-R1	83582-R1
	- 3-position pneumatics (15)	230400	230400	226400	226400	230600	230600	230600
	- solenoid set (14)	234418	234418	84476-R1	84476-R1	83586-R1	83586-R1	237670
	- position indicator (8)	60550-R1	60550-R1	60550-R1	60550-R1	60550-R1	60550-R1	60550-R1
10	Static actuator seal	N-5100-222	N-5100-222	N-5100-225	N-5100-225	N-5100-228	N-5100-228	N-5100-228
11	Feedthrough O-ring (option R 1/8" port: 2 pcs)	N-5100-316	N-5100-316	N-5100-319	N-5100-319	N-5100-322	219930	N-5100-322
21	Locking balls	N-6121-052 (8 pcs)	N-6121-052 (12 pcs)	N-6121-051 (18 pcs)	N-6121-051 (24 pcs)	N-6121-081 (18 pcs)	N-6121-081 (24 pcs)	N-6121-097 (32 pcs)
24	Ball bearing assembly	66856-R1 (1 pc)	67064-R1 (2 pcs)	84326-R1 (2 pcs)	80642-R1 (2 pcs)	99205-R1 (4 pcs)	99205-R1 (4 pcs)	77286-01 (4 pcs)
A	Seal kit vacuum	97442-R1	97446-R1	85047-R1	95939-R1	98472-R1	98474-R1	98476-R1
B	Actuator replacement kit, consisting of: actuator seal, bonnet seal, feedthrough O-ring, feedthrough connection pin	101036-R1 (+static actuator seal)	101037-R1 (+static actuator seal)	88720-R1	88721-R1	88722-R1	88723-R1	88724-R1
C	Gate spare parts kit, consisting of: gate O-ring, crank bolt, crank bolt mounting screw with spring washer, ball bearings, locking balls	101038-R1 (no ball bearings and locking balls)	101039-R1 (no ball bearings and locking balls)	88725-R1	88726-R1	88727-R1	88728-R1	88729-R1
D	Feedthrough assembling tool	91001-R1				227400		
E	VAT vacuum grease (40g)	N-6951-012						



8 Warranty

Each product sold by VAT Vakuumventile AG (VAT) is warranted to be free from the manufacturing defects that adversely affect the normal functioning thereof during the warranty period stated in VAT's «Terms of Sale» immediately following delivery thereof by VAT, provided that the same is properly operated under conditions of normal use and that regular, periodic maintenance and service is performed or replacements made, in accordance with the instructions provided by VAT. The foregoing warranty shall not apply to any product or component that has been repaired or altered by anyone other than an authorized VAT representative or that has been subject to improper installation or abuse, misuse, negligence or accident. VAT shall not be liable for any damage, loss, or expense, whether consequential, special, incidental, direct or otherwise, caused by, arising out of or connected with the manufacture, delivery (including any delay in or failure to deliver), packaging, storage or use of any product sold or delivered by VAT shall fail to conform to the foregoing warranty or to the description thereof contained herein, the purchaser thereof, as its exclusive remedy, shall upon prompt notice to VAT of any such defect or failure and upon the return of the product, part or component in question to VAT at its factory, with transportation charges prepaid, and upon VAT's inspection confirming the existence of any defect inconsistent with said warranty or any such failure, be entitled to have such defect or failure cured at VAT's factory and at no charge therefor, by replacement or repair of said product, as VAT may elect. VAT MAKES NO WARRANTY OR REPRESENTATION OF ANY KIND, EXPRESS OR IMPLIED, (INCLUDING NO WARRANTY OR MERCHANTABILITY), EXCEPT FOR THE FOREGOING WARRANTY AND THE WARRANTY THAT EACH PRODUCT SHALL CONFORM TO THE DESCRIPTION THEREOF CONTAINED HEREIN, and no warranty shall be implied by law.

Furthermore, the «Terms of sale» at the back of the price list are applicable.