



FOR SALES AND SERVICE PLEASE CALL:

PTB SALES

T :: 626.334.0500
service@ptbsales.com
www.ptbsales.com

DATE SERVICED: _____

ADP/ADS User's manual

VIEW OUR INVENTORY

A - Introduction

■ ADP/ADS Series One	A 10
■ The various versions of ADP Series One	A 20
■ ADP/ADS Serie One Dry pumps for semi-conductor's industry	A 30
■ Types of monitoring systems	A 40
■ Dry pump operational principle	A 50
■ The accessories	A 60
■ Technical characteristics.....	A 70

B - Start-up

■ Safety instructions	B 00
■ Unpacking / Storage	B 10
■ Positioning the pump in pumping installation	B 20
■ Installing anti-vibration pads.....	B 30
■ Modular version - Layout	B 40
■ Filling the pump oil housings	B 50
■ Connection to the cooling circuit	B 60
■ Inert gas purge connection (N2 plug)	B 70
■ Nitrogen purge flow sensor	B 80
■ Connection to the pumping circuit	B 90
■ Electropneumatic exhaust valve connection (withdrawal)	B 100
■ Pump power supply	B 110
■ Water flowrate and gas purge according to processes... ..	B 120
■ Checking the rotational direction	B 130
■ Remote control plug connection (M3 monitoring)	B 140
■ Remote control plug connection (M1 monitoring)	B 141
■ RS 232 or RS 485 link wiring	B 150
■ Use of the Serial link (Service centers)	B 160
■ Installation of silencer heating kit	B 170

Edition 04 - May 98

ADP/ADS User's manual

C - Operation

■ Start-up of the M3 monitoring system.....	C 10
■ Setting the M3 monitoring system parameters	C 20
■ M3 Monitoring system function table.....	C 30
■ Use of the M3 monitoring system	C 40
■ Use of the M1 monitoring system	C 50

D - Maintenance

■ Safety instructions related to maintenance	D 00
■ First level of maintenance.....	D 10
■ Maintenance frequency.....	D 20
■ Diagnosis and troubleshooting	D 30
■ Pump does not start	D 40
■ The pump is running and then is showing an alert or alarm message (followed by pump stopping) .	D 50
■ Pump is running - No message	D 60
■ «Breaker ...» Alarm	D 70
■ «Pressure»/«Purge N2» Alert and alarm	D 80
■ «Gas temp.» Alert	D 90
■ «Pump temp.» Alert	D 91
■ «Consumption» Alert and alarm	D 100
■ «Water flow» Alert	D 110
■ «Motor temp.» Alert or alarm.....	D 120
■ «Analogic input» Alert or alarm.....	D 130
■ «E1 logic»/«E2 logic» Alert or alarm	D 140
■ «Valve option» Alert and alarm	D 150
■ «Variator» Alarm.....	D 160

ADP/ADS User's manual

E - Maintenance instructions

■ Maintenance precautions (Service centers)	E 10
■ Pump draining	E 20
■ Silencer maintenance	E 30
■ Electropneumatic valve maintenance (withdrawal)	E 40
■ Freeing up the ADP	E 50

Safety instructions concerning product installation, operation and maintenance.

Our ALCATEL products are designed and tested to provide maximum safety. However, in order to obtain the best level of safety, the following must be observed:

- the user's manual during product transport, installation, operation and maintenance.
- the safety instructions signalled with the following symbol:

Symbol



Meaning

Users of this equipment should be alert to level of hazards identified by this symbol.

Warnings are used when failure to observe instructions or precautions could result in significant damage to equipment, and/or in injury to humans.

ADP/ADS Series One dry pumps

Dear Customer,

you have just purchased an Alcatel dry pump. We thank you and are proud to include you in our customers.

This product has benefited from Alcatel's many years of experience in "semiconductor" processes and dry pumping.



For optimum performance and to obtain full satisfaction from this equipment, we recommend that you study this manual before any intervention on your pump, in particular, the chapter on installation and start up.

MANUAL REFERENCE : 100 448
EDITION : 04 - May 1998

APPLICATIONS :

- ALL "SEMICONDUCTORS" PROCESSES
Stripping, Etching, PECVD, LPCVD, MOCVD, Epitaxy, ...
- SCIENTIFIC RESEARCH

ADVANTAGES :

Easily adaptable to processes - Tested design - Vertical pumping - Clean room compatible - Advanced monitoring system functions - Low noise level - Low operating cost - Easy maintenance and repairs - Anti-vibration frame - Compact.

SPECIAL FEATURES :

Multi-stage Roots technology - water-cooled multi-voltage motors - built-in monitoring system (remote optional) - anti-dust, sound-proof aesthetic covers, easily removed - incorporated purge line (N₂) - Quick connection - Modular design and interchangeable parts - Easy to transport - Network compatible.

ADP/ADS Series One



Multi-stage pump with Roots technology

- well-known technology
- reliability

Sealed motor with liquid cooling

- no fan (clean room compatible)
- safe : no gas leak
- quiet
- multi-voltage, bi-frequency 50/60 Hz

Genuinely dry pump

- **guaranteed by design**
 - **guaranteed by testing**
- Residual gas spectrum free from hydrocarbon peaks

Vertical pumping

Reliability Easy maintenance

- MTBF > 50 000 hours
- interchangeable parts
 - may be performed by user

Pump designed for all processes

- Several equipments are available for semi-conductor's applications, corrosives, CVD or clean processes

2 versions

- Standard or modular

The various versions of ADP/ADS Series One

Standard version

The Standard Series pumps are fully integrated in a compact and covered frame which includes: the monitoring system, the flowmeter panel, the facilities panel, an OEM interface panel and the RS 232/485 serial link.

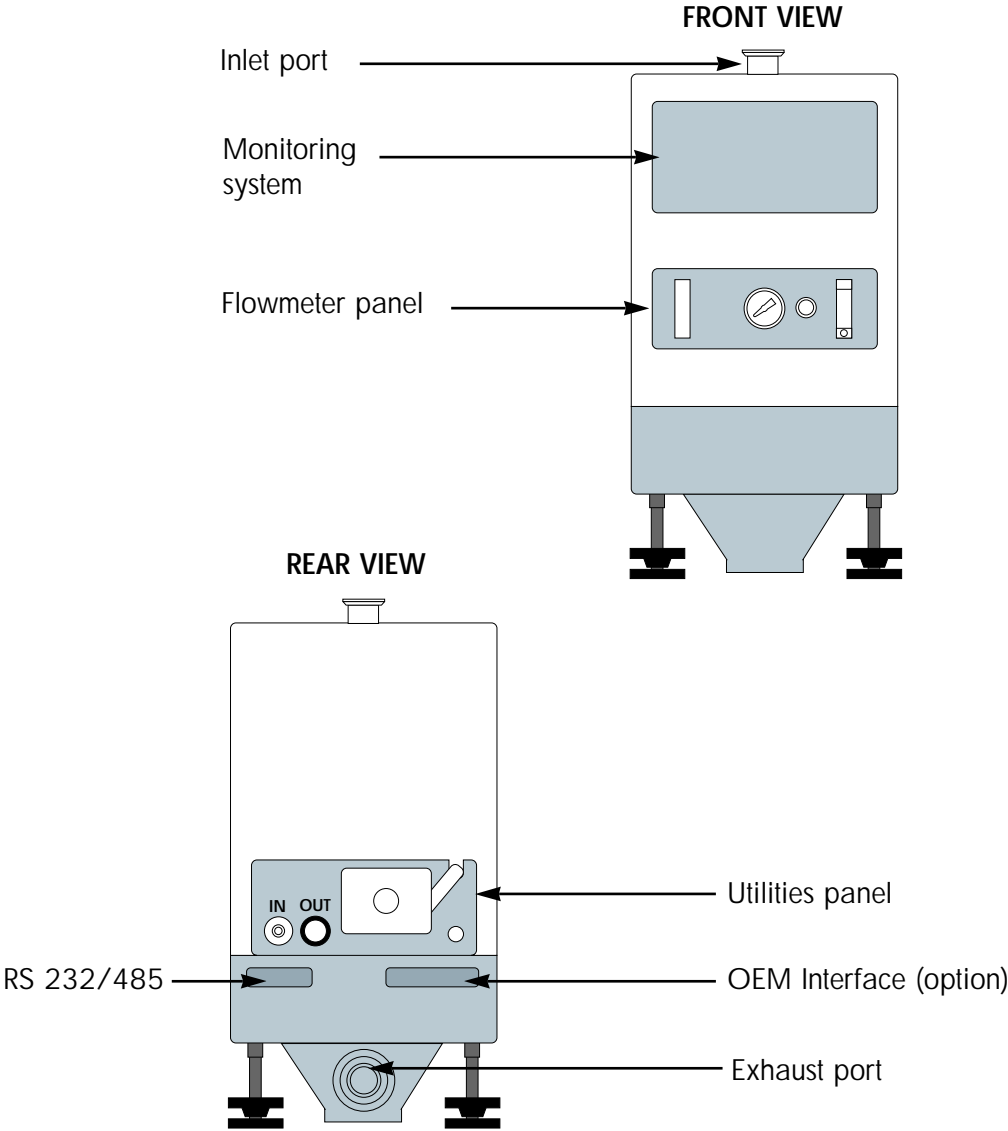

Edition 03 - May 97

The various versions of ADP/ADS Series One

Standard version (continued)

1 - PUMPING SYSTEMS : ADP or ADS*

* In an ADS, a Roots pump is combined with an ADP.

2 - Silencer with check valve function

3 - Compact frame

May be equipped with anti-vibration pads.

4 - Utilities panel with Quick Connectors for all utilities :

Water, gas purge, power.

5 - Two types of monitoring system : M1 or M3 integrated

The monitoring system M1 may be remote (optional).

6 - Flowmeter panel

with water and purge gas flow rate settings.

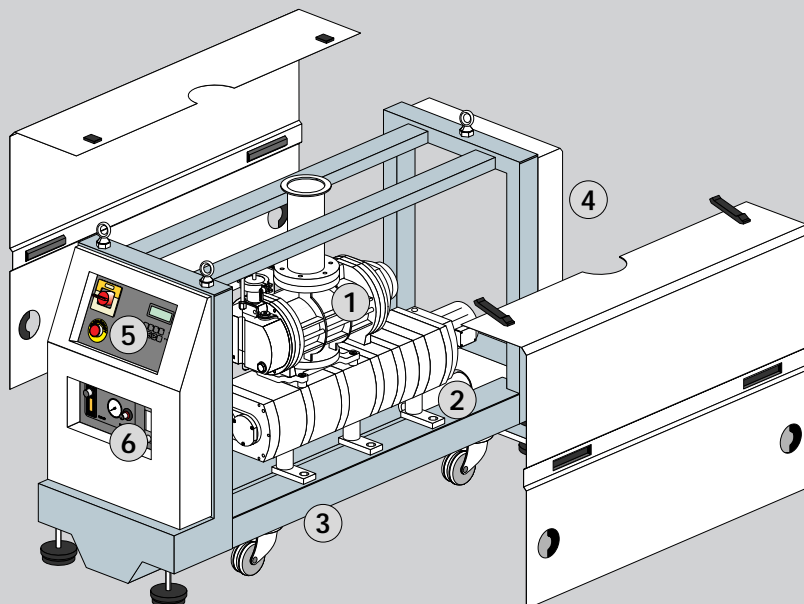

The various versions of ADP/ADS Series One

Modular Version

For specific uses,
Alcatel has developed
a modular version from
the series One
which offers in addition
of standard version
the following characteristics

- Footprint and volume minima
- Total flexibility of use due to its modular possibilities of installation
- No cover for easy integration
- Guaranteed accessibility for preventive maintenance and repair.



The "MD" Series is composed of a pumping unit on its frame and various modules :

- Flowmeter panel (gas purge and cooling water)
- Utilities panel (gas purge and cooling connections)
- Electrical box including monitoring (M1 or M3)
- OEM interface panel / Remote control

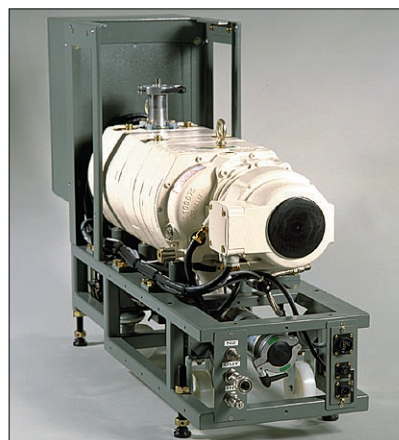

By design, these modules can be fitted to the pump frame in the best suitable position chosen by the user.

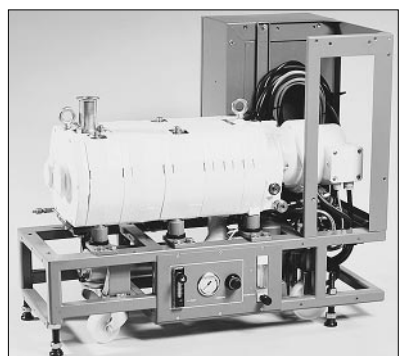

Apart from its mounting in the different possible positions on the pump frame, the electrical box can be set remote to 5 meters from the pump if necessary.

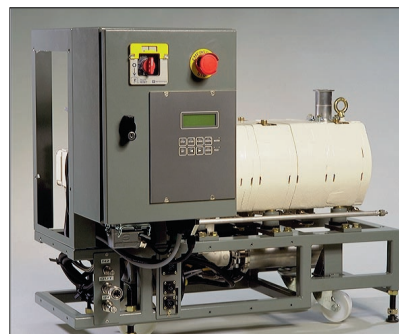

ADP/ADS Series One dry pumps for semi-conductor's industry

The ADP / ADS range is designed for three types of applications :

Clean processes

This concerns all applications for clean pumping (particle-free) and non-corrosive gases (load lock pumping for example). No nitrogen purge needed.

ADP 31/ADP 81 ADS 151/301/501 equipment

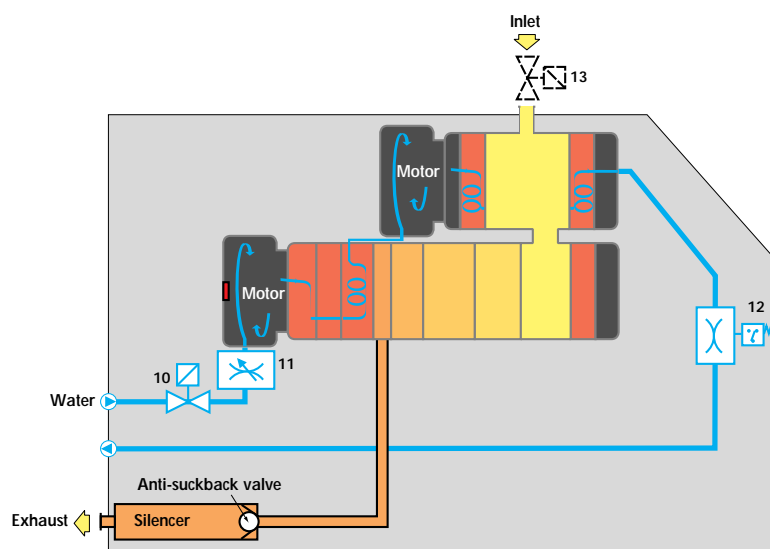

10 - Water electrovalve

11 - Water flowmeter

12 - Water flow sensor

13 - Isolation valve (accessory)

ADP/ADS Series One dry pumps for semi-conductor's industry

Corrosive processes

This concerns all applications for pumping chlorinated, fluorinated, crystallizable or condensable gases, (for example : ion implantation, etching, epitaxy...). This version contains a nitrogen injection system in all the pump's stages.

The nitrogen injection system

It is used to help evacuate pollutants produced by the process, dilute the harmful gases present in the compression stages and protect the mechanical parts of the pump.

Gas injection at the different stages of the pump :

The neutral gas (usually nitrogen) injection system is used to decrease the concentration of process gases and the condensation of gases in the pump.

ADP 31/ADP 81 ADS 151/301/501 equipment

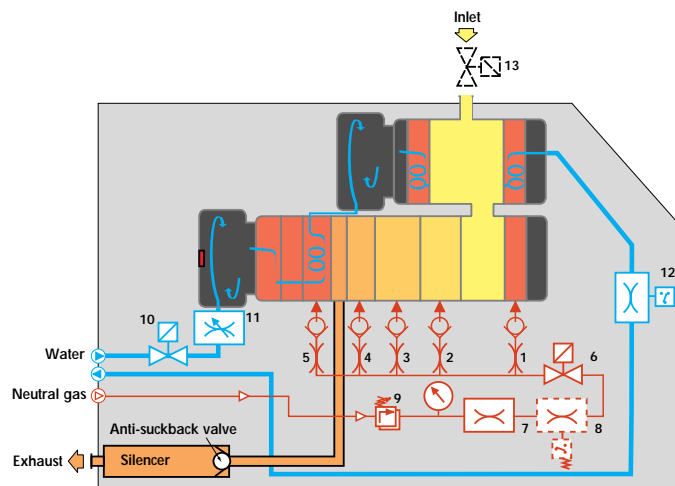

1 - LP1 2 - LP2 3 - LP3 4 - HP4 5 - HP5 :
Gas injection (calibrated jets with valves)

6 - Gas electrovalve 7 - Gas flowmeter
8 - N2 flow sensor (optional) 9 - Pressure regulator

Cooling system:
10 - Water electrovalve 11 - Water flowmeter
12 - Water flow sensor

Accessories:
13 - Isolation valve

ADP/ADS Series One dry pumps for semi-conductor's industry

Very corrosives processes "TC" CVD type

Several models are available for the CVD processes which are generating lots of quantities of particles and condensable gases (BPSG, TEOS, LPCVD nitride...). Compared to the previous version, the main differences are the following:

- nitrogen injection and cooling circuit are optimized to avoid deposition and condensation.
- ADP temperature controlled device.
- extra protections of ball bearings against process particulates are used in ADP and Roots.

Note : The "TC" version (Temperature Controlled) includes an optimized cooling circuit and a temperature regulation on the ADP. These functions can be installed on equipment for corrosive processes without CVD option.

ADP 81/ ADS 151/ 301/501/801/1001 equipment

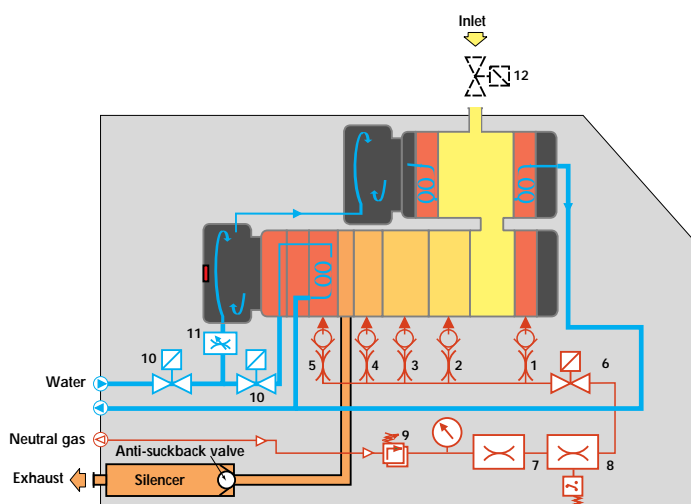

1 - LP1 2 - LP2 3 - LP3 4 - HP4 5 - HP5 :
Neutral gas injection

6 - Shut-off valve 7 - Gas flowmeter
8 - N2 flow sensor (option) 9 - Pressure regulator

Cooling system:
10 - Water electrovalve 11 - Water flowmeter

Accessories:
12 - Isolation valve

N2 flow sensor (optional)

This sensor (8) is used to warn the user when the N₂ flow comes under a preset value during harsh processes (SiH₄ for example).

Types of monitoring systems

2 types of monitoring system

M1 Solid-state monitoring without neutral gas control,
M3 monitoring driven by a microprocessor .

Monitoring system M1

Parameters monitored :

- Water flow failure
- Electrical overloading

Monitoring system M1 can be remote controlled.



M1 Remote monitoring system

This is a unit separated from the frame (5 or 10 meters cable) for the remote control and monitoring of the pump.



5 or 10 meters

Monitoring system M3

- Monitoring system controlled by microprocessor
- LCD display of parameters and messages
- Memorization of the 10 latest alerts and alarms
- RS 232 - RS 485 - NETWORK links



This monitoring system can directly be interfaced with most of the production equipments.

Parameters monitored :

- Water flow failure
- Purge flow failure
- Electrical overloading
- Purge flow and exhaust pressure
- Exhaust gas temperature
- ADP motor power
- Water flow rate
- Maintenance Time

Dry pump operational principle

Multi-stage Roots principle

The ADP pump consists of 5 Roots type stages. The two rotors rotate without touching each other.

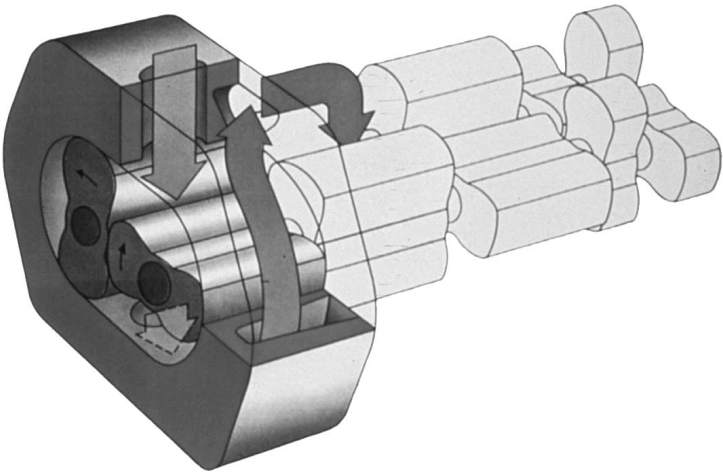

The three stages on the low pressure side are called "LP stages" and the two stages on the high pressure side are called "HP stages".

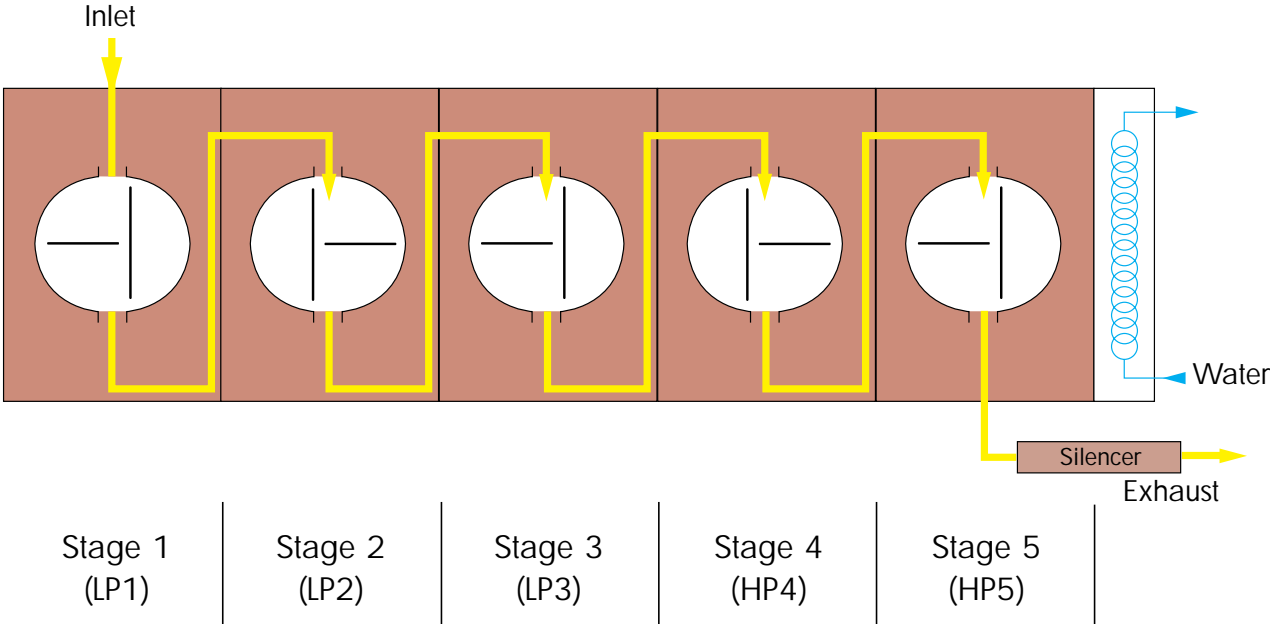

Edition 03 - May 97

Dry pump operational principle

Tightness with environment

Tightness at low pressure side

The pump bearings on the low pressure side are fitted with ceramic ball bearings lubricated with fluorinated grease which resists high temperatures and the possible corrosion due to the application.

An overpressure zone is created around the bearing by injecting a neutral gas (Purge LP1). The grease works in a less severe vacuum and thus lasts longer.

This pressurization also prevents pumped gases from migrating towards the bearings.

Neutral gas purging for the bearings is imperative for corrosive processes.

Tightness at high pressure side

The bearings are lubricated by oil splashing.

The oil sump is sealed from stage HP₅ by a trap and a deflector.

This trap is also used :

- as a **heat barrier**
- as a **pumped gas barrier**
- to **recover fluid**

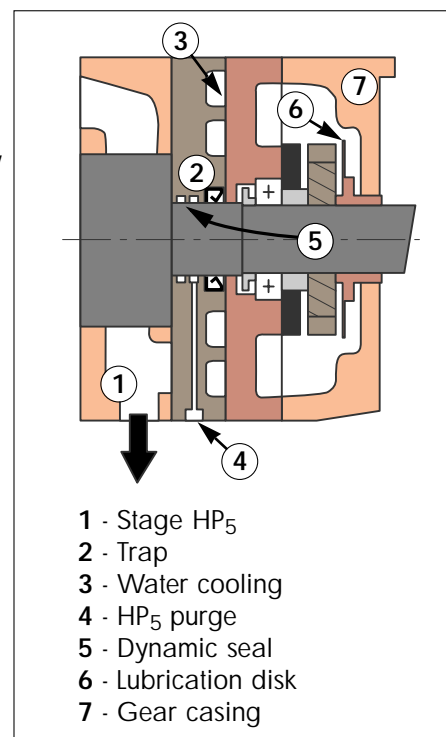

Dry pump operational principle

Tightness at motor side (shaft passage)

The vacuum tightness is ensured by the motor design with built-in jacket.

This system provides total safety regarding leaks outside the pump and requires no maintenance.

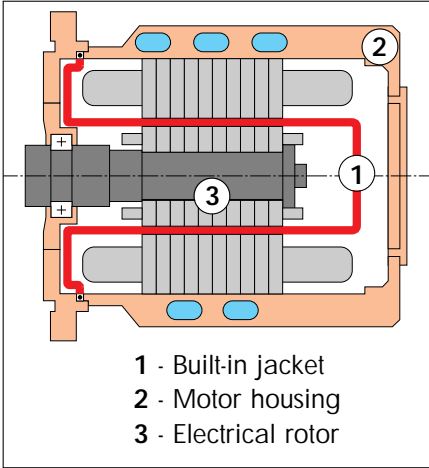

Tightness at shutdown

The pump is fitted with a antisuckback valve in the silencer, preventing the exhaust being sucked back.

The pump in a pumping installation

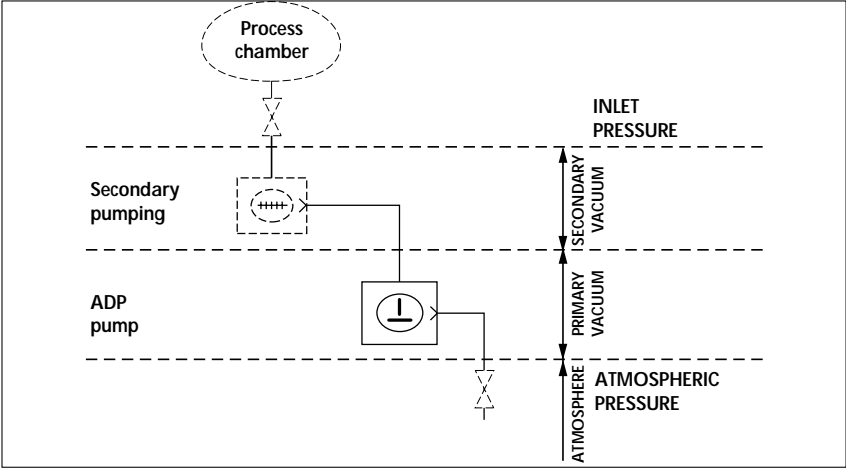

Edition 03 - May 97

The accessories

Isolation valve at pump inlet

Principle : This valve avoids a reverse flow of particles to the chamber and increases tightness when the pump is switched off. It allows also to isolate the running pump from the process.

Part Number : Several models are available in Alcatel catalog (Manual valve, electropneumatic...). Consult us.

Fitting : See section B 90

Anti-vibration pads

Principle : This device significantly reduces the vibration rate transmitted to the floor.
Vibration force to the floor by pad: < 0,5N - Available till 150Hz.

Part Number : ADP101838
ADP MD101942
ADS 151/301/501 . . .101840
ADS 151/301/501 MD 101941
ADS 801/1001102136

Fitting : See section B 30

Silencer heating kit

Principle : This device is to be installed on the silencer in order to avoid the gases condensation, particularly in processes such as Aluminum etching, Polysilicon etching, LPCVD or PECVD Nitrid.

Part Number : 110/115 V105038
220/240 V105037

Fitting : See section B 170



Technical characteristics

Characteristics	Units	ADP31	ADP 81	ADS 151	ADS 301	ADS 501	ADS 801	ADS 1001	
Nominal flow-rate (50/60 Hz)	m ³ /h	25/30	68/80	140/165	270/310	460/510	680/750	950/1000	
	l/mn	418/501	1136/1336	2338/2756	4509/5177	7682/8517	11356/12525	15835/16670	
	cfm	15/18	40/47	82/97	160/182	271/300	400/442	560/589	
Rotation speed	rpm	3000/3600							
Ultim. pressure* (50 Hz) maximale	mbar	4.10 ⁻²	4.10 ⁻²	4.10 ⁻³	3.10 ⁻³	3.10 ⁻³	2.10 ⁻³	2.10 ⁻³	
	torr	3.10 ⁻²	3.10 ⁻²	3.10 ⁻³	2.2 x 10 ⁻³	2.2 x 10 ⁻³	1.5 x 10 ⁻³	1.5 x 10 ⁻³	
Ultim. pressure* (60Hz) maximale	mbar	1.10 ⁻²	9.10 ⁻³	9.10 ⁻⁴	8.10 ⁻⁴	8.10 ⁻⁴	6.10 ⁻⁴	6.10 ⁻⁴	
	torr	7 x 10 ⁻³	6.7 x 10 ⁻³	6.7 x 10 ⁻⁴	6 x 10 ⁻⁴	6 x 10 ⁻⁴	4.5 x 10 ⁻⁴	4.5 x 10 ⁻⁴	
Max. cont. inlet pressure	mbar/torr	1000/750	50/38	40/30	30/23	20/15	10/7,5	5/4	
Max. exhaust pressure	mbar/torr	1200/900							
Supply voltage 3Ph.	volt	200/480							
Motor power (total)	kW	1,5	1,5	3	3	3	5.2	5.2	
N2 flow rate range	sccm	0 to 90000							
	NI/mn	0 to 90							
Water flow**	l/h	30 to 100					40 to 60		
Gear box fluid capac.	l	0.35	0.35	0.75	1.1	1.1	3.10	3.1	
Weight std version	kg/lb	160/353	240/529	340/748	365/805	380/844	550/1212	620/1377	
Weight mod. version	kg/lb	130/287	210/463	280/622	310/683	340/748	-	-	
Ø Inlet/Exhaust portt	DN	40/40	40/40	63/40	63/40	100/40	100/40	160/40	
Average noise level	dBA	< 70							

(Modifications reserved)

Edition 04 - May 98

* Without nitrogen supply

** According to processes (see B120)

See pumping curves at the chapter G

Technical characteristics

Dimensions Standard version

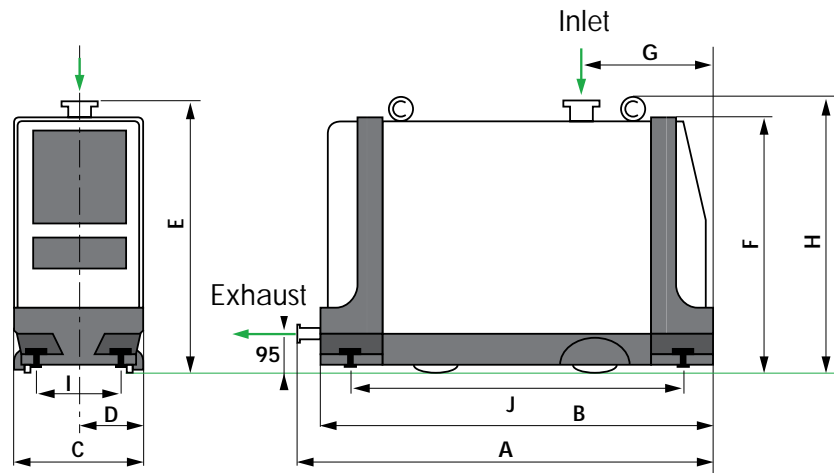

PUMP	DIMENSIONS IN MILLIMETERS									
	A	B	C	D	E	F	G	H	I	J
ADP 31	1027	975	340	170	680	650	350	711	250	884
ADP 81	1177	1125	340	170	680	650	375	711	250	1034
ADS 151	1177	1125	398	199	875	830	520	909	278	1040
ADS 301	1177	1125	398	199	875	830	520	909	278	1040
ADS 501	1177	1125	398	199	875	830	520	909	278	1040
ADS 801	1368	1331	398	199	960	913	650	995	278	1230
ADS 1001	1510	1445	398	199	1050	945	720	1050	278	1360

PUMP	DIMENSIONS IN INCHES									
	A	B	C	D	E	F	G	H	I	J
ADP 31	40.4	38.4	13.4	6.7	26.8	25.6	13.8	28.0	9.8	22.5
ADP 81	46.3	44.3	13.4	6.7	26.8	25.6	14.8	28.0	9.8	26.0
ADS 151	46.3	44.3	15.7	7.8	34.4	32.7	20.5	35.8	10.9	26.0
ADS 301	46.3	44.3	15.7	7.8	34.4	32.7	20.5	35.8	10.9	26.0
ADS 501	46.3	44.3	15.7	7.8	34.4	32.7	20.5	35.8	10.9	26.0
ADS 801	53.8	52.4	15.7	7.8	37.8	35.9	25.6	39.2	10.9	31.2
ADS 1001	59.4	56.8	15.7	7.8	41.3	37.2	28.3	41.3	10.9	34.5

Technical characteristics

Dimensions Modular version

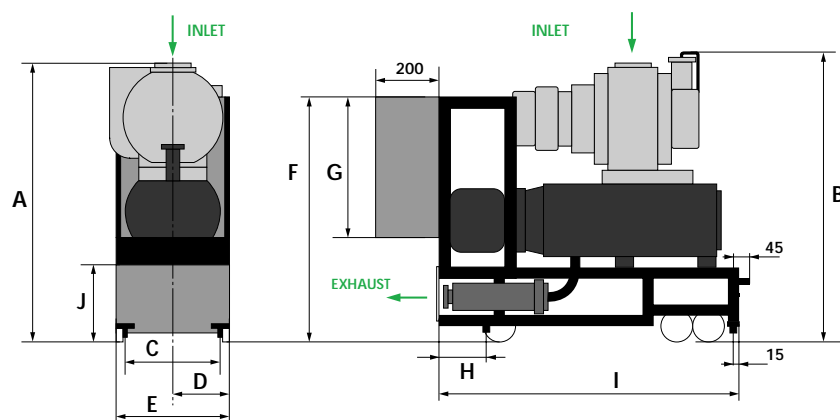

PUMP	DIMENSIONS IN MILLIMETERS									
	A	B	C	D	E	F	G	H	I	J
ADP 31MD	557	-	290	160	320	710	400	135	730	223
ADP 81MD	557	-	290	160	320	710	400	135	840	223
ADS 151MD	733	794	290	160	320	710	400	135	840	223
ADS 301MD	805	861	290	160	320	710	400	135	840	223
ADS 501MD	805	861	290	160	320	710	400	135	840	223

PUMP	DIMENSIONS IN INCHES									
	A	B	C	D	E	F	G	H	I	J
ADP 31MD	21.9	-	11.4	6.3	12.6	27.9	15.7	5.3	28.7	8.8
ADP 81MD	21.9	-	11.4	6.3	12.6	27.9	15.7	5.3	33.1	8.8
ADS 151MD	28.8	31.2	11.4	6.3	12.6	27.9	15.7	5.3	33.1	8.8
ADS 301MD	31.7	33.9	11.4	6.3	12.6	27.9	15.7	5.3	33.1	8.8
ADS 501MD	31.7	33.9	11.4	6.3	12.6	27.9	15.7	5.3	33.1	8.8

Safety instructions

- The machines must be connected to an electrical installation in compliance with the decree 88-1056 dated 14 Novembre 1988.
- Our products are designed to comply with current EEC regulations. Any modification of the product made by the user is liable to lead non-compliance with the regulations, or even to put into doubt the EMC (ElectroMagnetic Compatibility) performance and the safety of the product. ALCATEL declines any responsibility for such operations.
- Before any maintenance operation is performed by a maintenance technician who has not received safety training (EMC, electrical safety, chemical pollution, etc.), isolate the product from the various energy sources (electricity, compressed air, etc.).
- The EMC performance of the product is obtained on the condition that the installation complies with the EMC rules. In particular, in disturbed environments, it is essential to:
 - use shielded cables and connections for interfaces,
 - stabilize the power supply line with meshing from the power supply source to a distance of 3m from the product inlet.
- When the main switch is set to "0", a part of the equipment remains energized. Live circuits are exposed and accidental contact is possible (Energized electrical Work "Hot Work" in compliance with SEMI S2-93 Type 4). Before any maintenance operation, disconnect the main electrical cable.



Risk of electrical shock

Switch off the pump and disconnect the main cable. Do not operate inside if you are not trained and authorized

Safety instructions

- The EMO device is a pump EMO, not a system EMO, so it shuts only this part of the equipment. To allow the pump to start, turn the EMO button clockwise and pull it. To control the system EMO, it is necessary to wire the corresponding contacts on the "Emergency" plug (see **B 140**). Either, you can stop the pump from the system EMO by wiring the terminals on "Remote" connector (see **B 140**).
- Units containing control circuits are designed to guarantee normal safety conditions taking into account their usual operating environment (use in cabinet). In specific cases of use on a table, take care not to insert objects in the ventilation louvers when handling units.
- When switching off an item of equipment containing capacitors loaded with over 60VDC or 25 VAC, take precautions at the access to the connector pins (single-phase motors, fitting with mains filter, frequency converter, monitoring system, etc.).
- The machines are designed so as to prevent any thermal risk to the user's safety. However, specific operating conditions may generate on the pump, temperatures justifying particular attention on the part of the user (external surfaces > 70°C). Hot surfaces which can cause serious burns when touched are signalled with specific label.



Hot surface

Hot surface near the label
(pump body, silencer...)

- Alcatel has no control over the types of gases passing through this pump. These are entirely under the control of the process user and/or the hardware systems integrator. Frequently, process gases are toxic, flammable, corrosive, explosive and otherwise reactive. Since these gases can cause serious injury or death, it is very important to plumb the exhaust of the pump to the facility's hazardous gas exhaust system which incorporates appropriate filters, scrubbers, etc., to insure that the exhaust meets all air and water pollution control regulations.
- The enclosures have to be exhausted with a volumetric flow rate of 86 CFM, with a duct static pressure of 0.35" w.g. (as measured 2.0' from the duct connection to the cabinet). The size of the exhaust duct is 4", the material can be PVC, except for flammable gases for which stainless steel is strongly advised.

Unpacking / Storage



Risk of tilting: Even when compliance with EEC safety rules is guaranteed (normal range $\pm 10^\circ$), it is recommended to take precautions as regards the risk of tilting during product handling, installation and operation.

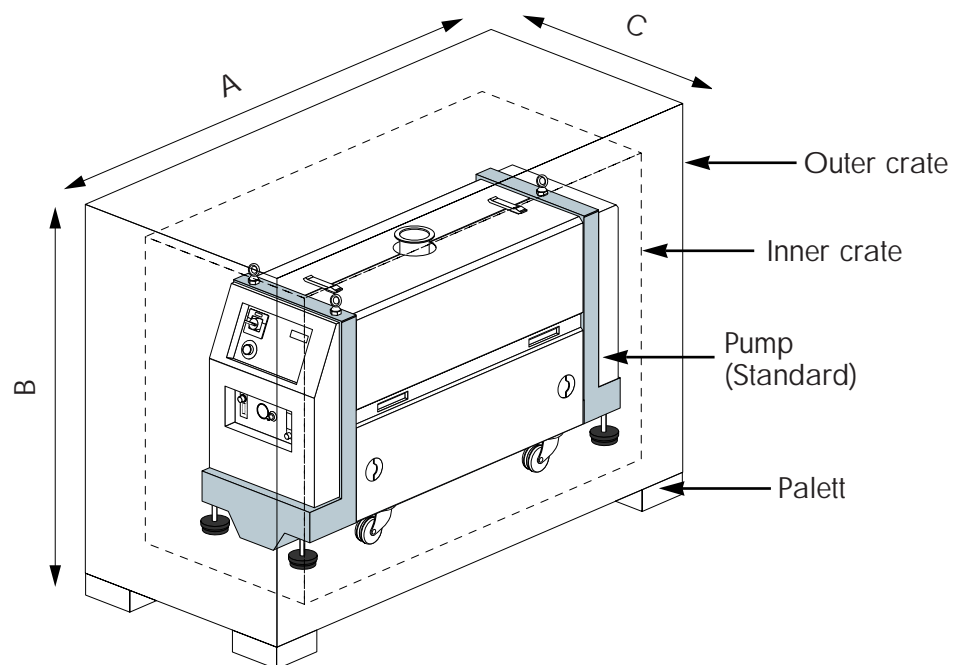

mm \pm 50 (inch \pm 2)	A	B	C
ADP 31/81 SD and MD	1350 (53)	500 (38)	980 (19.7)
ADS 151/301/601 St and MD	1350 (53)	1150 (45)	520 (20.1)
ADS 801/1001	1900 (74.6)	1520 (58)	810 (32)



If the equipment has been damaged, take necessary steps with the carrier and inform Alcatel, if necessary. In all cases, Alcatel recommends that the packaging be saved, in the event that the equipment must be transported or put into prolonged storage.

Unpacking

- Remove the top of the outer crate.
- Remove the long side of the outer crate. This side is attached with screws; all the other sides are held with nails.

Unpacking / Storage



For all equipment handling, use the devices provided for this purpose (lifting rings, handle, etc.) .

Remove the pump from the crate

It is highly recommended to use a hoist. Lift the pump by its three hoisting rings. Apply just enough upward tension to take the weight off the base of the pump.

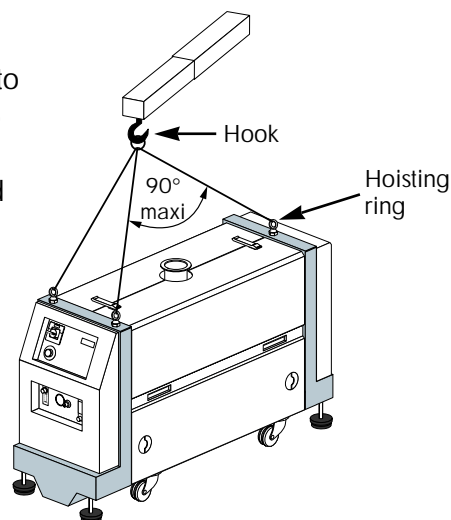

Pump Type	Weight in lbs/(kg)
ADP 31	353 (160)
ADP 81	529 (240)
ADS 151	748 (340)
ADS 301	805 (365)
ADS 501	844 (380)
ADS 801	1212 (550)
ADS 1001	1377 (620)

Prepare the pump

Screw the leveling pads of the frame and lower the pump on the wheels.
Remove any additional packages from the crate and set aside. These packages will contain cables, accessories, and so forth.

To prevent humidity from entering the pump during transport, the pump is pressurized with dry nitrogen before shipment. The inlet and exhaust are sealed with blank-off flanges which should not be removed until the pump is ready to be used.

Equipment storage



If the pump is going to be put into storage, the inlet and exhaust, seals should be left in place.

Our equipment can be stored without particular storage precautions (pump pressurized in nitrogen and sealed) at an ambient temperature between -20°C and + 70°C.

Positioning the pump in the pumping installation



- Pump performance will depend on the kinds of accessories used and the quality of the mechanical connections such as pump fittings.

- As these pumps are typically used in a corrosive atmosphere, their reliability will depend on proper installation and maintenance. When assembling the vacuum circuit, make sure to provide necessary maintenance accessories such as shut-off valves on the inlet, exhaust, and purge lines.

- For safety reasons, use accessories on the inlet and exhaust lines whose materials and sealing properties are compatible with the gases being used.

Positioning the pump

Determine where the pump will be placed. Refer to the technical specifications section for dimensions, if needed (section A).

Use a hoist to handle the pump, lifting it by the three hoisting rings.



The pump must be operated in the horizontal position, with the pumping axis vertical and the inlet opening upwards.

Each pump is equipped with a locking screw jack on each corner. Lock the pump by adjusting these jacks so that all four feet are resting solidly on the floor.

See section B30 for installing Anti-vibration Pads.

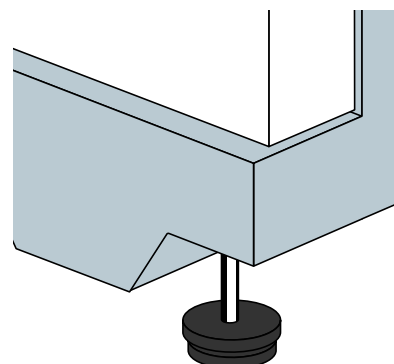

Positioning the pump in the pumping installation

- Remove pump covers**
- Unfasten the toggle joints located on the top of the cover (1).
 - Unfasten the lateral fastening and raise the cover by the handles (2).

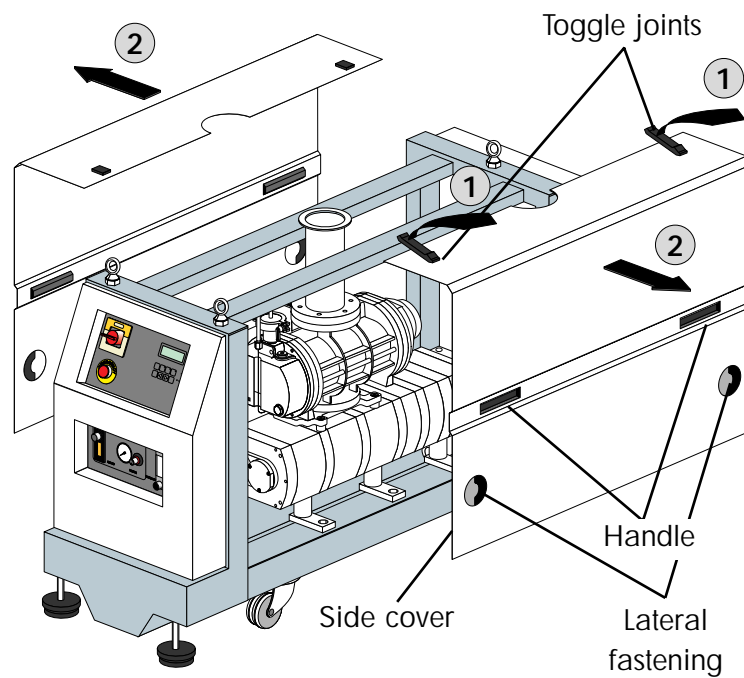

Positioning the pump in the pumping installation

 Risk of tilting: Even when compliance with the EEC safety rules is guaranteed (normal range $\pm 10^\circ$), it is recommended to take precautions as regards of the risk of tilting during product handling, installation and operation.

Removing the shipping braces

- The shipping braces hold the pump to the frame during shipment. They are painted yellow, for easy identification.

 Release the pump(s) from the frame before use. Keep the flanging components in order to dispatch the equipment, if required.

- Remove these bars and the threaded rods which hold them.

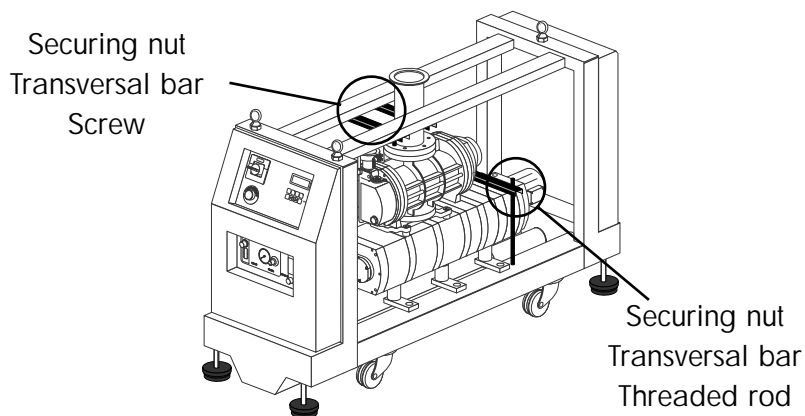

Modular version

The shipping braces are also used as hoisting device.



 Failure to remove the shipping braces could later cause the pump to seize as a result of a strain exerted by the braces.

Installing anti-vibration pads (Accessories)

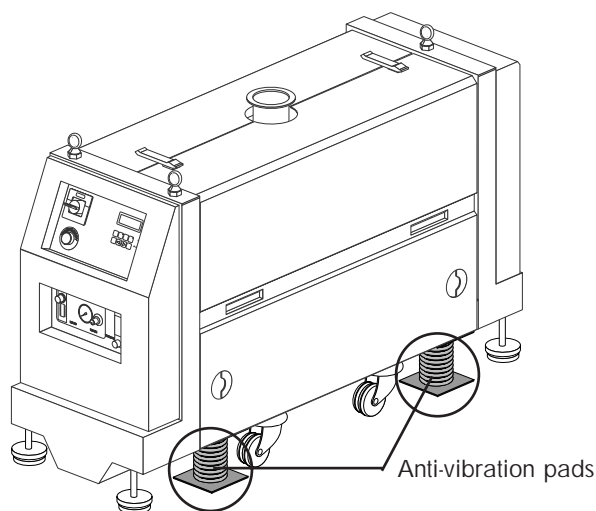

ADP/ADS Standard version

The ADP/ADS pumps can be equipped with anti-vibration pads which are mounted beneath the pump, near the locking feet.

- Remove the covers as described in section **B 20**.
- Raise the pump using the 4 screws jacks.
- Screw into the previous holes the 4 anti-vibration pads.
- Screw the screw jacks so that the machine rests on the pads.

**Force transmitted to the ground by each support: <math>< 0.5\text{ N}</math>
for frequencies $\leq 150\text{ Hz}$.**

In order to limit the transmission of vibrations along the pipes, it is recommended to use «flexible» connection accessories at the inlet and exhaust side (expanding type).

ADP/ADS Modular version

On the modular version :

- Screw the delivered angle into the frame holes after removing the shipping braces.
- Install the anti-vibration pads (as shown opposite).

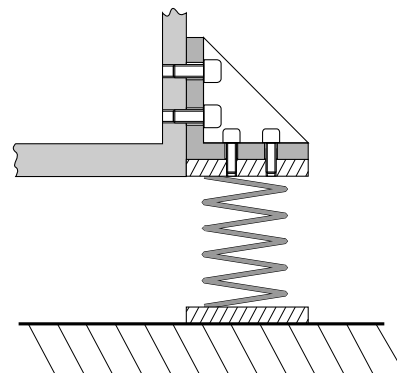

Modular version - Layout

Main modules layout (electrical box, flowmeter panel, water and gas utilities, customer interface) fit the customer choice among factory set configurations. Other layouts are possible, see the following page.

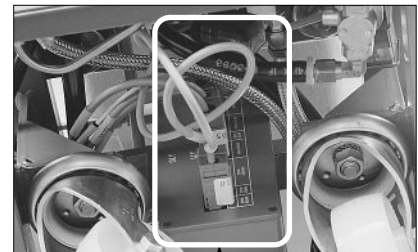

Sensor box

To modify the modules layout, some rules have to be followed :

- Pump(s) cannot change its(their) orientation with respect to the frame.
- The sensor box, located under the pump, has to be set facing the silencer.

Stabilizer kit for modular ADS

For safety reasons, the modular ADS are now equipped with a stabilizer to avoid any risk of toppling over. It consists of two supports, one either side of the frame, equipped with rollers at the bottom. They slide into a housing and are bolted into place during transport. The housing is bolted to one end of the frame.

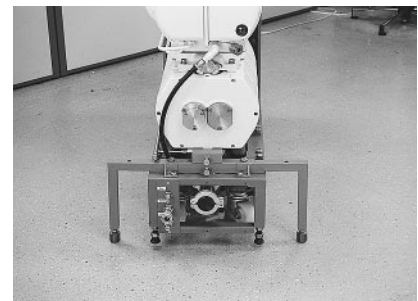

When pump is installed, the supports are stored, legs up, and fixed by means of two bolts. This kit is a part of modular pumps marked with a serial number upper than 973187. It can be fitted to retrofit on older pumps by ordering P/N 104527.

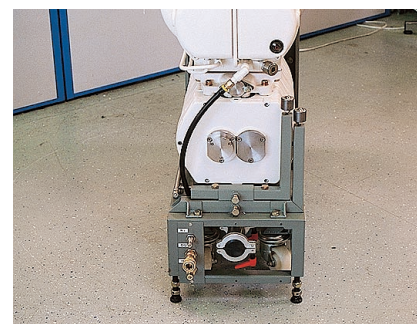

Positioning in pumping installation

See page B 20.

Modular version - Layout

5 basics modules for 8 pumps configurations



Pump block with frame



Control box with integrated monitor

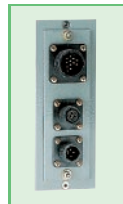

OEM interface



Utilities panel

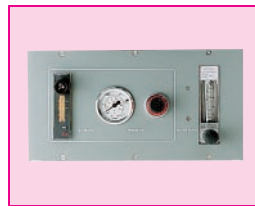

Flowmeter panel

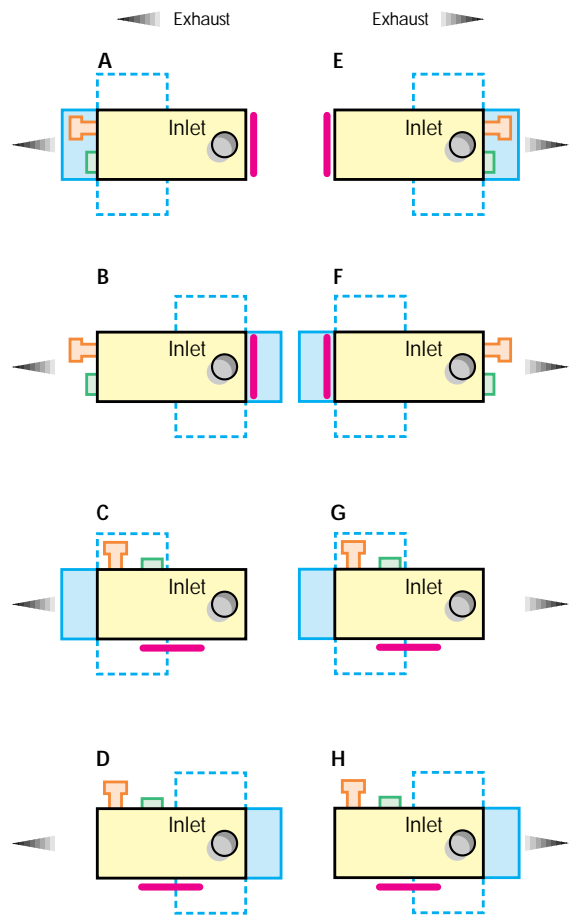

Some location examples

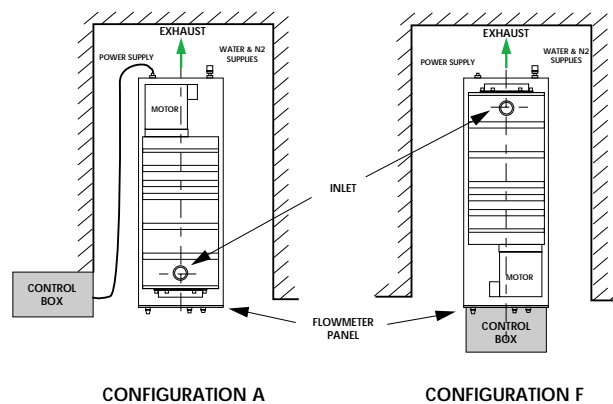

Filling the machine oil housings

 **Caution !** The pumps are delivered without an oil charge: the oil is found in separate containers. Similarly, it is recommended to drain the pump before redispaching the equipment.

 For machines wich use lubricants, it is recommended to request the manufacturer for the safety data sheets concerning the product used.

The pump is tested using synthetic fluid Alcatel 113.

When pumping corrosive gases, we recommend synthetic fluid Alcatel 113.

 **Mineral and synthetic oils cannot be used together.** Contact Alcatel or your service agent before making any changes.

Oil quantities

OIL FILLING :				
HOUSINGS :	ADP	REAR ROOTS HOUSING	FRONT ROOTS HOUSING	TOTAL CAPACITY
ADP 31/81	0.35 L			0.35 L
ADS 151	"	0.25 L	0.15 L	0.75 L
ADS 301	"	0.45 L	0.25 L	1.05 L
ADS 501	"	0.45 L	0.25 L	1.05 L
ADS 801	"	1.95 L	0.80 L	3.10 L
ADS 1001	"	1.95 L	0.80 L	3.10 L

Filling procedure

- Proceed to oil filling when the pump is stopped.
- Remove the fill cap.
- Fill the pump with oil.

Do not exceed the indicated quantities.

The oil level should be in the middle of the sight glass.
For this to be accurate, wait a few minutes for the oil to settle over all internal surfaces.

Replace the fill cap.
(See location page 2)

Filling the machine oil housings

Location

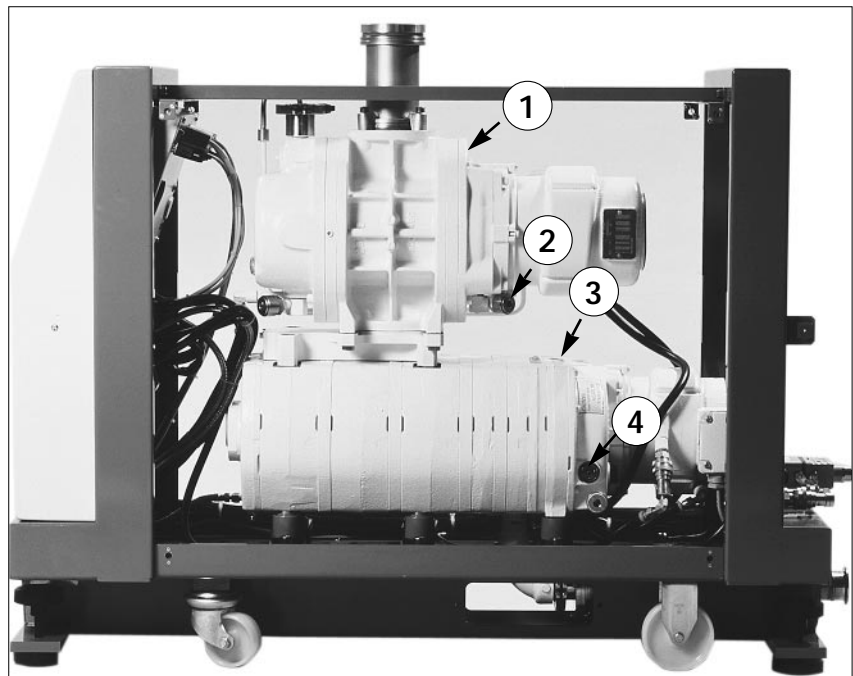

- 1 - Filling front Roots housing
- 2 - Front Roots housing level sight glass
- 3 - ADP filling
- 4 - ADP housing oil level sight glass

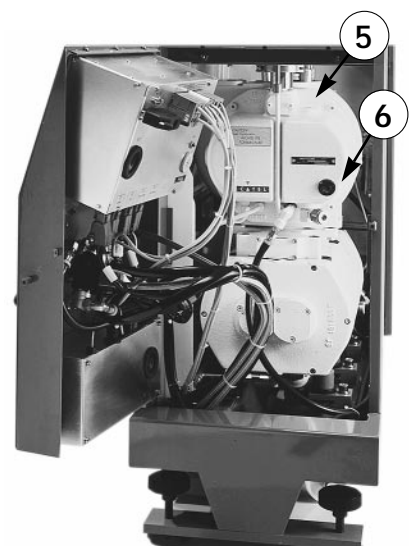

Connection to the cooling circuit

Water characteristics

In order to limit corrosion and fouling of the motor cooling coils, it is recommended to use cooling water with the following characteristics :

- Treated fresh water or non-aggressive industrial water
- pH between 7.5 and 11
- Hardness < 7 milli-equivalent/dm³
- Resistivity > 1500 Ω.cm
- Solid pollution < 100 mg/dm³
- Temp. from 10° to 25°C
- Pressure range between 3 and 7 bars absolutes
- Pressure Δ inlet/outlet 3 bars minimum

If the above mentioned characteristics are not respected, install a filter to the cooling connection.

Standard version connections

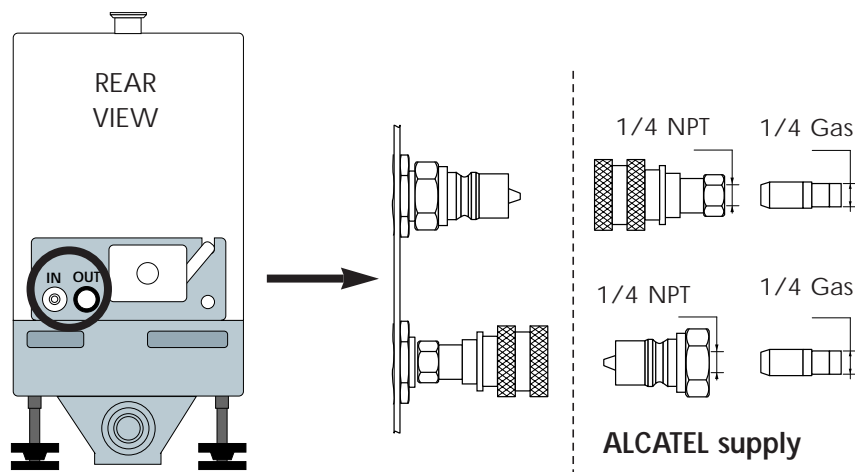

Connection to the cooling circuit

Modular version connections

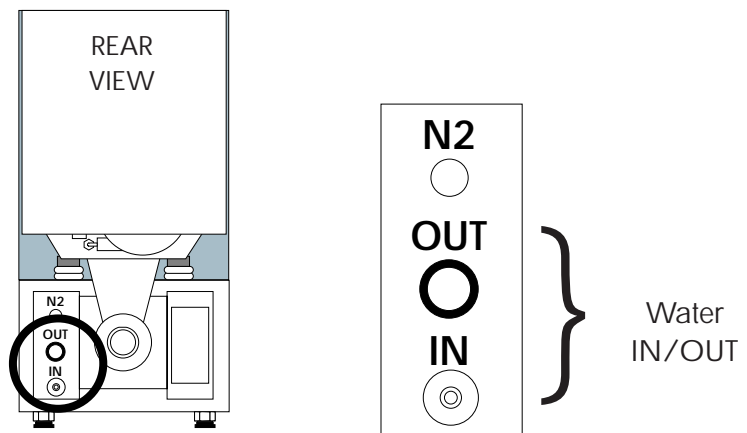

Waterflowrate adjustment

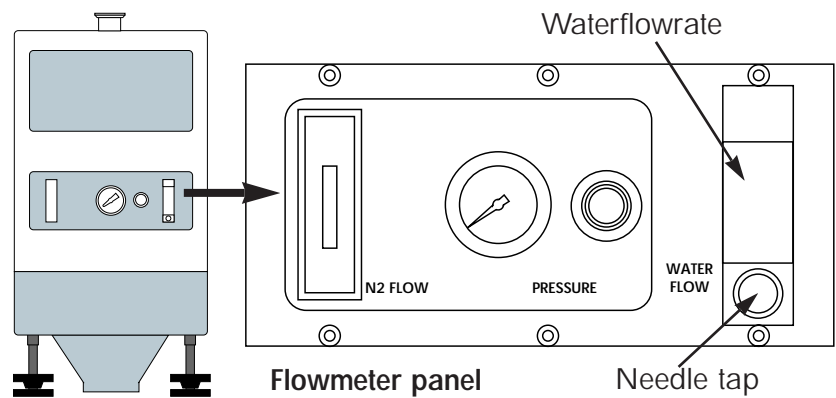

The water flow will be adjusted according to the processes with the needle tap (see section B120).

Inert gas purge connection (N2 plug)

Nitrogen characteristics

A filtered dry nitrogen supply is required.
It should have the following characteristics :

- Dew point < 22° C
- Dust < 1µ.m
- Oil < 0,1 PPM
- Pressure between 3 and 7 bar absolute.
- Flowrate per pump: 100 l/min.

Standard version connections

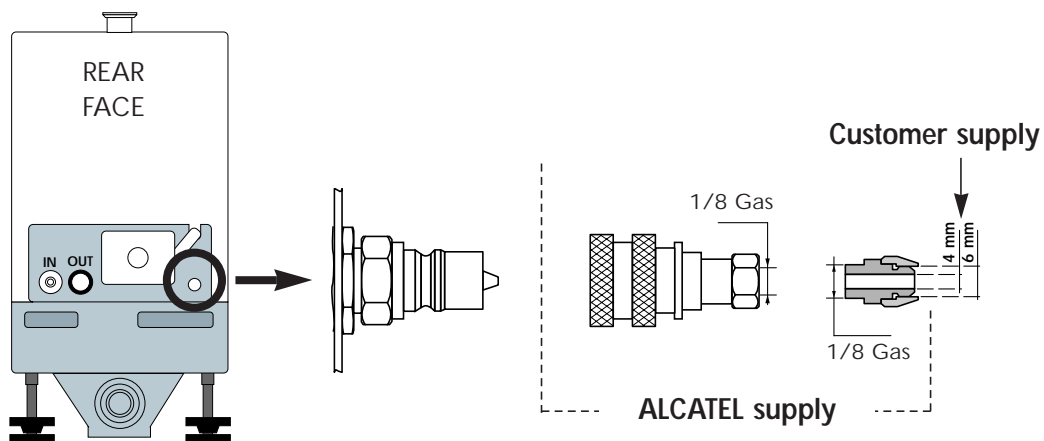

Modular version connections

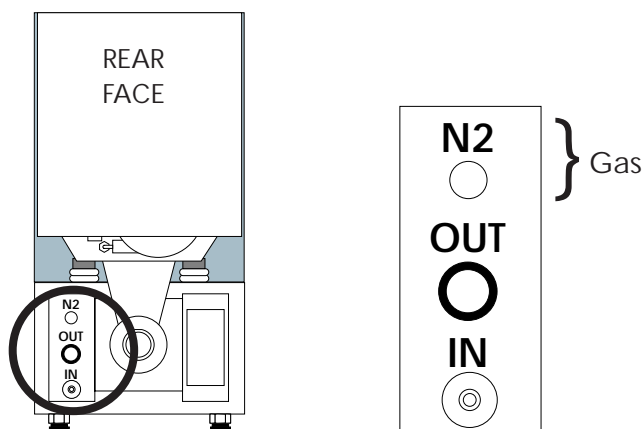

Inert gas purge connection (N2 plug)

N2 flowrate adjustment

The N2 flowrate will be adjusted with the pressure regulator according to the process (*see section B 120*).

The flowmeter is used to display **the overall purge flow rate**.

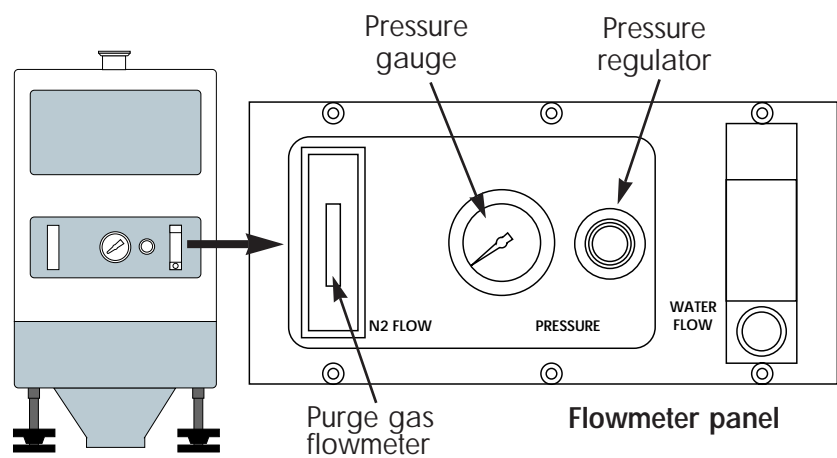

Nitrogen purge flow sensor

Function This sensor is used to warn the user when the N₂ flow comes under a preset value during harsch processes using dangerous gases (SiH₄ for example).

Operation The gas flow rate through the detector carries along a float which acts on the contact of the electrical box. This contact closes when the flow rate value is higher than the flow rate set on the sensor. Otherwise the contact opens and set off an alarm "**PURGE FLOW**".

Location To get access to the flowmeter, remove the side cover from the pump.

Adjustment

- First set the parameter "**N₂ FLOWRATE OPTION**" to be valid in the "**DEFINITION**" menu of the M3 monitoring system.
- The setting of the sensor is done by sliding the moving part (contact) along the controller body. For this, loosen the screws fixing this moving part on the body
- Adjust the electrical box in the upper position.
- Set the minimum Nitrogen flowrate to be detected with the corresponding purge pressure (**See B 120**).
- Adjust the position of the moving part from top to bottom until the **PURGE FLOW** is displayed on the screen of M3 monitoring. Fix it with the screws.
- Check the good operation by increasing the purge pressure to a level higher than the one to be detected, then reduce this pressure until the purge alert is triggered. Note if this triggering pressure corresponds to the minimum required one.

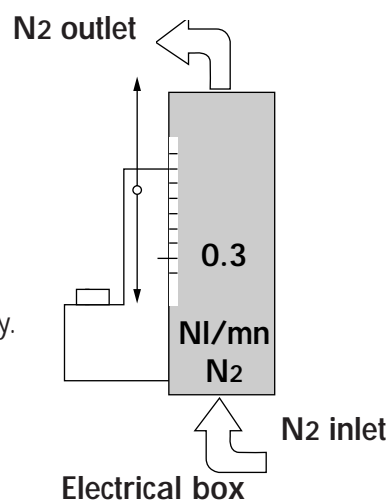

Connection to the pumping circuit

 In order to prevent moisture from entering the pump before its installation, it is pressurized beforehand with nitrogen and sealed with blank-off flanges.

 The vacuum pump is also a compressor: incorrect use may be dangerous. Study the user manual before commissioning the pump

At the exhaust pump

First of all, remove the plug at the exhaust.

Preliminary precautions

 Provide maintenance accessories, for vacuum circuit mounting (inlet and exhaust isolation valves, purges, ...) It is recommended to connect the pump exhaust to a flue gas evacuation pipe.

For safety reasons, use at pump inlet as well as exhaust, accessories with materials and tightness compatible with pumped gases.

Anti-noise seal

For free exhaust tests (inert gas pumping), an anti-noise seal supplied with the pump can be fitted on to the silencer exhaust in order to reduce the exhaust noise level.

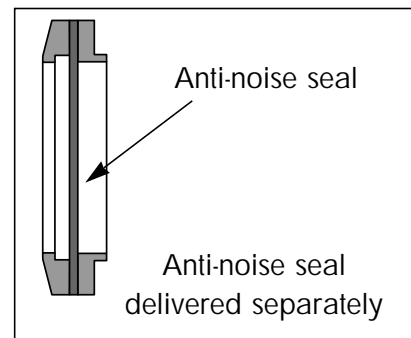

 When pumping on aggressive gases, the exhaust must be connected to a stack or an evacuation duct.

In this case, do not fit the anti-noise seal.

Make sure that the pressure at the exhaust does not exceed 1200 mbar.

Connection to the pumping circuit

Exhaust connection DN40 ISO KF Pneurop.
Several fitting accessories are available in Alcatel catalog.

At inlet pump



Make sure that the parts or containments connected to the inlet of our pumps withstand a negative pressure of 1 bar with reference to the atmospheric pressure.

In order to prevent foreign bodies from entering the pump, leave the blank-off flange in place at the pump inlet and remove it at the time of use.

(see section B 130).

Inlet isolation valve (accessory)

This accessory avoids a reverse flow of particles to the chamber when the pump is stopped.

Connect the valve directly on the pump inlet flange using connecting accessories.

Connect the valve to the chamber.

Connect the electrical cable to the **"inlet valve / exhaust valve"** connector at the rear of the M3 monitoring system.

Pump Power supply



Study the preliminary precautions (See B 00)

All the electrical connections required for operation have been done in the factory.

However, the user must make the electrical connection of the main power supply, connect the remote monitoring system options.

Customer electrical installation protection

MAIN CIRCUIT BREAKER RATING : (Minimum value) :				
	ADP 31/81	ADP 81V	ADS 151/301/501	ADS 801/1001
LV	15A	20A	20A	25A
HV	10A	15A	15A	20A

For any change of power supply voltage in relation to the initial configuration, contact Alcatel Customer Service.

Cutt off rating of main pump switch :

- 200 to 415 V : 50 kA
- 460 V : 20 kA
- 480 V : 10 kA

The main switch on the monitoring front panel can be locked with a catch hook attached to the emergency stop button. Even if the main switch is locked in the "1" position, the disconnecting function remains operational.



Pump Power supply

Standard version

The pump is supplied with a female connector which is connected to the electrical connector at the lower part of the frame. Connect the mains to the power supply connector using a 4 x 4 mm².

Then connect the connector on the pump frame.

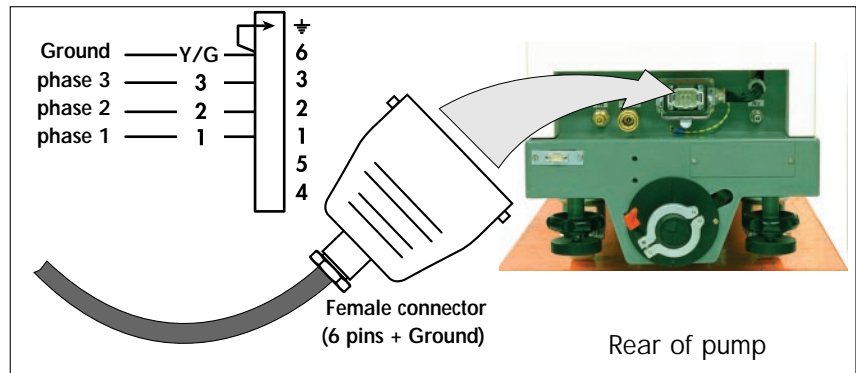

Check the rotational direction of the pump at the first pump start-up (See section B 130).

Modular version

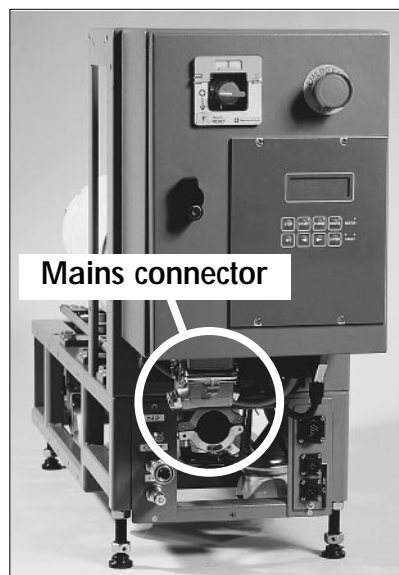

Mains connector is located on the electrical box lower face.

The connection has to be carried out as defined previously in page 1.

Pump Power supply

Connectors of remote set electrical box

Remote set electrical box is connected by means of a 5 meters extension cable.

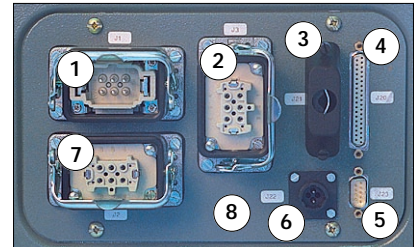

- | | |
|-------------------|------------------------------|
| ① Mains connector | ② Roots supply (ADS) |
| ③ Remote control | ④ Sensors information (n° 1) |
| ⑤ RS 232 / RS 485 | ⑥ Interface connector |
| ⑦ ADP supply | ⑧ Sensors information (n° 2) |



Check the rotational direction of the pump at the first start-up (See B 130).

Water flowrate and gas purge according to main semiconductor processes

Standard pump setting (no TC)

	Processes	Pump version	Nitrogen	Water	
PROCESSES 1	<ul style="list-style-type: none"> • Load lock * <i>If possible chlorine degassing</i> • Sputtering • Dielectric etch • Stripping with plasma O₂ - trap can be useful (proposed by some manufacturers) • Resist and polyamid etch - trap can be useful (proposed by some manufacturers) 	non CVD	No	100l/h	P 1 Maintenance
		non CVD	* 20l/mn (0.2 bar)	100l/h	
		non CVD	No	60l/h	
		non CVD	25l/mn (0.3 bar)	60l/h	
PROCESSES 2	<ul style="list-style-type: none"> • Metal etch - heated piping and exhaust lines advised • Poly etch • Ion implant (source) • Tungsten LPCVD • Titanium and Titanium nitride PECVD • Polysilicon LPCVD and PECVD • Silicon oxide PECVD and LPCVD using Silane 	non CVD	35l/mn (0.6 bar)	40l/h	P 2 Maintenance
		non CVD	35l/mn (0.6 bar)	60l/h	
		non CVD	35l/mn (0.6 bar)	40l/h	
		non CVD	45l/mn (1 bar)	100l/h	
		non CVD	35l/mn (0.6 bar)	60l/h	
		CVD	50l/mn (1 bar)	60l/h	
		CVD	50l/mn (1 bar)	60l/h	
PROCESSES 3	<ul style="list-style-type: none"> • Silicon oxide and doped oxide (BPSG) PECVD using TEOS • Silicon oxide and doped oxide (BPSG) LPCVD using TEOS • Silicon nitride PECVD • Silicon nitride LPCVD - cold trap at the outlet of the furnace can be useful - no heating of the line between the cold trap and the pump. * Should the layer be thick (>1500Å), please contact Alcatel Worldwide Technical Support for dry pumps. 	CVD	50l/mn (1 bar)	60l/h	P 3 Maintenance
		CVD	70l/mn (1.5 bar)	40l/h	
		CVD	70l/mn (1.5 bar)	40l/h	
		CVD	70l/mn (1.5 bar)	40l/h	
		CVD	90l/mn (2 bar)	40l/h	

Water flowrate and gas purge according to main semiconductor processes

"TC" Pump setting

	Processes	Pump version	Nitrogen	Pump temperature
PROCESSES 2	• Metal etch - heated piping and exhaust lines advised	non CVD	35l/mn (0.6 bar)	90°C
	• Poly etch	non CVD	35l/mn (0.6 bar)	80°C
	• Polysilicon LPCVD and PECVD	CVD	45l/mn (0.8 bar)	80°C
	• Silicon oxide PECVD and LPCVD using Silane	CVD	50l/mn (1 bar)	80°C
	• Si mono. Epitaxy	CVD	50l/mn (1 bar)	80°C
PROCESSES 3	• Silicon oxide and doped oxide (BPSG) PECVD using TEOS	CVD	50l/mn (1 bar)	90°C
	• Silicon oxide and doped oxide (BPSG) LPCVD using TEOS	CVD	70l/mn (1.5 bar)	90°C
	• Silicon nitride PECVD	CVD	70l/mn (1.5 bar)	90°C
	• Silicon nitride LPCVD - cold trap at the outlet of the furnace can be useful - no heating of the line between the cold trap and the pump. * Should the layer be thick (>1500Å), please contact Alcatel Worldwide Technical Support for dry pumps.	CVD	90l/mn (2 bar)	100°C

Checking the rotational direction



Study the preliminary precautions (See B 00)



Before using the pump, check that the connections defined in the start-up chapter have been made. Also, make sure that all the oil levels are visible at the center of the indicator.

- Remove the guards blocking the intake and exhaust (and, if applicable, purge) holes; these components prevents foreign bodies from entering the pump during transport and storage. It is dangerous to leave them on a pump in operation.

Check the rotational direction of the pump at the first pump start-up

- Remove the blank-off flange on the inlet port.
- Fit a pressure gauge at the pump inlet.
- Set the main switch on I.



When inspecting the direction of rotation of the Roots pump at installation, provide protection against the risk of compression related to the rotating machine on the inlet. **Caution ! A non-powered Roots can be driven by another pump in rotation (risk of compression) .**

- Start up the pump by pressing "START" and stop it after a few seconds :
 - if the pressure indicated is less than $5 \cdot 10^{-1}$ mbar, the rotational direction is correct.
 - if the pressure increases, **invert two phases at the mains input female connector.**
- Connect the pumping circuit.
(Note : In the case of an ADS 801 or ADS 1001, do not start the Roots.)

Note : We can also check that the pump is forcing back at the exhaust after that the blank-off flanges have been removed from inlet and exhaust. If not, invert two phases.

Remote control plug connection (M3 monitoring)



Study the preliminary precautions (See B 00)



When units containing control circuits are equipped with dry contact outputs, it is the responsibility of the customer to use these outputs in compliance with safety standards.

Remote control function allows to :

- Remote control of pumping functions "START/STOP/Emergency stop/PURGE".
- Copy out with dry contacts (250V - 1A - 100VA) the monitoring parameters. These contacts can be used to control automatisms.

Monitoring system M3 Remote control «REMOTE»

Wiring of the cover plug to put if the remote control is not used (REMOTE plug).

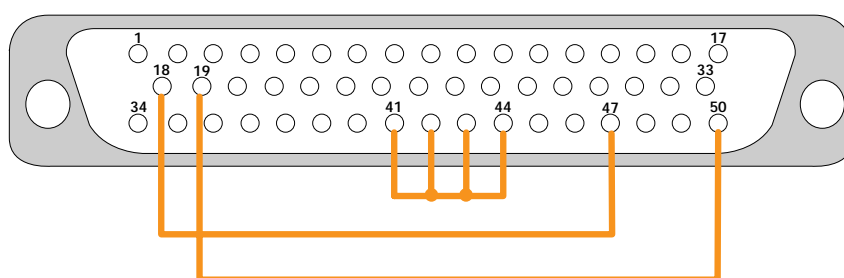

Remote control plug connection (M3 monitoring)

Control (Inputs) Monitoring system M3

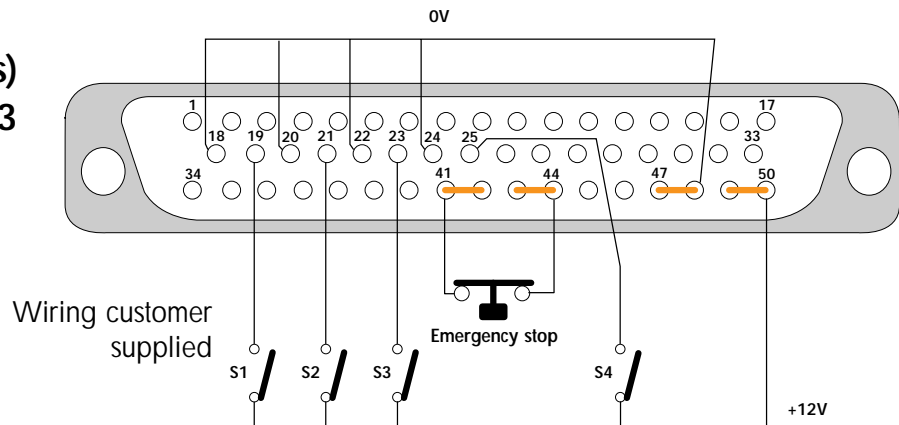

NOTE : The contact is considered to be closed if the DC voltage between 5 and 30 V is applied.
These contacts can be supplied by terminals 47 (0V) and 49 (+12V).

- S1 : OPEN Remote control valid / Keyboard locked
- S1 : CLOSE Keyboard valid / Remote control locked
- S2 : On / ADP switching off
- S3 : On / ROOTS switching off **if the selection "Roots control" has been validated**
- S4 : Purge Switching on / off **if the selection "Purge control" has been validated** in the help menu with keyboard.

Monitoring system before V2.02 version

Note: If the remote control receives an order from the RS232, keyboard and remote control are locked. Only **LOC** order transmitted by the RS232 allows to enable keyboard or remote control. **(Contact Alcatel)**

Remote control plug connection (M3 monitoring)

Available outputs of Monitoring system M3

Dry contacts : 250 V - 1 A - 100 VA

	Contact
These contacts open in the presence of a fault.	
1 - ADP working	14 - 15
2 - ROOTS working	16 - 17
3 - Purge flow rate and ADP working	8 - 9
4 - Exhaust pressure fault : P>1450mbar	39 - 40
5 - Purge fault	37 - 38
6 - Temperature fault : T° > 50° C	35 - 36
4 - Fault (One of the parameters at alert threshold)	2 - 3
5 - Fault (Alarm threshold reached, unit stop)	4 - 5
6 - Pump fail (Alarm signal detected and ADP working)	1 - 34
These contacts close in the presence of a defect :	
1 - Fault (One of the parameters at alert threshold)	12 - 13
2 - Fault (Alarm threshold reached, unit stop)	11 - 10

State of «Emergency» Monitoring system M3

The front panel emergency stop button copy out contact is available **between 1 and 2 contacts** of "emergency" plug at the rear of the monitoring system.

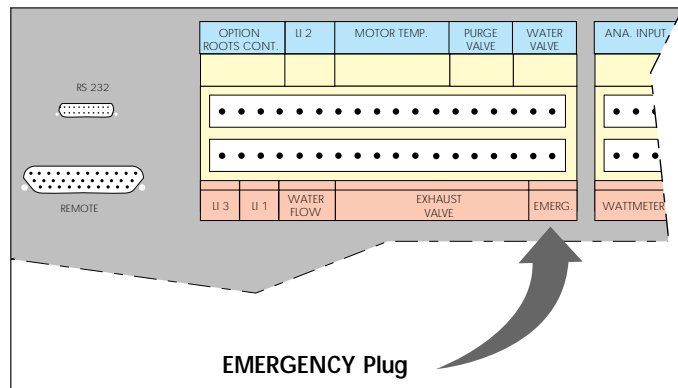

Remote control plug connection (M1 monitoring)



Study the preliminary precautions (See B 00)



When units containing control circuits are equipped with dry contact outputs, it is the responsibility of the customer to use these outputs in compliance with safety standards.

Remote control function allows to :

- Remote control of pumping functions "START/STOP/Emergency stop/PURGE".
- Copy out with dry contacts (250V - 1A - 100VA) the monitoring parameters. These contacts can be used to control automatisms.

M1 Monitoring system
M1 Remote monitoring
Remote control
«REMOTE»

If the remote control is not used, put (REMOTE plug) the cover plug wired like :

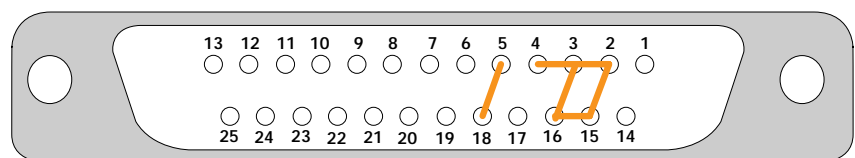

Controls (Input)
Monitoring system M1

Without inhibition of remote control buttons :

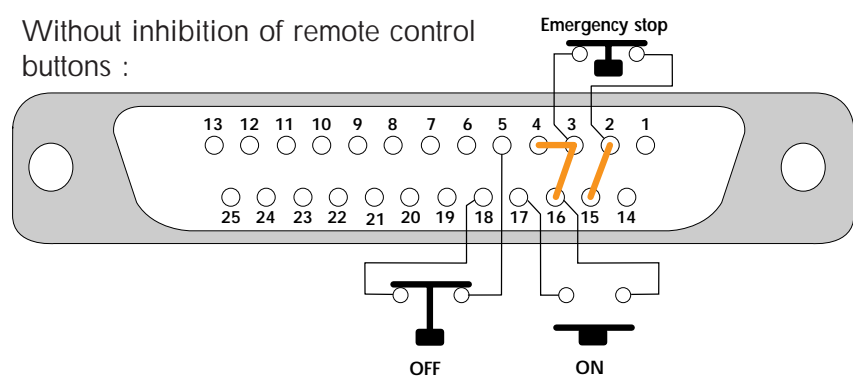

With inhibition of remote control buttons:
With switch :

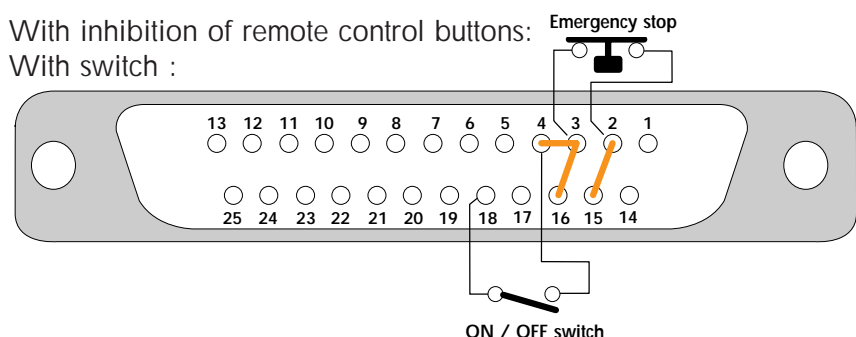

The remote control STOP button will stop the ADP, but it will restart as the push button is released.

Remote control plug connection (M1 monitoring)

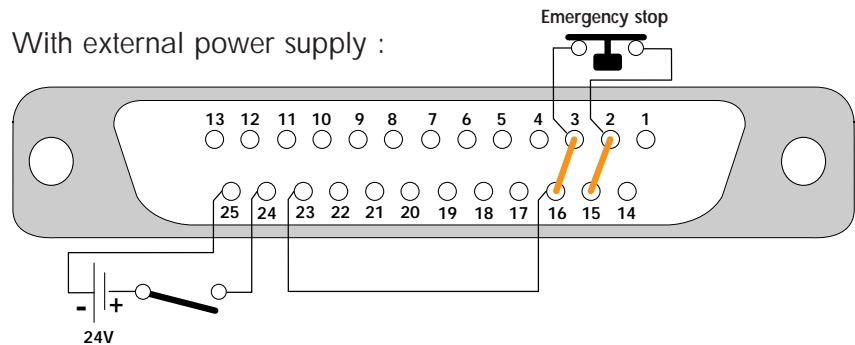

Available outputs of Monitoring system M1

Dry contacts : 250 V - 1 A - 100 VA

These contacts open in the presence of a fault.
Two contacts available for each fault type.

Available outputs :	Contact 1	Contact 2
1 - Major faults : RT1 switched off	12 - 13	8 - 21
2 - Pump working : KM1 switched off	9 - 22	6 - 19
3 - Temperature faults : T° > 50° C	10 - 11	7 - 20

State of «Emergency» Monitoring system M1

The front panel emergency stop button copy out contact is available **between 7 and 8 contacts** of "emergency" plug at the rear of the monitoring system.

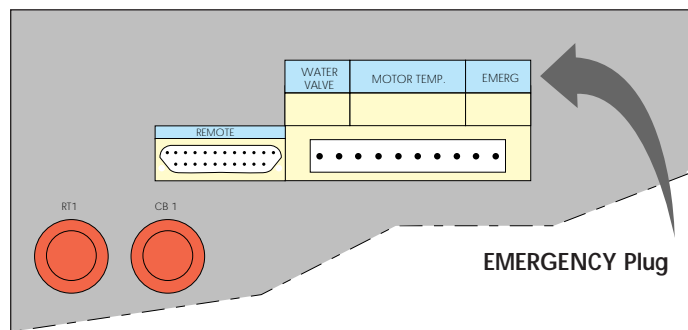

Remote control plug connection (M1 monitoring)

M1 Monitoring system on modular ADP Remote control «REMOTE»

If the remote control is not used, put (REMOTE plug) the cover plug wired like :

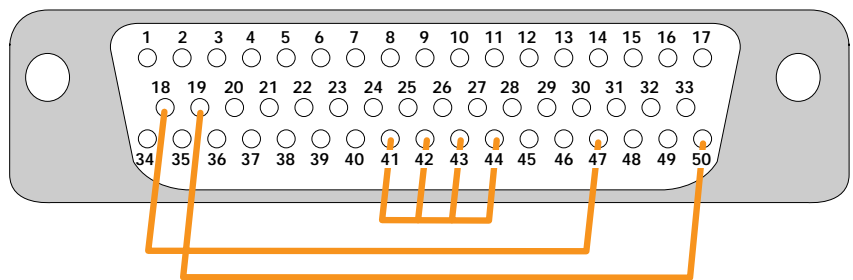

Control (Inputs) Monitoring system M1

Without inhibition of
remote control buttons :

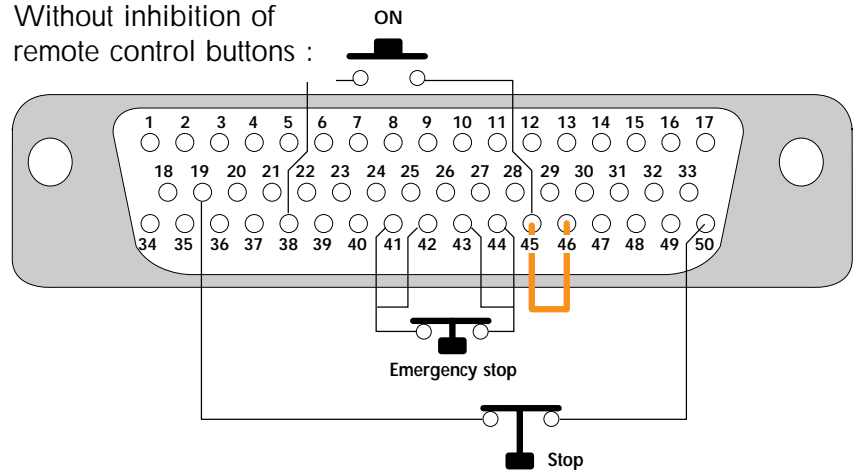

With inhibition of remote control buttons:
With switch :

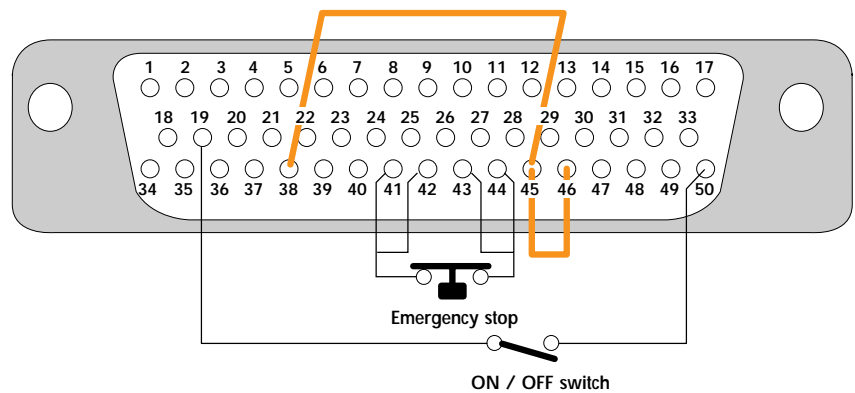

The remote control STOP button will stop the ADP, but it will restart as the push button is released.

Remote control plug connection (M1 monitoring)

With external power supply :

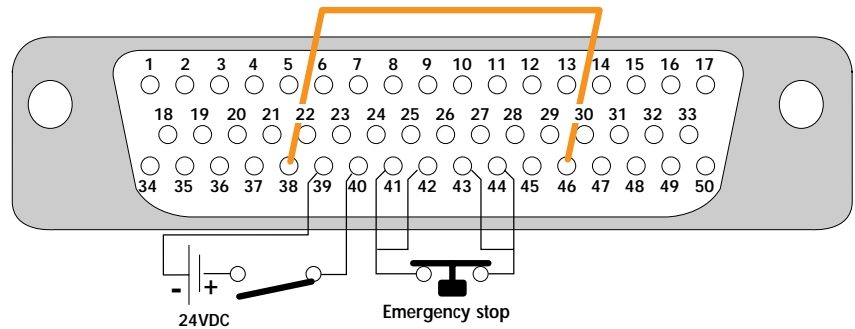

Available outputs of Monitoring system M1

Dry contacts : 250 V - 1 A - 100 VA

These contacts open in the presence of a fault.
Two contacts available for each fault type.

Available outputs :	Contact 1	Contact 2
1 - Major faults : RT1 switched off	12 - 13	8 - 21
2 - Pump working : KM1 switched off	8 - 10	14 - 15
3 - Temperature faults : T° > 50° C	5 - 7	35 - 36

State of «Emergency» Monitoring system M1

The front panel emergency stop button copy out contact is available **between 7 and 8 contacts** of "emergency" plug at the rear of the monitoring system.

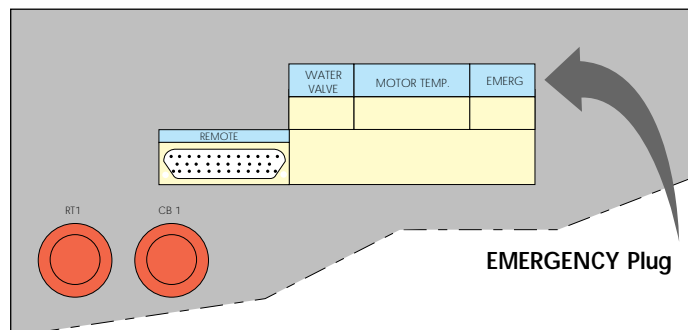

RS 232 or RS 485 link wiring

At the first power-on, the user will find the initial configuration set at factory.

The settings can be modified through the M3 corresponding menu.

The initial configuration of the serial link is as follows:

- Type : **RS 232**
- Transmission SPEED : **9600 bauds**
- Data Length : **8 bits**
- Parity : **NONE**
- Stop bit : **1**

Connector wiring RS232/485

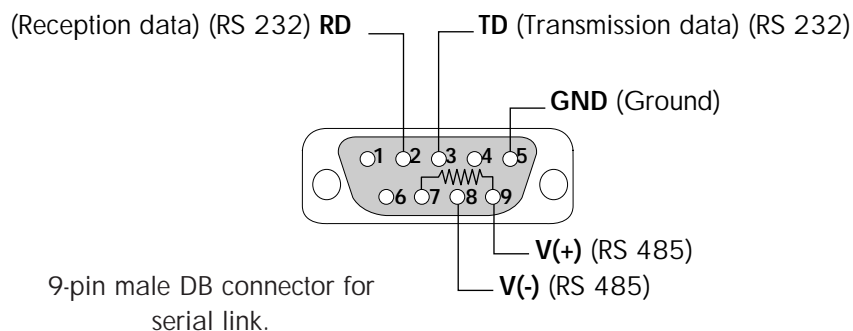

RS 232 or RS 485 link wiring

Examples of possible connection

Link RS232
with a single
monitoring system M3



Multiple serial link
RS232

Several M3 monitoring systems may be connected on a single link.

The multiple link is obtained by creating a loop:

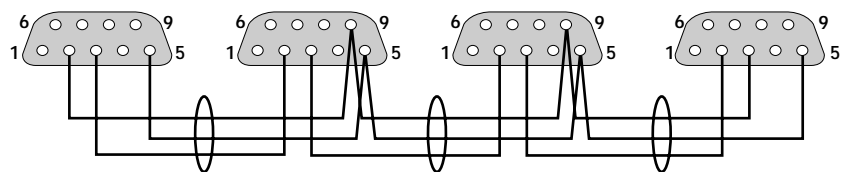

Serial link RS485

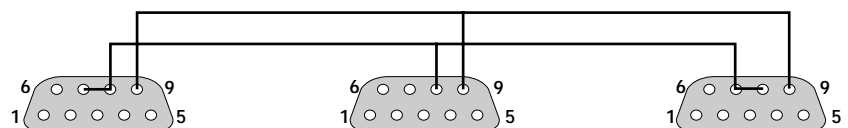

Connect terminals 7 and 8 when the monitoring system is at the end of the line.

The commands and messages reception syntax is dealt with in a special chapter (**Contact Alcatel**).

Installation of silencer heating kit



Consult the safety instructions (see B 00)

To avoid the condensation of pumped gases, and therefore, the clogging of the silencer during the pump operation with processes such as: Aluminum etching, Polysilicon, LPCVD or PECVD Nitrid, Alcatel proposes a silencer heating kit including:

- two heating belts (1)
- two insulation sleeves (2)
- a connection box (3)
- a mains cable (4).



Installation of silencer heating kit

Installation and electrical connection



During the silencer heating kit installation, take all the necessary precautions regarding the pumped gases before to open the exhaust circuit of the pump. Refer also to the safety instructions related to maintenance *Section D 00*.



The electrical power supply of the kit is not monitored by the M3 controller (in case of an emergency stop, the belt stays powered). Take the necessary precautions related to electrical safety.

- Remove the silencer from the pump.
- Install the two heating belts (1) using the tightening cords.



- Install the two insulation sleeves (2).

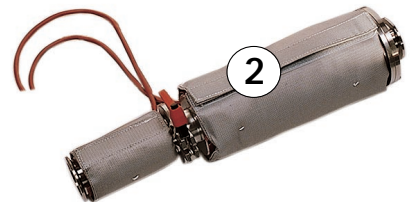

Check the electrical compatibility between the kit and the mains voltage.

- Remount the silencer on the pump.
- Connect the belts (1) to the power supply (3) after wiring the cables on the plugs if necessary (provided with the kit or recovered on the old belts in the case of maintenance).
- Connect the power supply (3) to the installation.
- Set the power supply switch to "I".

The heating kit will be used during pumping of condensable gases.



Caution : Heating temperature = 130 °C.
Take all the necessary precautions regarding burn risks.

Start-up of the M3 monitoring system



Study the safety instructions
(see B 00)

The keyboard is used to control the pump and configure the parameters.

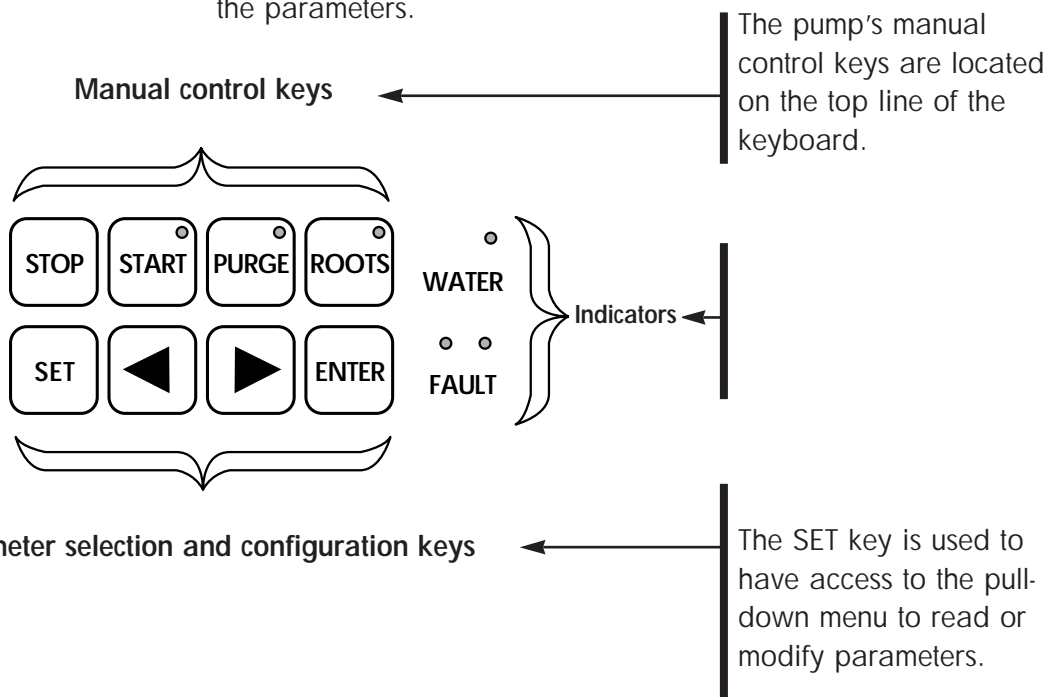

The functions of the parameter selection and configuration keys

Symbol	Description	Functions
	Parameter setting mode access key	<ul style="list-style-type: none"> Used to have access to the parameter setting mode Used to exit the various menus without validating the functions
 	Selection keys	<ul style="list-style-type: none"> Used have access to : <ul style="list-style-type: none"> - the next or previous menu - the next or previous parameter in the displayed menu Used to select or adjust the value of the parameter selected previously
	Configuration validation key	<ul style="list-style-type: none"> Used to validate the selection of a menu, parameter or value



An insulating film protects the keys. Do not use hard objects such as pens, screwdrivers, etc., which could damage the key.

Start-up of the M3 monitoring system

The M3 monitoring system has been configured in the factory according to the options and accessories defined during the order.

Setting / Observations

Power ON :
(Main switch of M3 to I)

Action / Observations

Display of the pump running time, the pump status and the date when the monitoring have been set for transport.

Display / Observations

```

75H          LOC N2
PUMPING STOPPED
02/02/98     11 : 32 : 54
    
```

Accessing to the parameter programming :

The programming made at the factory is protected by an access code which disables the entry of new parameters.

Press the key



```

M3 VERSION 2.03
-----
CODE : 0
    
```

Valid the code with the key



Access code can be personalized (see C 30)

Start-up of the M3 monitoring system

Setting / Observations

Initializing the equipment by updating the clock.

Action / Observations

Press the key repeatedly to have access to the **SETTING MENU**
Validate with the key



With the key move through the menu to **DATE/TIME**
Validate with the key



Decrease or increase the selected parameter using the keys



Validate the setting using the key
This action validates the setting and moves onto the next parameter



Validate the settings and return to the main menu with the key



Display / Observations

DEFINITION
SETTING MENU
MAINTENANCE MENU
OPERATING TIME

PURGE PRESS. SENSOR
SERIAL LINK
DATE/TIME
TEMPERATURE UNIT

DATE/TIME
MM/DD/AA HH: MM: SS
02/02/98 11 : 32 : 54

DEFINITION
SETTING MENU
MAINTENANCE MENU
OPERATING TIME

Set the STORAGE menu to save the internal parameters during transport or prolonged storage.

Press the key repeatedly to have access to the **STORAGE**
Validate with the key



Press the key



Pumping cannot be started
(Seconds counter is blocked)

MAINTENANCE MENU
OPERATING TIME
STORAGE
CHANGE CODING

STORAGE
PUMPING STOPPED
03/23/98 18 : 24 : 80

**Note : When you position the main switch to position I, the storage mode disappears automatically :
Make a DATE/TIME setting (see previous paragraph)**

Setting the M3 monitoring system parameters

Purpose of sensors

Purge sensor	<p>Signals insufficient gas purge during an alert time, and stops pumping at the end of the alarm time.</p> <p>Signals exhaust overpressure when the pressure reaches 1450 mbar (silencer clogged) and stops the pump at 1990 mbar.</p>
Gas Temperature sensor (Non TC version)	<p>Signals a gas temperature variation at the exhaust with :</p> <ul style="list-style-type: none"> - an alert 1 when the temperature is less than the alert 1 threshold - an alert 2 when the temperature is greater than the alert 2 threshold without stopping the group.
Pump Temperature sensor on TC version	<p>Allows to regulate ADP temperature.</p> <p>Signals a pump temperature variation (an alert when temperature is less than the alert threshold and an alarm when temperature is greater than alarm threshold).</p>
Motor power sensor	<p>Monitors the power consumed by the machine by generating an alert followed by an alarm as soon as the power is greater than each of its thresholds; the pump is stopped immediately when the alarm threshold is exceeded.</p>
E Analogic sensor	<p>Allows to monitor a voltage on an input contact with 2 adjustable thresholds.</p>
E1 and E2 logic sensors	<p>Allows to monitor a logic sensor during an alert time and stop pumping at the end of the alarm time.</p>

Setting the M3 monitoring system parameters

Summary table of monitoring parameters
Max. and Min. thresholds :

SENSORS	UNIT	THRESHOLD		FACTORY CONFIGURATION	
		Mini	Maxi	Alert	Alarm
Purge sensor	mbar min	600 0	900 60	860 0	Disabled
Gas temperature sensor	°C	0	170	{ < 20° > 160°	-
Pump θ° sensor (TC)*	°C	20	130	110	120
Motor power sensor	W	500	5000	2500	4000
E. analogical sensor	mV	0	10000	Disabled	Disabled
E1. logic sensor	min	0	60	Disabled	Disabled
E2. logic sensor	min	0	60	Disabled	Disabled

The pump may be started. The operation monitoring depends on the fault programming. However, the M3 monitoring system may be customized according to the current application, by programming the parameters, pump stopped, of the various menus listed on C 30.

*Temperature regulation occurs 10°C below the alert threshold.

M3 Monitoring system function table

DEFINITION



Other menus
next page

INLET VALVE OPTION
ANA. INPUT SELECT
E1 LOGIC INPUT
E2 LOGIC INPUT
SYSTEM SELECTION

AUTOMATIC RESTARTING
ROOTS CONTROL
BUZZER CONTROL SELECT.
PURGE CONTROL SELECT.
THERMO CONTROLLED
FLOW N2 OPTION

Initial configuration (bold)





Valid/**Disabled**
Valid/**Disabled**
Valid/**Disabled**
Valid/**Disabled**
ADS151/ADS301/ADS501/ADS801/1001
ADP81/ADP81V/ADP31/ADS501V
Valid/**Disabled**
Valid/**Disabled**
Valid/Disabled
Valid/Disabled
Valid/Disabled
Valid/Disabled

M3 Monitoring system function table

SETTING			
 <p>Other menus next page</p>	PURGE FLOW SENSOR	Alert time Alarm time	0 to 60 min/Disabled 0 to 60 min/Disabled
	TEMP. SENSOR	If Thermo controlled "Disabled": Alert 1 threshold Alert 2 threshold If Thermo controlled "valid": Alert threshold Alarm threshold	0 to Alert 2 Alert 1 to 170° C 20° to Alarm threshold Alert threshold to 130°C
	ADP POWER SENSOR	Alert threshold Alarm threshold	500 to Alarm threshold Alert to 5000 W
	ANA. INPUT SENSOR	Alert threshold Alarm threshold	0 to Alarm threshold Alert threshold to 10 000 mV
	E1 LOGIC. SENSOR	Alert time Alarm time	0 to 60 min/Disabled 0 to 60 min/Disabled
	E2 LOGIC. SENSOR	Alert time Alarm time	0 to 60 min/Disabled 0 to 60 min/Disabled
	PURGE FLOW PROLONGED	0 to 120 min	Initial config. : 10 min
	PURGE PRESS. SENSOR	600 to 900 mbar	Initial config. 860 mbar
	SERIAL LINK	Type Echo Address Speed Parity Stop bit	RS232/RS485/NETWORK Valid/Disabled 0 to 999 300 - 9600 Even/ None /Odd 1 or 2
	DATE, TIME	Time/Date menu	
	TEMPERATURE UNIT	Celsius/Fahrenheit	Initial config. : °C
	PRESSURE UNIT	mbar, hPa, Torr, PSI	Initial config. : mbar

(Technical modifications reserved)

M3 Monitoring system function table

<p>MAINTENANCE MENU</p> 	<p>MAINTENANCE TIME OVERHAUL ADP ADP LP BEARINGS INSPECT SILENCER OVERHAUL ROOTS</p>	<p>1000/34000 h 1000/17000 h 1000/17000 h 1000/34000 h</p>	<p>Initial Config : 8500 h 8500 h 2500 h 8500 h</p>
<p>OPERATING TIME</p>	<p>DISPLAY</p>		
<p>STORAGE</p>			
<p>CHANGE CODING</p>	<p>INPUT THE NEW CODE:</p>	<p>Using  and  key, input the new code and valide with </p>	
<p>LAST ALERTS</p>	<p>DISPLAY LAST 10 ALERTS</p>		
<p>LAST ALARMS</p>	<p>DISPLAY LAST 10 ALARMS</p>		
<p>CONFIGURATION</p>	<p>LIST OF CUSTOMIZED PARAMETERS</p>		

(Technical modifications reserved)

Use of the M3 monitoring for pumping operation



Check the rotational direction of the pump, upon first start-up
(See B 130)

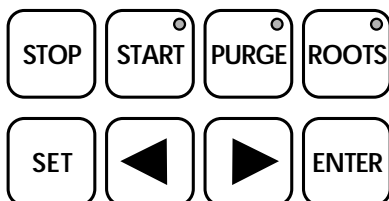

Study the safety precautions (voir B 00)



The performances and the operational safety of this product are guaranteed provided that it is used in normal operating conditions.

- Pre-adjustements :
 - to ensure a gas purge as soon as the pumping starts, set the "Select. CMD Purge" menu on disabled
 - to start-up or stop the gas purge during pumping set the "Select. CMD Purge" menu on valid. The purge will start or stop by pressing the "**PURGE**" key
 - to start-up the Roots at the same time as the ADP, set the "Roots control" menu on disabled
 - to start-up or stop the Roots while the ADP is running, set the "Roots control" menu on valid. The Roots will start or stop by pressing the "**ROOTS**" key.

- Start-up the pumping by pressing "**START**", the monitoring system performs the following operations :
 - opening the inlet valve (if preselection has been validated),
 - ADP pump start-up,
 - opening the water valve,
 - data capture and sensor processing,
 - opening the purge gas valve (if preselection has been validated),
 - Roots pump start-up.

At the same time the operating parameters are shown.

```
15 H *N2* ROOTS
CHECK PRESSURE 940 MBAR
GAS TEMP. / ADP TEMP
ADP POWER
```



The pumps are equipped with an exhaust pressure monitoring sensor. When this is not used, it is the responsibility of the user to prevent the risks related to excess pressure of the installation.

Use of the M3 monitoring for pumping operation

Operation monitoring

During operation, the user is warned of an operating incident by :

- one or more fault are displayed on the screen, alternating with monitoring parameters. When these faults are parameter programmable, the monitoring system triggers the alert phase followed by the alarm phase. The period for these phases is programmable.
- indicators light and buzzer sounded, if option selected.
- the fault contacts on the REMOTE connector at the rear of the monitoring unit are closed.
- pumping is stopped.

A list of incidents is given in the chapter D.



Avoid moving a pump in operation

Pumping shut-down

Press the “STOP” key, the monitoring system performs the following operations :

- pump stopping,
- water valve closing,
- injection of purge gas is continued during the shutdown phase (if programmed),
- when the pump is fitted with an exhaust valve or inlet valve, this valve is closed when pumping stops.

When the stoppage is caused by a power cut, automatic restarting is possible if “**AUTOMATIC RESTARTING**” has been enabled.





When the pump has been configured for automatic restart after a power failure, it is the responsibility of the user to take all the measures required to prevent risks resulting from this type of operation

Remote control

M3 monitor enables other operating modes, particularly control by PC via RS 232 interface and RS 485 (see *section B 150*) or the remote control via the connector Remote (see *section B 140*).

Use of the M1 monitoring system

 Study the safety precautions (see B 00)

 For the first pump start-up, check the rotational direction of the pump (see B 130)

Pump equipped with the M1 monitoring system and in local mode

- Set the main switch to I, actuate the **START** switch : the pumping starts, the water valve opens and the green indicator light goes on. (The hour counter is only increased when the pump is operating).
- Adjust the water flow rate (see section B 120).

Remote monitoring unit (M1)

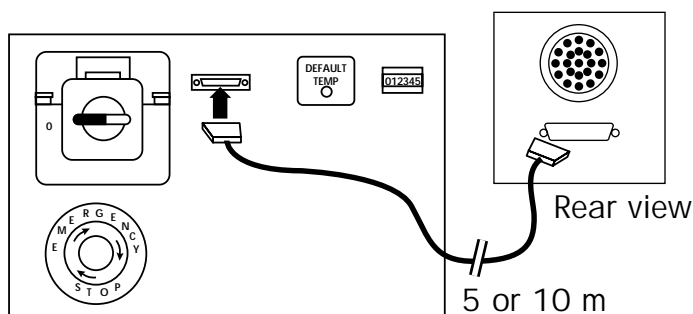

The remote monitoring unit is connected to the unit located on the frame via a 5 or 10 m cable, connected at the front. In this case, all controls are made from the remote unit. The frame-mounted unit only contains the main switch, the emergency stop and the monitoring system indicator lights.

Stopping pumping

Actuate the **STOP** switch, the water valve closes; the pumping stops.

 Avoid moving a pump in operation

Operating incidents

The user is informed of any incidents by :

- the fault indicator light which goes on (red),
- the audible warning buzzer,
- the fault contacts on the REMOTE connector at the rear of the monitoring system which close,
- stopping of the pumping although the STOP command has not been given.

Use of the M1 monitoring system

The M1 monitoring system can be remote controlled

The remote control function is performed by means of the "REMOTE" remote control connector at the rear of each fixed monitoring unit.

It is used for :

- The remote control of the pump "START/STOP/ Emergency Stop" functions.
- Copying monitoring parameters in dry contact form (250 V - 1 A - 100 VA). These contacts may be used for controlling automatic control systems. (*see section B 140*).

Safety instructions related to maintenance

This chapter describes the main preventive maintenance operations and provides a guide for first diagnosis in the event of an incident.



Standard precautions before any maintenance operation :
Before performing a maintenance operation, switch off the pump by setting the main switch to "0" and disconnect the mains cable.



CAUTION : before any operation, check the pumping conditions of the installation : toxicity, corrosion, possible radioactivity of the pumped gases.



Product tightness is guaranteed upon leaving the factory for normal operating conditions. It is the responsibility of the user to ensure that the level of tightness is maintained when pumping dangerous gases.

Depending on the case, we recommend :

- to purge the installation with dry nitrogen. The flush is performed automatically when the pump is stopped (normal stop, or due to a fault) if a maintained level of purge gas has been programmed. Otherwise, proceed as follows:
 - If the pump is remote controlled, remove the connections on the REMOTE connector, at the rear of the monitor, and connect the plug connector (supplied with the machine) instead.
 - Adjust the parameters of the M3 monitor and program a maintained level of purge gas for 10 minutes.
 - Press START, followed by STOP on the front panel. The flush is performed after the machine is stopped.
- to wear gloves, protective glasses and, if necessary, a breathing mask.
- to ventilate the premises well.
- not to dispose of residue but, if necessary, to have it destroyed by a qualified organization.

Safety instructions related to maintenance

- Certain gases can become corrosives and toxic when trapped in oil. Always wear protective gloves when handling used and dirty pump oil, drain it into a closable container, and do not breathe the fumes of the oil. Always use fully self-contained breathing apparatus.
- When the silencer is maintained, avoid any contact with the reaction by-products (deposit, powder..) strongly corrosive: wear gloves even a breathing mask. Cleaning procedure can produce violent reactions and dangerous gas releases. We recommend to ventilate the premises well and disassemble the equipment under a suction hood.
- Always dispose of used dirty oil, or sub-products properly and in compliance with all local, state and federal environmental laws and regulations.



After a complete maintenance operation, on the pump or on the installation, it is recommended to perform a tightness test with helium.

First level of maintenance



Study the safety instructions related to maintenance (See D 00).

When a problem occurs, the user is informed by :

- the relevant fault indicator light which goes on,
- the audible warning buzzer,
- the fault contacts on the REMOTE connector at the rear of the monitoring system which close,
- the stopping of the pumping although the STOP command has not been given,
- the display of fault message on the screen of the M3 monitoring system,
- a message via the RS 232 or RS 485 link on a micro-computer.

Location of electrical components

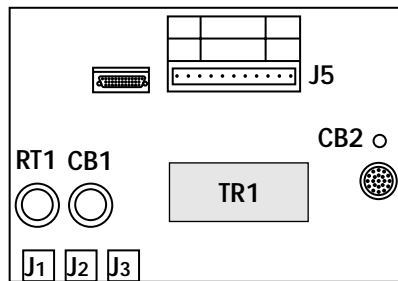

M1 Monitoring unit (Rear panel)

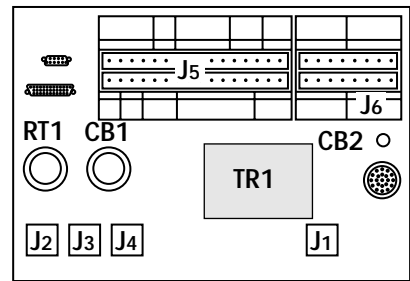

M3 Monitoring unit (Rear panel)

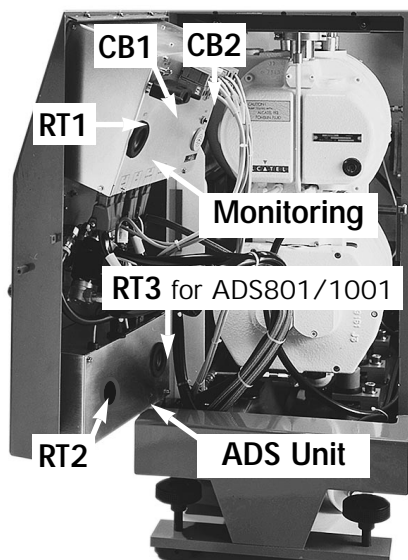

- CB1** : circuit breaker
- CB2** : Ext* 24V circuit breaker
- RT** : ADP and Roots power circuit breakers
- TR1** : Int* transformer
- * Int : internal

ADS opened

First level of maintenance

Preventive maintenance with monitoring system M1

The overall operating time of the machine can be read on the front of the monitoring units (M1). This is also used to calculate the operating time of the various components which require maintenance.

The replacement frequency of certain components depends directly on the type of process used. *(See section D 20)*

Maintenance time monitoring with monitor system M3

Depending on the maintenance parameters programmed, when the operating time before maintenance has expired, the screen display alternates between operating parameters and the message "ALERT MAINTENANCE", the "FAULT" indicator is lit.

Press the "SET" button during pumping and the operating times for components are displayed in turn.

This information can be read at any time using the "Operating time" menu. Perform maintenance on the relevant parts.

Maintenance operations

See Section E

Maintenance frequency

For processes 1 (See section B 120)

	Description	8500 H	13000 H	25000 H	Time required	Equipment required		Specific tool	Comments
						Description	Part number		
A ADP 31 - ADP 81	LP bearing replacement				30 min	Minor kit (31/81)	090576	Consult Alcatel	
	Full overhaul				10 H* 12 H*	Major kit (31) Major kit (81) ALCATEL 113 oil (0.5 L)	040162 061925 064657	Consult Alcatel	**
B Roots 151 - 301 - 601	Full overhaul				8 H*	Major kit (151) Major kit (301/601) ALCATEL 113 oil (0.5 L) Qty : 2 for 301 & 601	100068 090839 064657	051940	2 oil fillings for 301 et 601 **
C Roots 1001/1501	Full overhaul				12 H*	Major kit ALCATEL 113 oil (0.5 L) Qty : 6	101109 064657		6 oil fillings **

A : ADP 31 - ADP 81 Maintenance

A+B : ADS 151 / 301 / 501 Maintenance

A+C : ADS 801/1001 Maintenance

* Testing and cleaning time not included

** For oil filling, see section B 50

Maintenance times can change according to processes and equipments used.

Maintenance frequency

For processes 2 (See section B 120)

	Description	4200 H	8500 H	17000 H	Time required	Equipment required		Specific tool	Comments
						Description	Part number		
A ADP 31 - ADP 81	Silencer cartridge control (1)				15 min	Silencer cartridge	040095		Equipped silencer available Ref : 100210
	LP bearing replacement				30 min	Minor kit (31/81)	090576	Consult Alcatel	
	Full overhaul				10 H* 12 H*	Major kit (31) Major kit (81) ALCATEL 113 oil (0.5 L)	040162 061925 064657	Consult Alcatel	**
B Roots 151 - 301 - 601	Full overhaul				8 H*	Major kit (151) Major kit (301/601) ALCATEL 113 oil (0.5 L) Qty : 2 for 301 & 601	100068 090839 064657	051940	2 oil fillings for 301 et 601 **
C Roots 1001 - 1501	Full overhaul				12 H*	Major kit ALCATEL 113 oil (0.5 L) Qty : 6	101109 064657		6 oil fillings **

A : ADP 31 - ADP 81 Maintenance

* *Testing and cleaning time not included*

A+B : ADS 151 / 301 / 501 Maintenance

** *For oil filling, see section B 50*

A+C : ADS 801/1001 Maintenance

Maintenance times can change according to processes and equipments used.

(1) With TC version and silencer heating, the maintenance of the silencer can be extended to 8500 h.

Maintenance frequency

For processes 3 (See section B 120)

	Description	2100 H	4200 H	8500 H	Time required	Equipment required		Specific tool	Comments
						Description	Part number		
A ADP 31 - ADP 81	Silencer cartridge control				15 min	Silencer cartridge	040095		Equipped silencer available Ref : 100210
	LP bearing replacement				30 min	Minor kit (31/81)	090576	Consult Alcatel	Included in full overhaul
	Full overhaul				10 H* 12 H*	Major kit (31) Major kit (81) ALCATEL 113 oil (0.5 L))	040162 061925 064657	Consult Alcatel	**
B Roots 151 - 301 - 601	Full overhaul				8 H*	Major kit (151) Major kit (301/601) ALCATEL 113 oil (0.5 L) Qty : 2 for 301 & 601	100068 090839 064657	051940	**
C Roots 1001 - 1501	Full overhaul				12 H*	Major kit ALCATEL 113 oil (0.5 L) Qty : 6	101109 064657		**

A : ADP 31 - ADP 81 Maintenance

A+B : ADS 151 / 301 / 501 Maintenance

A+C : ADS 801/1001 Maintenance

* Testing and cleaning time not included

** For oil filling, see section B 50

Maintenance times can change according to processes and equipments used.

Diagnosis and troubleshooting

- Pump does not start **D 40** ➤

- The pump is running and then is showing
an alert or alarm message
(followed by the pumps stopping) **D 50** ➤

- The pump is running (no message) **D 60** ➤

Pump does not start

INCIDENT	CAUSE	TROUBLESHOOTING
<p>The display is not lighting up or no display</p>	<p>No mains</p>	<p>Check power supply</p>
	<p>NO</p>	
	<p>Isolating switch is off</p>	<p>Switch it on Version before 96/12: Push on the red button until zero and release.</p>
	<p>NO</p>	<p>Since 97/01 Push on the blue button until zero.</p>
	<p>CB1 breaker switched off</p>	<p>Check the calibration Switch it on</p>
<p>The keyboard is not working</p>	<p>NO</p> <p>Other problem</p>	<p>Call Alcatel customer service</p>
		<p>Call Alcatel customer service</p>

Pump does not start

INCIDENT	CAUSE	TROUBLESHOOTING
<p>Pressing on "Start" does not start-up the pump</p> <p>Roots is not running</p>	<p>Bad M3 configuration</p>	<p>Configure for "ADS" and/or disable Roots</p>
	<p>NO</p> <p>Command "Roots valid" not programmed</p>	<p>Check the setting</p>
	<p>NO</p> <p>Press on key "Roots"</p>	
<p>Roots does not run and "Roots" message is displayed</p>	<p>No * presence near Roots</p>	<p>Check presence or connect jumper plug RP</p>
	<p>NO</p> <p>"Roots" J3 plug bad connected</p>	<p>Check the connection</p>
	<p>NO</p> <p>Problem on M3</p>	<p>Call Alcatel customer service</p>
<p>ADP does not run</p>	<p>"ADP" plug bad connected</p>	<p>Check the connection</p>
	<p>NO</p> <p>Defective management board</p>	<p>Call Alcatel customer service</p>

Edition 04 - May 98

Pump does not start

INCIDENT	CAUSE	TROUBLESHOOTING
Messages on the display		
Message "STOCK"	Pump in storage mode	Set the main switch on "0", then set it again on "1".
Message "REM"	<div data-bbox="596 898 999 1043" style="border: 1px solid black; padding: 5px;"> <p style="text-align: center;">On Remote mode No RP plug or bad connection</p> </div> <p style="text-align: center;">NO</p> <div data-bbox="596 1137 999 1245" style="border: 1px solid black; padding: 5px;"> <p style="text-align: center;">Problem on M3</p> </div>	<p>Check the connection of J7. See section B 140.</p> <p>Call Alcatel customer service</p>
Alarm "Breaker KM2"	<div data-bbox="596 1435 999 1514" style="border: 1px solid black; padding: 5px;"> <p style="text-align: center;">Roots KM2 Contactor</p> </div> <p style="text-align: center;">NO</p>	<p>Check the condition and the connection of the contactor (See D 70).</p>
Alarm "Breaker RT1"	<div data-bbox="596 1603 999 1682" style="border: 1px solid black; padding: 5px;"> <p style="text-align: center;">ADP RT1 breaker</p> </div> <p style="text-align: center;">NO</p>	<p>Switch it on. Check its rate. (See D 70). Check ADP mechanical condition.</p>
Alarm "Breaker RT2"	<div data-bbox="596 1805 999 1883" style="border: 1px solid black; padding: 5px;"> <p style="text-align: center;">Roots RT2 breaker</p> </div> <p style="text-align: center;">NO</p>	<p>Switch it on. Check its rate. (See D 70). Check ADP mechanical condition.</p>
See next page 4/4		

Pump does not start

INCIDENT	CAUSE	TROUBLESHOOTING
Alarm "Breaker KM1"	<div style="border: 1px solid black; padding: 5px; text-align: center;"> ADP KM1 Contactor </div> <p style="text-align: center;">NO</p>	Check the condition and the connection of the contactor (<i>See D 70</i>).
Alarm "Breaker EMO"	<div style="border: 1px solid black; padding: 5px; text-align: center;"> Emergency switch </div> <p style="text-align: center;">NO</p>	Switch it on (<i>See D 70</i>).
Alarm "Pressure"	<div style="border: 1px solid black; padding: 5px; text-align: center;"> Exhaust pressure ≥ 1450 mbar </div>	<i>See D 80</i>
"Starting phase"	<div style="border: 1px solid black; padding: 5px; text-align: center;"> Main power is not correct </div>	Check the main power.
No message displayed on the screen	<div style="border: 1px solid black; padding: 5px; text-align: center;"> Problem on M3 </div>	Call Alcatel customer service

The pump is running and then is showing an alert or alarm message (followed by the pump stopping)

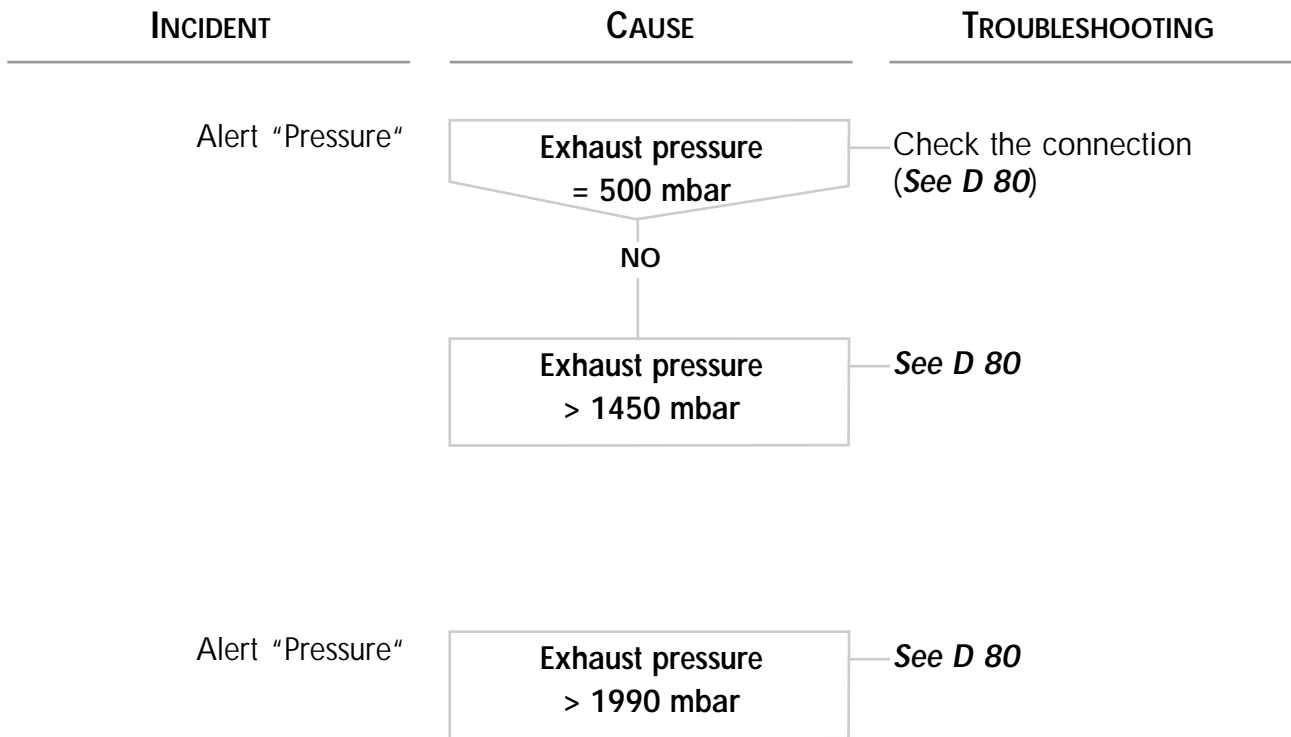

The pump is running and then is showing an alert or alarm message (followed by the pump stopping)

INCIDENT	CAUSE	TROUBLESHOOTING
"Gas Temp." Alert	θ gas lower than alert threshold 1	See D 90
	NO	
	θ gas higher than alert threshold 2	See D 90
	NO	
	Sensors not connected θ gas = 170°C	Check the connection
	NO	
	Problems on platinumium sensor	See D 90
"Consumption" Alert "Consumption" Alarm	Consumption higher than alert threshold or no power	See D 100

The pump is running and then is showing an alert or alarm message (followed by the pump stopping)

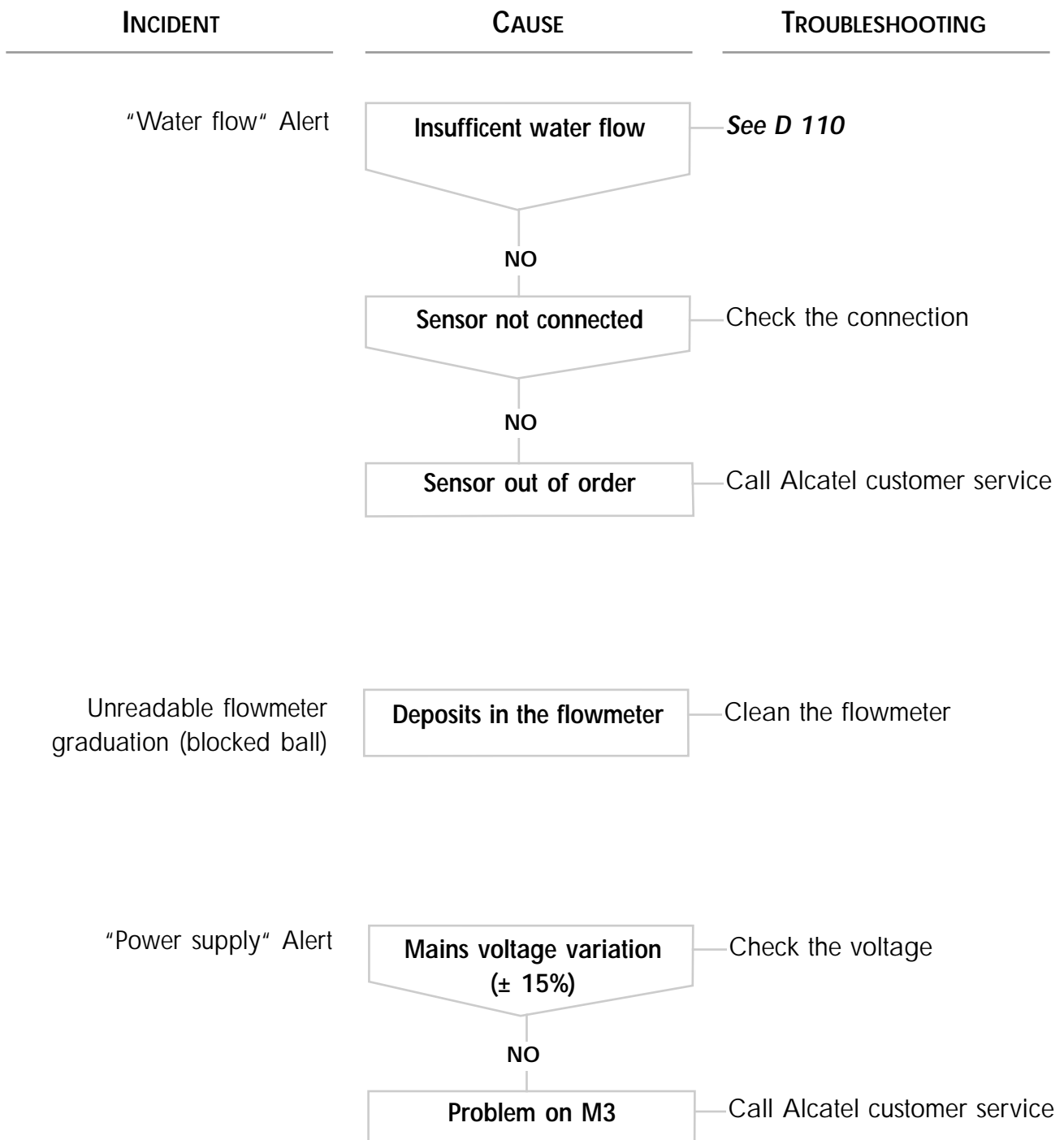

The pump is running and then is showing an alert or alarm message (followed by the pump stopping)

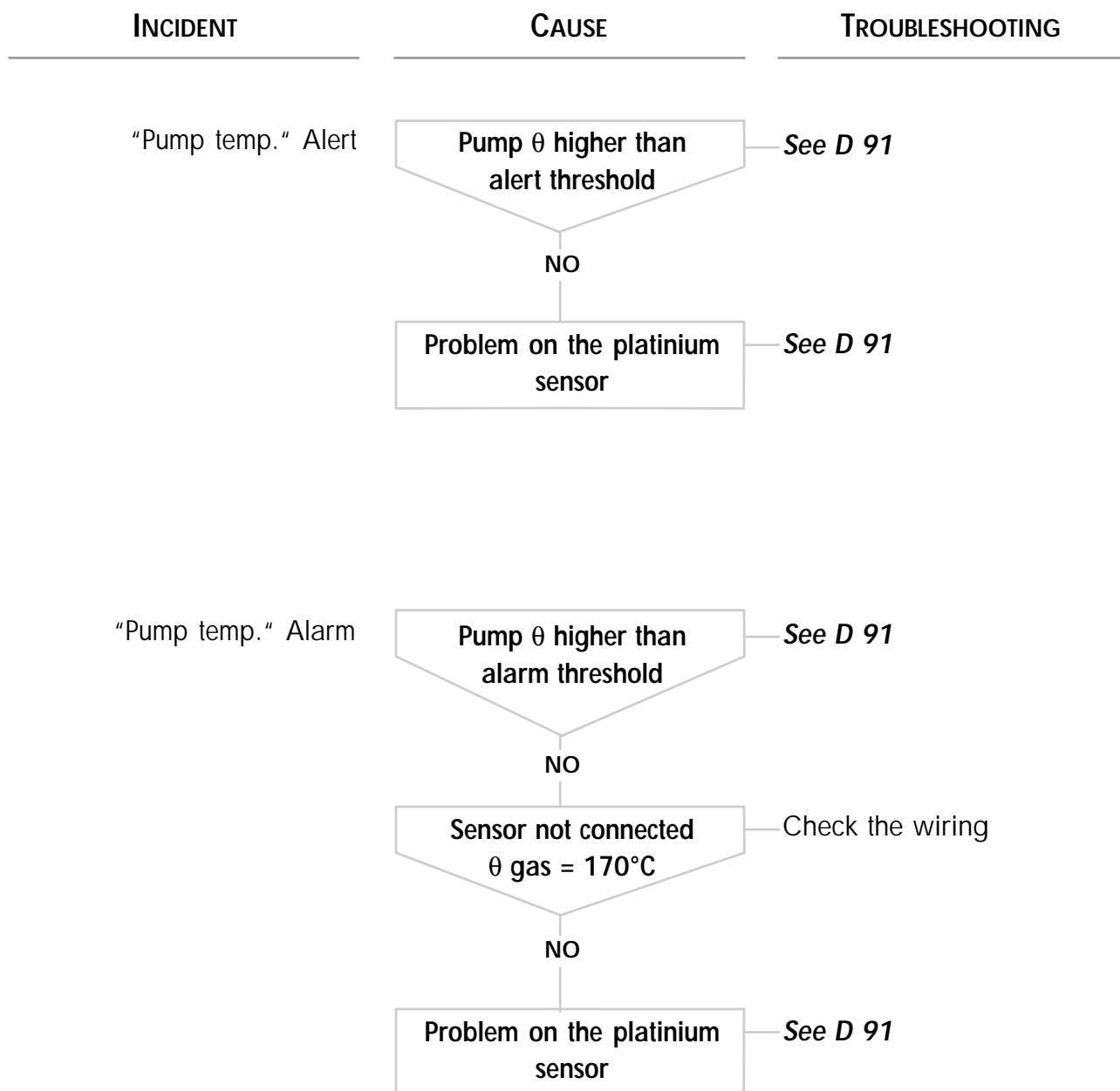

The pump is running and then is showing an alert or alarm message (followed by the pump stopping)

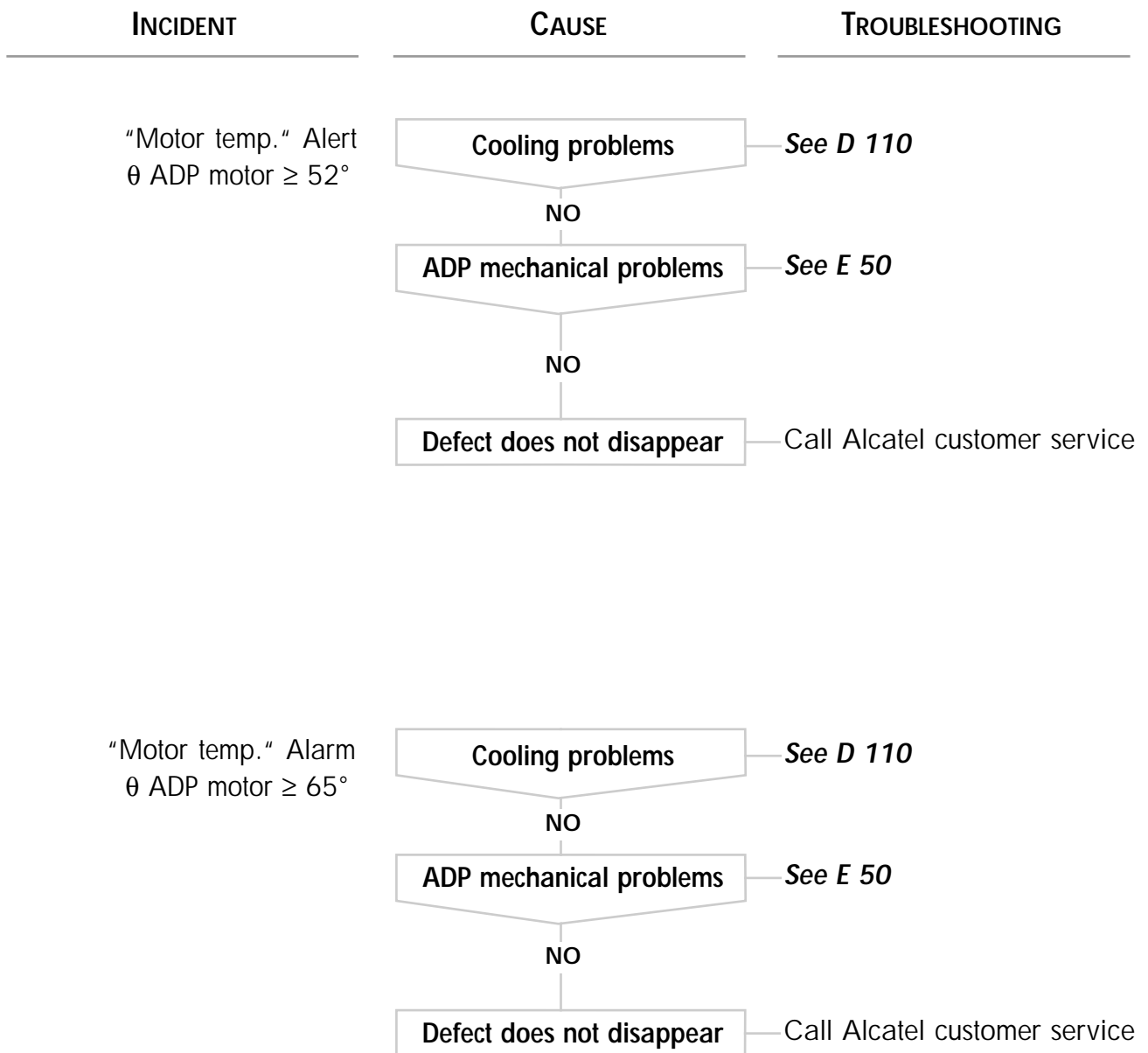

The pump is running and then is showing an alert or alarm message (followed by the pump stopping)

INCIDENT	CAUSE	TROUBLESHOOTING
<p>Alert or alarm "Purge N2"</p> <p>Alert and alarm are switched on according to the delays programmed in M3 configuration</p>	<p>Without flow purge sensor option</p> <pre> graph TD A[Exhaust pressure P = 500 mbar] -- NO --> B[500 mbar < P < Pres. threshold] </pre>	<p>See D 80</p>
<p>With flow purge sensor option</p>	<pre> graph TD A[No nitrogen] -- NO --> B[Flowmeter bad set] </pre>	<p>See D 80</p>

The pump is running and then is showing an alert or alarm message (followed by the pump stopping)

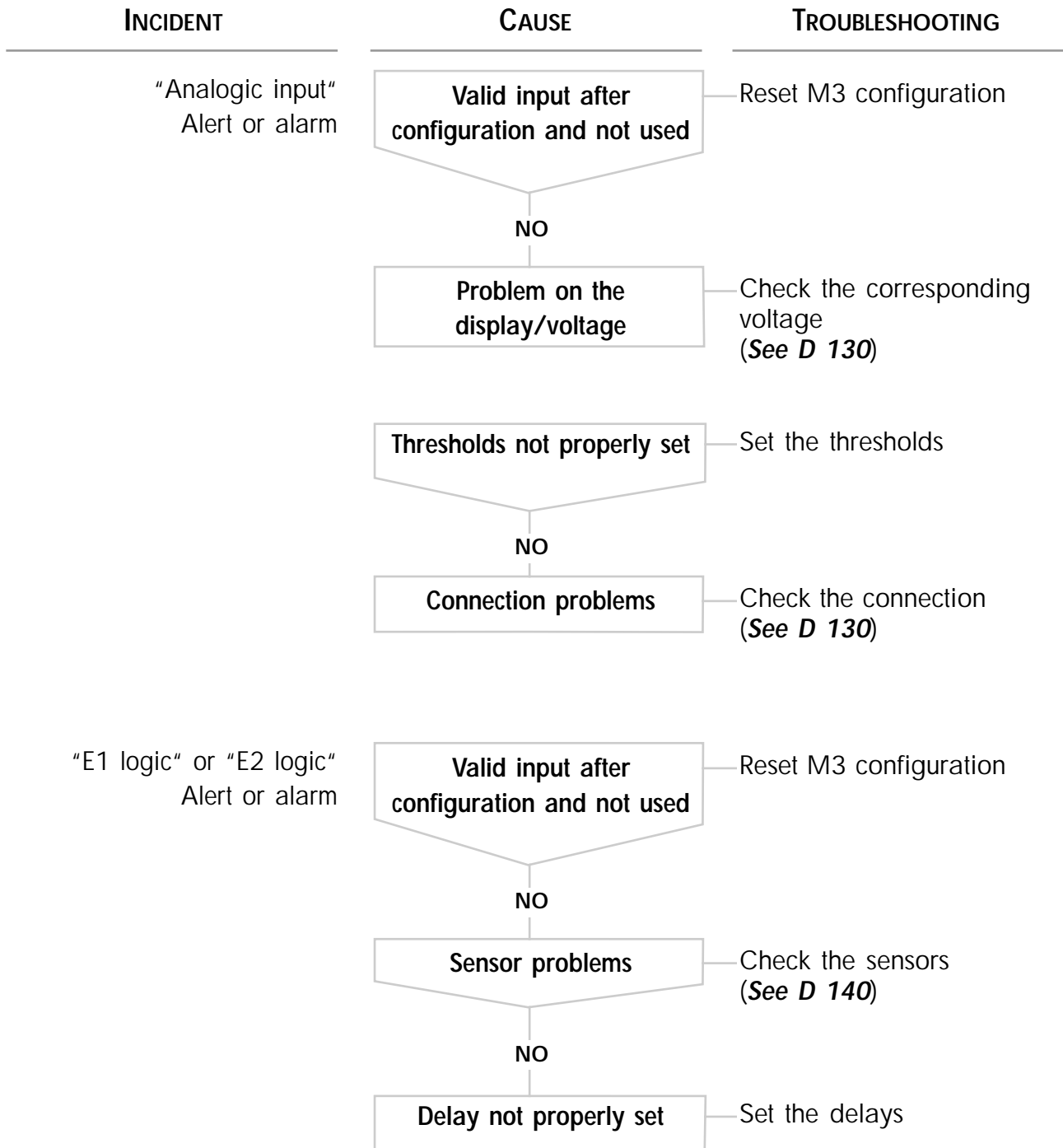

The pump is running and then is showing an alert or alarm message (followed by the pump stopping)

INCIDENT	CAUSE	TROUBLESHOOTING
"Valve option" Alert	Valid option after configuration and not used	Reset M3 configuration
	NO	
	Valve does not close when pump is stopping	Check the compressed air supply. Check the valve condition.
	NO	
	Contact problems	See D 150
"Valve option" Alarm	Valid option after configuration and not used	Reset M3 configuration
	NO	
	Valve does not open when pump is starting	Check the compressed air supply. Check the valve condition.
	NO	
	Contact problems	See D 150

Edition 04 - May 98

The pump is running and then is showing an alert or alarm message (followed by the pump stopping)

INCIDENT	CAUSE	TROUBLESHOOTING	
<p>"Variator" Alert</p>	<p>Valid option (ADP 81V, ADS 801/1001 or ADS 501V) when it is not necessary</p>	<p>Reset M3 configuration.</p>	
	<p>NO</p>	<p>Pump is stopped</p>	<p>Check variator parameter on ADS 801. (See D 160)</p>
	<p>NO</p>	<p>Wiring problems</p>	<p>Check the connection. (See D 160)</p>
<p>"Maintenance" Alert (ADP, Bearings, Silencer or Roots)</p>	<p>The maintenance threshold of a parameter is reached</p>	<p>Perform maintenance operation and reset the corresponding time. Check the maintenance thresholds.</p>	

The pump is running - No message

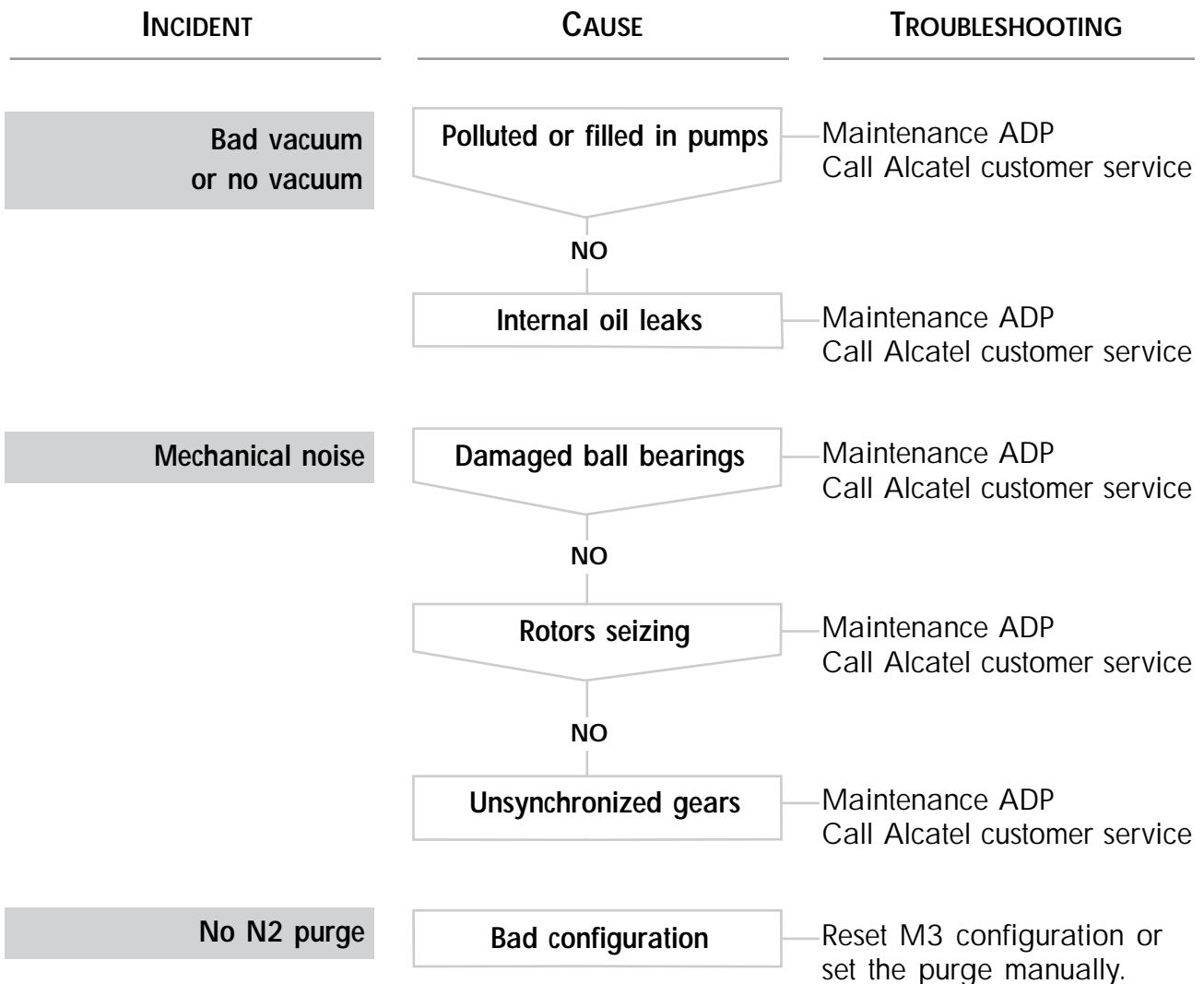

“Breaker ...” Alarm

“Breaker KM2” Alarm Roots KM2 Contactor

- Check the breaker CB2, on M3 rear panel
- If the message still remains, call Alcatel customer service

“Breaker RT1” Alarm ADP RT1 Breaker

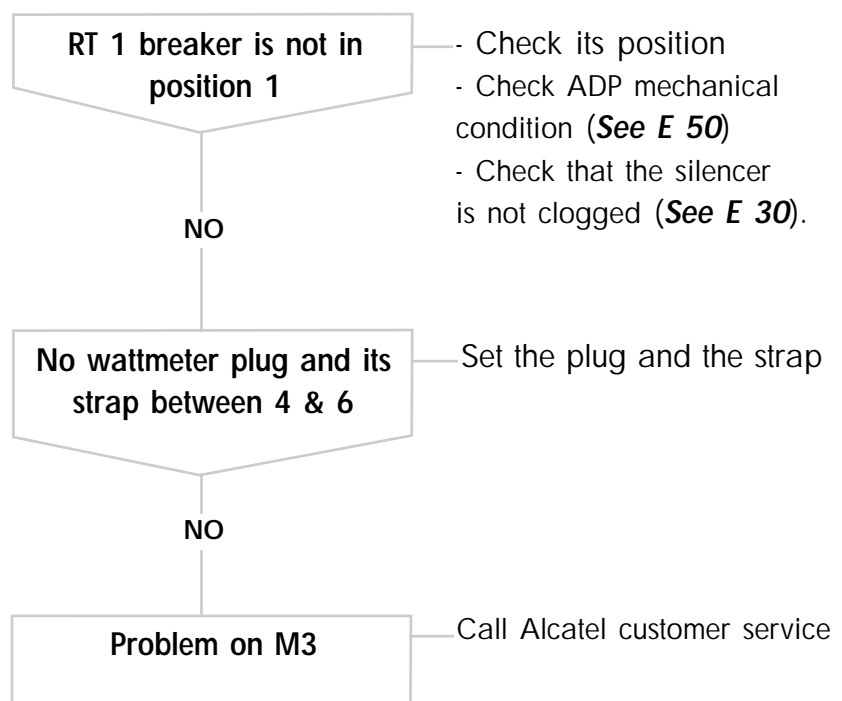

“Breaker RT2” Alarm RT2 Roots breaker

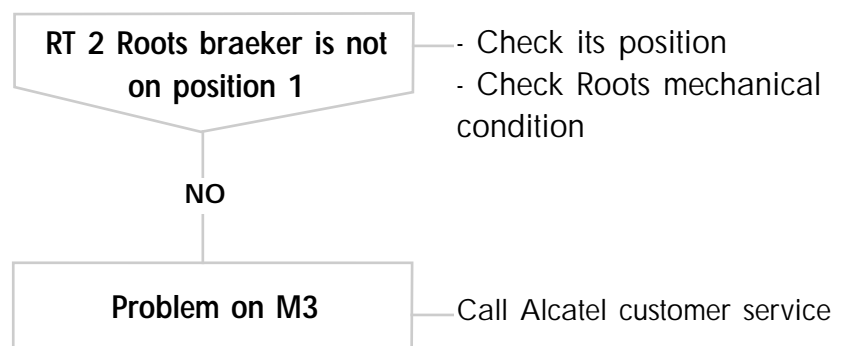

“Breaker ...” Alarm

“Breaker KM1” Alarm ADP KM1 contactor

- Check CB2 breaker at the rear of M3. (see **D 10**).
- Check the strap presence between the pins 41, 42, 43 and 44 on remote plug. (see **B 140**).
- If the defect still remains, call Alcatel customer service.

“Breaker EMO” Alarm Emergency stop

- Check that the emergency stop button is not tripped (unlock it by rotating 1/4 of turn).
- If the defect still remains, call Alcatel customer service.

“Pressure” Alert and alarm

“N2 Purge” Alert and alarm

Exhaust pressure higher than threshold “Pressure” Alert and alarm

- Check the nitrogen pressure setting according to section B 120.
- Check that the silencer, the pipe to exhaust are not clogged.
- If the defect still remains, call Alcatel customer service.

“Pressure” Alert and alarm “N2 Purge” Alert and alarm

Exhaust pressure level
between 500 mbar and
threshold set
“N2 Purge” Alert and alarm

Without Nitrogen flow sensor option

- Either check the connection, the display and nitrogen pressure setting (idem exhaust pressure too high *see page 1/2*).
- If there is no N2 pressure, check nitrogen supply, connections, electrovalve and the coil and its connection.
- If the incident is still present, there is another problem on the M3: call Alcatel customer service.

With Nitrogen flow sensor option

(The flowmeter is connected
instead if E2. Log.)

- Check nitrogen supply, electrovalve and its coil.
- Check the nitrogen detector setting.
- Check the nitrogen detector wiring by shunting pins 23 & 24 of J5.

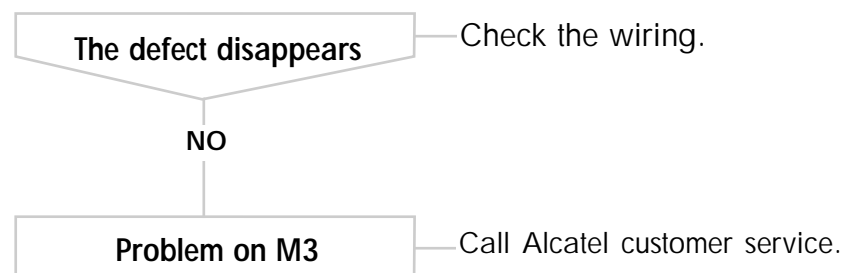

Exhaust pressure
= 500 mbar

Check that the sensor is properly connected.

- Test the connection and the display (idem exhaust pressure too high *see page 1/2*).
- If the incident is still present, call Alcatel customer service.

“Gas temp.” Alert

- Check the thresholds.
- Check the flowrate, the kind and the concentration of pumped gases.
- Check that the exhaust pipe is not clogged.
- Check the display :
 - θ ambient when pump is stopped.
 - θ : 100°C in continuous operation.
- Check the wiring and the sensor : the resistance between pins 1 & 2 of J6 must be between 100 and 160 Ω .
(J6 unplugged)
 - 0°C : 100 Ω
 - 20°C : 107,8 Ω
 - 50°C : 119,4 Ω
 - 80°C : 130,9 Ω
 - 100°C : 138,5 Ω
 - 157°C : 160 Ω
- If the sensor is OK, there is another problem on the M3:
call Alcatel customer service.

“Pump temp.” Alert

- Check the thresholds.
- Check the display :
 - θ ambient when pump is stopped.
 - θ : 100°C in continuous operation.
- Check the wiring and the sensor : the resistance between pins 1 & 2 of J6 must be between 100 and 160 Ω .
(J6 unplugged)
 - 0°C : 100 Ω
 - 20°C : 107,8 Ω
 - 50°C : 119,4 Ω
 - 80°C : 130,9 Ω
 - 100°C : 138,5 Ω
 - 157°C : 160 Ω
- Check the cooling circuit.
- If the sensor is OK, there is another problem on the M3:
call Alcatel customer service.

“Consumption” Alert and alarm

Consumed power higher than alert or alarm thresholds

- Check the threshold setting.
- Check the flowrate, the kind and the concentration of pumped gases.
- Check that exhaust pipe are not clogged.
- Check that there is no mechanical problem (seizing), or filling in in the pumping line.
- Check LP bearings.
- Check the rotational direction of the pump.
- If the incident is still present, call Alcatel customer service.

Consumed power = 0 W

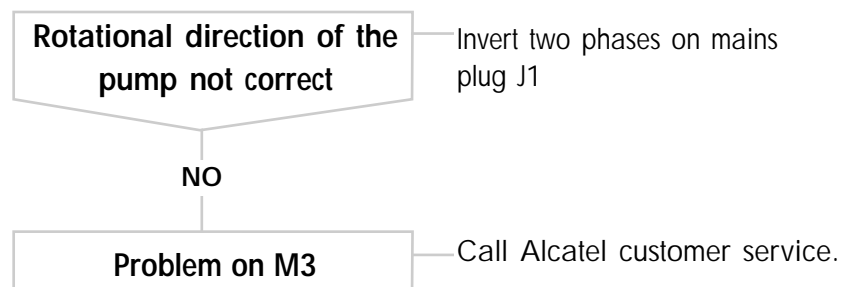

“Water flowrate” Alert

CAUSE	TROUBLESHOOTING
Insufficient water flow	<ul style="list-style-type: none"> - Check the flowmeter setting according to section B 120. - Check that the electrovalve, the flowmeter or the pipes are not clogged. - Check that there is no leak.
No water flow	<ul style="list-style-type: none"> - Either check the water supply and the connections. - Check the connection and the water valve coil condition.

Water flow OK

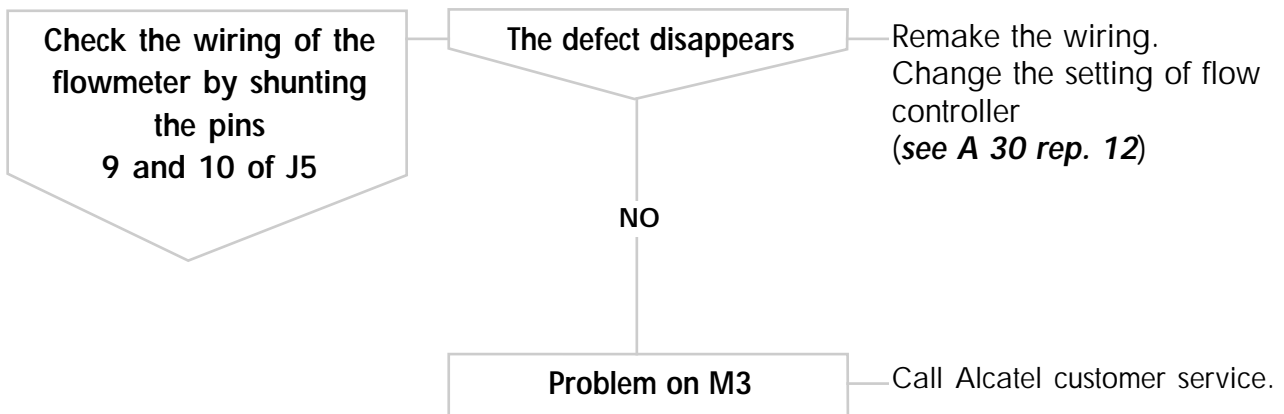

Edition 04 - May 98

“Motor temp.” Alert or alarm

ADP motor temperature higher than the thresholds

- Check the water flowrate in the pump (see **D 110**).
- Check the motor temperature.

Case of an alert

- Check the sensor and the wiring by shunting pins 21 & 22 of J5.

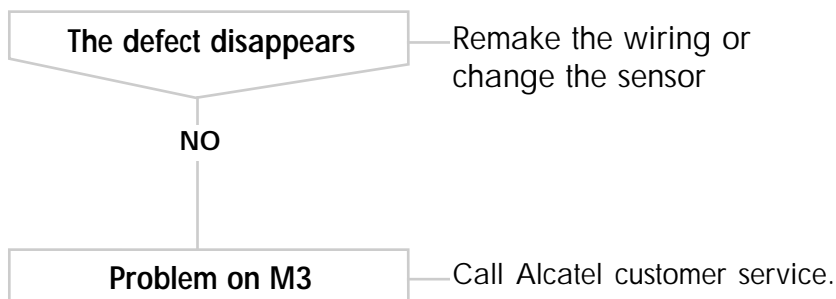

Case of an alarm

- Check the sensor and the connection by shunting pins 19 & 20 of J5.

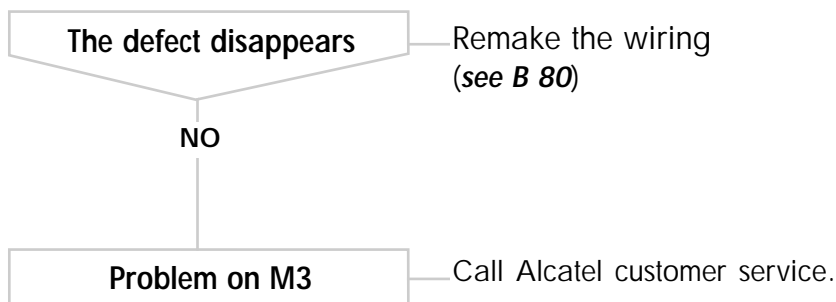

"Analogic input" Alert or alarm

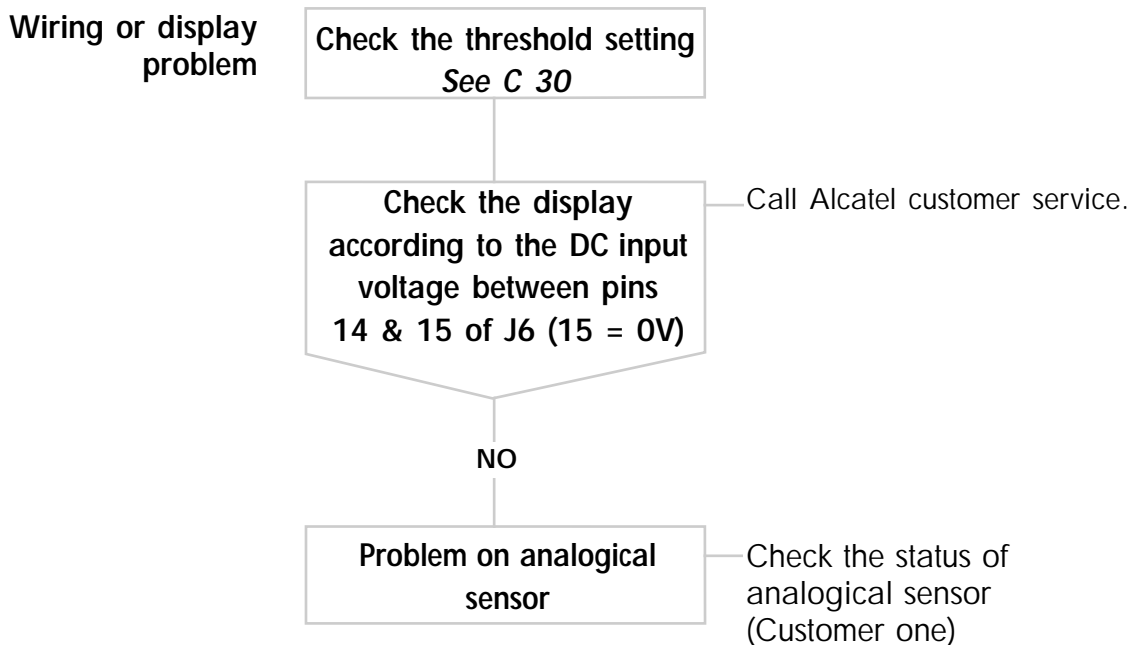

“E1 logic” Alert or alarm or “E2 logic” Alert or alarm

Sensor or connection problem Check the threshold setting *See C 30*

E1 logic Shunt the sensor

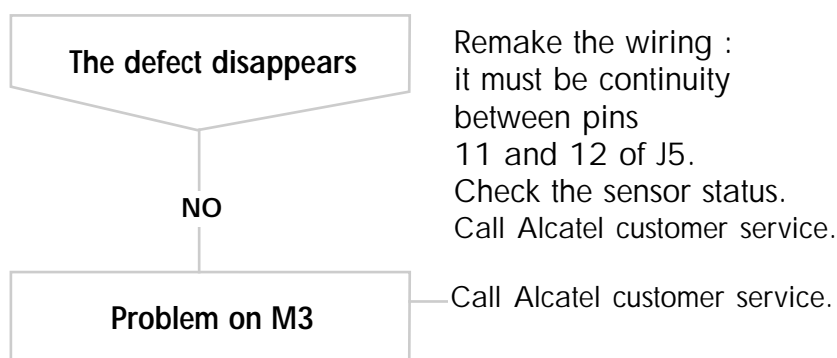

E2 logic Unplug the sensor

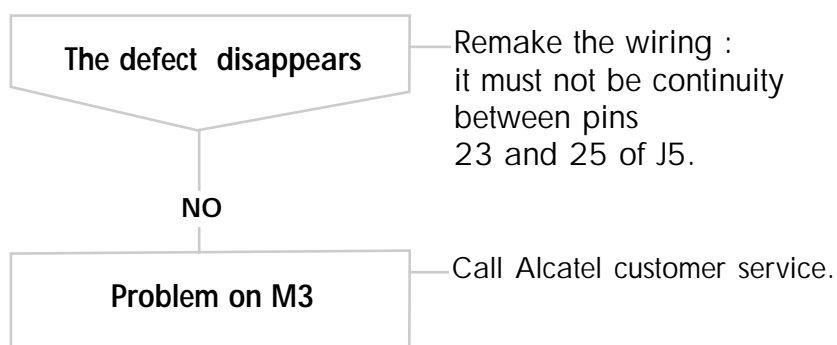

“Valve option” Alert and alarm

Contact problem Check the configuration of M3 parameters (**See C 30**)

Alert Check the wiring by shunting pins 7 & 8 of J5.

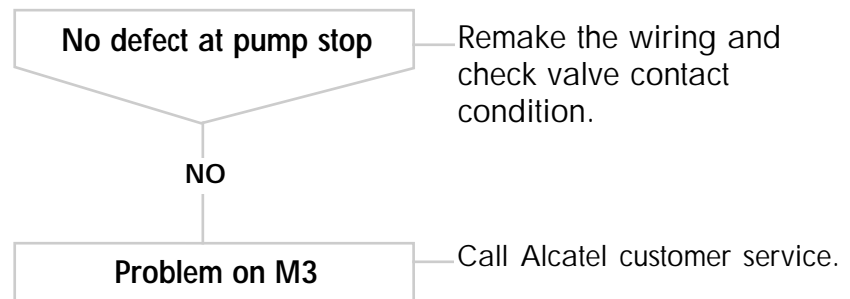

Alarm Check the wiring by shunting pins 5 & 6 of J5.

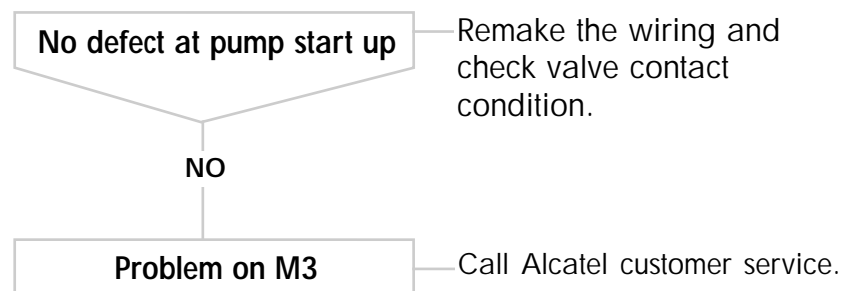

“Variator” Alarm

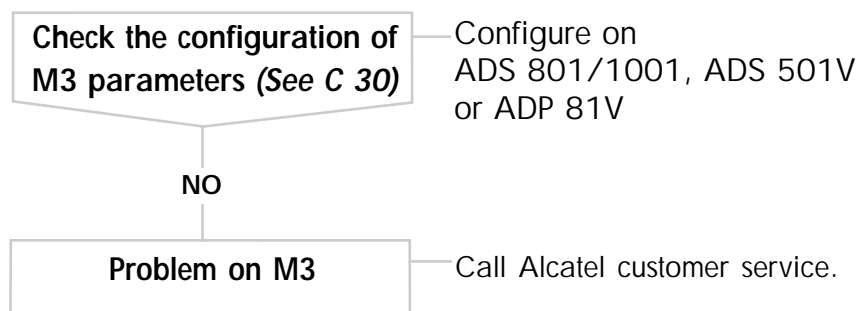

Pump draining (Roots : front and rear casings)

Study the safety precautions before intervention. (See sheet D 00)

! Certain gases become corrosive and toxic when trapped in oil.
Always wear protective gloves when handling used and dirty pump oil, drain into a closable container, and do not breathe the fumes of the oil. Always use fully self-contained breathing apparatus.

! Always dispose of used or dirty oil, or sub-products properly and in compliance with all local, state and federal environmental laws and regulations.

Housing oil replacement:

10 Unfasten the fill plug in order to eliminate any excess pressure in the housing.

10 Remove the drain plug and allow the used oil to flow into a container (capacity: 0.5 litre).

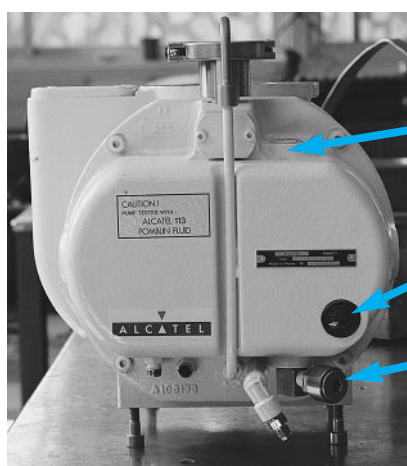

ROOTS

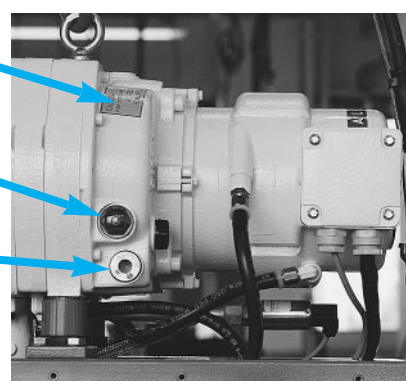

ADP

! Caution: the Roots is equipped with 2 housings. Repeat the operation for each housing.

Replace the drain plug and the remove the fill plug.

Introduce the quantity of new oil required **(see Section B 50)**.

Silencer maintenance

Consult the standard precautions before intervention - see Section D 00

For quicker interventions and special precaution during cleaning, it is recommended to replace all the parts (equipped silencer and outlet tube) and repair the replaced parts on a bench.

 **When the silencer is maintained, avoid any contact with the reaction by-products (deposit powder..) strongly corrosive : wear gloves even a breathing mask.**

REPLACEMENT FREQUENCY

The ADP pump silencer repair work frequency depends on the process used. Refer to the maintenance frequency tables.

■ **See Section D 20**

SILENCER REPLACEMENT

 Remove the side covers ■ **See section B 20** and remove the silencer backplate located on the rear panel of the pumping unit.

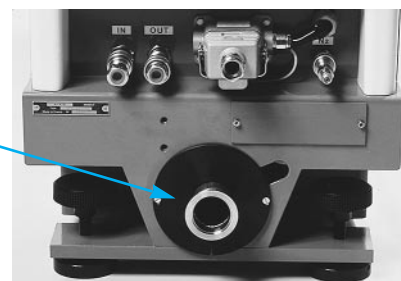

Disconnect the silencer from the pump exhaust connector by removing the clamping ring and the seal support ring. (Access via one of the side openings located at the bottom of the frame)

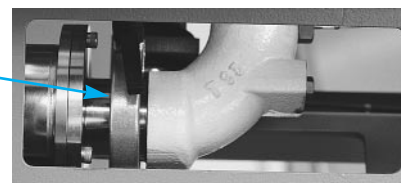

Remove the assembly (silencer and outlet tube) from the rear of the machine.

 Reinstall a complete assembly (equipped silencer and outlet tube).

Reinstall the backplate to the rear of the pumping unit and the side covers. Perform the maintenance of the replaced parts on a bench.

SEE FOLIO 2 

Silencer maintenance

Refer to the special precautions before any intervention - see Section D 00

PART CLEANING AND CARTRIDGE REPLACEMENT

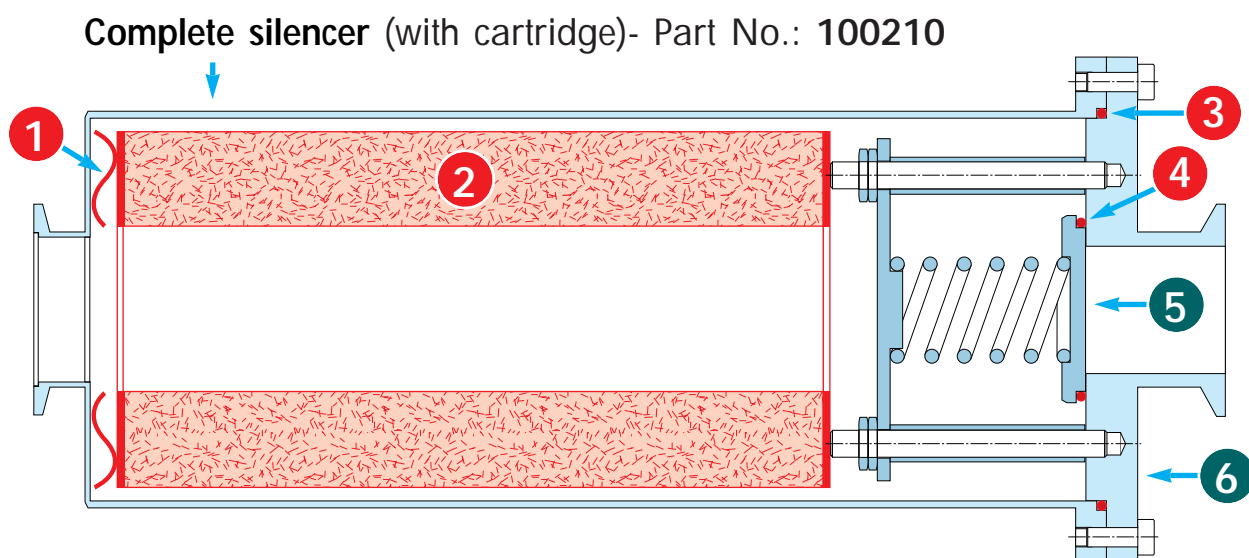

■ Parts to be replaced

Silencer maintenance kit Part No. 040095 (items 2, 3, 4)

- 4** Separate the outlet tube from the silencer.
Remove the cover assembly.

Soak the silencer body in a bath of hot water and remove the deposit located inside the silencer.

Remove the cartridge and the Borrelly washer.

Loosen and remove the lock-nuts and the nuts to release the stop valve (5).

Remove the two O-rings (3 and 4).

Clean all the parts in a bath of hot water using a cloth if necessary.

Dry in the air or with compressed air.













Position the Borrelly washer (1) and install a new cartridge.

Reassemble the other parts by replacing the O-rings (3 and 4) with new seals.

Silencer maintenance

RESETTING MAINTENANCE PARAMETERS AFTER SILENCER MAINTENANCE OPERATION

When the maintenance of an element has been done, it is necessary to reset its meter to stop the warning and reset the functional delay of this element.

Setting / Observations	Action / Observations	Display / Observations
Accessing the parameter programming : The programming made at the factory is protected by an access code which disables the entry of new parameters	Press the key	
	Press the key until the code is obtained	
	Valid the code with the key	
Access in the "MAINTENANCE" menu	Press the key repeatedly to access to	
	MAINTENANCE MENU Valid with the key	
Access to chosen parameter menu.	Press the key repeatedly to access the chosen MENU	
	Press the key  and 	
	pressing 	
Reset the parameter.	The fresh screen appears	
	Press the key repeatedly  or 	
	to reset the delay	
	Valid with the key	
		<div style="border: 1px solid gray; padding: 5px; background-color: #f0f0f0;"> ACCESS CODE ----- CODE : 0 </div>
		<div style="border: 1px solid gray; padding: 5px; background-color: #f0f0f0;"> DEFINITION SETTING MENU MAINTENANCE MENU OPERATING TIME </div>
		<div style="border: 1px solid gray; padding: 5px; background-color: #f0f0f0;"> OVERHAUL ADP ADP LP BEARINGS INSPECT SILENCER OVERHAUL ROOTS </div>
		<div style="border: 1px solid gray; padding: 5px; background-color: #f0f0f0;"> COUNTER SET DURATION : 0 H MAXI : 17000 H MINI : 1000 H </div>

Freeing up the ADP

If, after a prolonged stop, the ADP does not restart using the function START because of sub-products deposited inside the pump, it is possible to free it up manually.

Consult the standard precautions before intervention. (See Section D 00)

• ACCESS THE DRIVING SHAFT BEARING

3 Remove the protective cover (1) and remove the O-ring by removing the three M4 x 10 CHc screws.

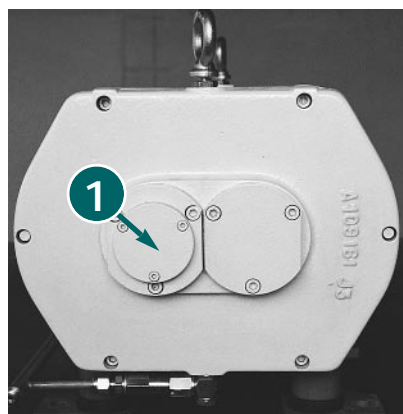

• FREEING UP BY ROTATING THE DRIVING SHAFT

21 Using the box wrench, move the driving shaft in both directions of rotation until free rotation is obtained.

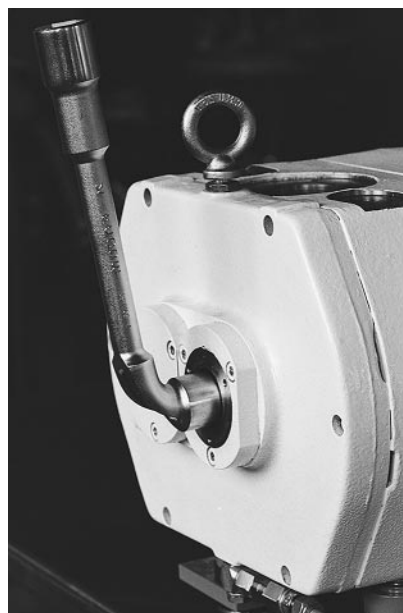

• REFIT THE PROTECTIVE COVER

3 Clean the O-ring and grease it lightly with vacuum grease. Reinstall the O-ring and the protective cover.

• RESTART THE PUMP

Restart by pressing the "START" switch on the monitor.