



On-Board IS 1000 Compressor Installation, Operation and Maintenance Manual



FOR SALES AND SERVICE PLEASE CALL:

PTB SALES T :: 626.334.0500
service@ptbsales.com
www.ptbsales.com

DATE SERVICED: _____

VIEW OUR INVENTORY

Information provided within this document is subject to change without notice, and although believed to be accurate, Brooks Automation assumes no responsibility for any errors, omissions, or inaccuracies.

AcuLigner™, Align™, AquaTran™, AutoTeach™, ATR™, AXM™, Basic Blue™, BiSymmetrik™, CenterSmart™, Cool Solutions™, Crate to Operate™, e-RMA™, e-Spares™, e-Volution™, FastRegen™, FIXLOAD™, FrogLeg™, InLigner™, InCooler™, Interface™, Jet Engine™, LowProfile™, M2 Nano™, Mini-Ion™, PASIV™, PowerPak™, PerformanceBlue™, PowerPak™, PowerTools™, QuadraFly™, Radius™, Radiant™, Radiant Express™, Reliance™, Reliance ATR™, RetroEase™, SCARA™, SmartPM™, SPOTLevel™, Synetics™, The New Pathway to Productivity™, Time Optimized Trajectory™, Time Optimal Trajectory™, Time Optimized Path™, TopCooler™, TopLigner™, Ultimate Blue™, VAC-407™, VacuTran™, Vacuum Quality Monitor™, VQM™, Vacuum Quality Index™, VQI™, and the Brooks logo are trademarks of Brooks Automation, Inc.

AcuTran®, AquaTrap®, Conductron®, Convector®, the Cool Solutions logo, Cryodyne®, Cryotiger®, Cryo-Torr®, Fusion®, GOLDLink®, Granville-Phillips®, Guardian®, GUTS®, Helix®, Jet®, Leapfrog®, MagnaTran®, MapTrak®, Marathon®, Marathon 2®, Marathon Express®, Micro-Ion®, MiniConvector®, On-Board®, Polycold®, Razor®, Simplicity Solutions®, the Simplicity Solutions logo, Stabil-Ion®, TrueBlue®, TurboPlus®, Vision®, Zaris®, and the Brooks Automation logo are registered U.S. trademarks of Brooks Automation, Inc.

All other trademarks are properties of their respective owners.

© 2013 Brooks Automation, Inc. All Rights Reserved. The information included in this manual is Proprietary Information of Brooks Automation and is provided for the use of Brooks Automation customers only and cannot be used for distribution, reproduction, or sale without the express written permission of Brooks Automation. This information may be incorporated into the user's documentation, however any changes made by the user to this information is the responsibility of the user.



For Technical Support:

Location	GUTS® Contact Number
North America	+1-800-FOR-GUTS (1-800-367-4887) +1-978-262-2900
Europe	+49-1804-CALL-GUTS (+49-1804-2255-4887)
Japan	+81-45-477-5980
China	+86-21-5131-7066
Taiwan	+886-3-5525225
Korea	+82-31-288-2500
Singapore	+65-6464-1481

Visit us online: www.brooks.com

January 11, 2013 Part Num 8040597 Revision A

This technology is subject to United States export Administration Regulations and authorized to the destination only; diversion contrary to U.S. law is prohibited.

Printed in the U.S.A.

Contents

Introduction

Helium Refrigeration System.....	1-3
Specifications	1-5
Component Description	1-10
On-Board IS Cryopump Connections.....	1-14

Safety

Introduction	2-2
Signal Word Descriptions.....	2-3
Safety Shape Descriptions.....	2-4
References	2-4

Unpacking and Inspection

Shipping Carton Inspection	3-2
Removal from Shipping Carton.....	3-2
Compressor Inspection	3-4

Installation

Introduction	4-2
Cooling Water Line Connections.....	4-3
Helium Flex Line Connections.....	4-5

Compressor EMO Remote Connections 4-7
 EMO Remote Operation and EMO Box Installation 4-9
 Power Cable Connections 4-10
 Phase Check 4-13
 Compressor Logic Module Connections 4-14
 Protection from Seismic Events 4-17

Operation

Adjusting System Helium Pressure 5-2
 OFF Condition Helium System Pressure Verification 5-3
 Compressor Operation 5-4
 Replacement of Helium Circuit Components 5-6

Maintenance

Scheduled Maintenance 6-2
 Adjusting System Helium Pressure 6-5

Appendices

Appendix A: Customer Brooks Automation Technical Support Information. . . 7-2
 Appendix B: Troubleshooting Procedures 7-3
 Appendix C: Diagrams 7-9

Tables

1-1	Compressor Weight.....	1-6
2-1	Safety Signal Words.....	2-3
5-1	On-Board IS 1000 Compressor Helium Charge (OFF Condition)	5-3
6-1	Suggested Maintenance Equipment	6-2
7-1	Compressor Troubleshooting Procedures	7-4

This Page Intentionally Left Blank

Figures

1-1	On-Board IS 1000 Compressor	1-4
1-2	On-Board IS 1000 Compressor Dimensions	1-5
1-3	Water Flow Rate Versus Pressure Drop	1-8
1-4	Cooling Water Flow Versus Inlet Temperature (High Voltage Configuration) 1-9	
1-5	On-Board IS 1000 Compressor Front Panel Component Locations	1-10
1-6	On-Board IS 1000 Compressor Rear Panel Component Locations	1-11
3-1	Using the Shipping Carton Ramp	3-3
4-1	On-Board IS 1000 Compressor Installation Flowchart	4-2
4-2	Connecting/Disconnecting Helium Flex Line Self Sealing Couplings ..	4-6
4-3	EMO Remote Connections	4-7
4-4	On-Board IS 1000 Compressor Connection Covers	4-11
4-5	Circuit Breaker Area	4-11
4-6	Single On-Board IS 1000 Compressor - Multiple On-Board IS Cryopump Con- figuration	4-15
4-7	Multiple On-Board IS 1000 Compressor - Multiple On-Board IS Cryopump Configuration	4-16
4-8	Removing the Caster Hex Bolts from the Compressor Bottom	4-18
4-9	Seismic Mount Mounting Points	4-19
6-1	Disconnecting Self Sealing Couplings	6-3
6-2	Adsorber Location within the On-Board IS 1000 Compressor (Rear Panel Removed)	6-4
6-3	Helium Pressure Control Components	6-5
7-1	On-Board IS 1000 Compressor Front Panel Indicators	7-4
7-2	On-Board IS 1000 Compressor Helium Flow Diagram	7-10
7-3	On-Board IS 1000 Compressor Electrical Schematic (8135399P002, High Voltage)	7-10
7-4	On-Board IS 1000 Compressor Electrical Schematic (8135399P001, Low Voltage)	7-11

This Page Intentionally Left Blank

1

Introduction

Overview

This manual provides the information required to install, operate, and maintain the On-Board IS 1000 Compressor.

NOTE: *All personnel with installation, operation, and maintenance responsibilities should become familiar with the contents of both the On-Board IS 1000 Compressor Installation, Operation, Maintenance, and appropriate cryopump manuals to ensure safe, high quality, and reliable system performance.*

NOTE: *There are no user serviceable components in the On-Board IS 1000 Compressor except for the adsorber. Refer to [Maintenance on page 6-1](#) for instructions on adsorber replacement.*

Refer to [Appendix A: Customer Brooks Automation Technical Support Information on page 7-2](#) and contact your local Customer Support Center for information on connecting On-Board IS 1000 Compressors to a manifold with other Brooks Automation compressors.

Chapter Contents

Helium Refrigeration System.....	1-3
Specifications	1-5
Dimensions	1-5
Weight	1-6
Electrical	1-6
Cooling Water.....	1-7
General.....	1-8
Component Description	1-10
Front Panel Components	1-10

Rear Panel Components	1-11
System Circuit Breaker	1-11
Control Circuit Breaker	1-12
Power ON Indicator	1-12
Gas Charge Flared Fitting	1-12
Compressor Logic Module	1-12
Helium Pressure Gauge	1-12
Power Inlet	1-12
On-Board IS Cryopump Connections	1-14
Return Gas Coupling	1-12
Cooling Water IN	1-13
Cooling Water OUT	1-13
EMO Remote Connector	1-13
Supply Gas Coupling	1-13

Helium Refrigeration System

The operation of Brooks Automation cryopumps is based upon a closed loop helium expansion cycle. The *system* is made up of two major components: the cryopump, which contains the cold head, and the helium Compressor which compresses the helium gas.

Refrigeration is produced in the cryopump cold head through periodic expansion of high pressure helium in a regenerative process. The high pressure helium is provided by the Compressor. Low pressure helium returning from the cold head is compressed into the necessary high pressure to be returned to the cold head. The energy required to compress the helium is rejected as heat through the cooling water.

High pressure room temperature helium is transferred to the cold head through the supply lines. After expansion, low pressure helium is returned to the Compressor (at or near room temperature) to repeat the cycle in a closed loop fashion. Large separation distances can be accommodated between the Compressor and the cryopump.

In the Compressor, helium is compressed using a highly reliable oil lubricated commercial Compressor. Helium purification takes place via several stages of oil removal. The final stage of purification is performed with a replaceable adsorber cartridge. In order to maintain peak efficiency, the adsorber must be replaced every three years. The On-Board IS 1000 Compressor is shown in [Figure 1-1](#).

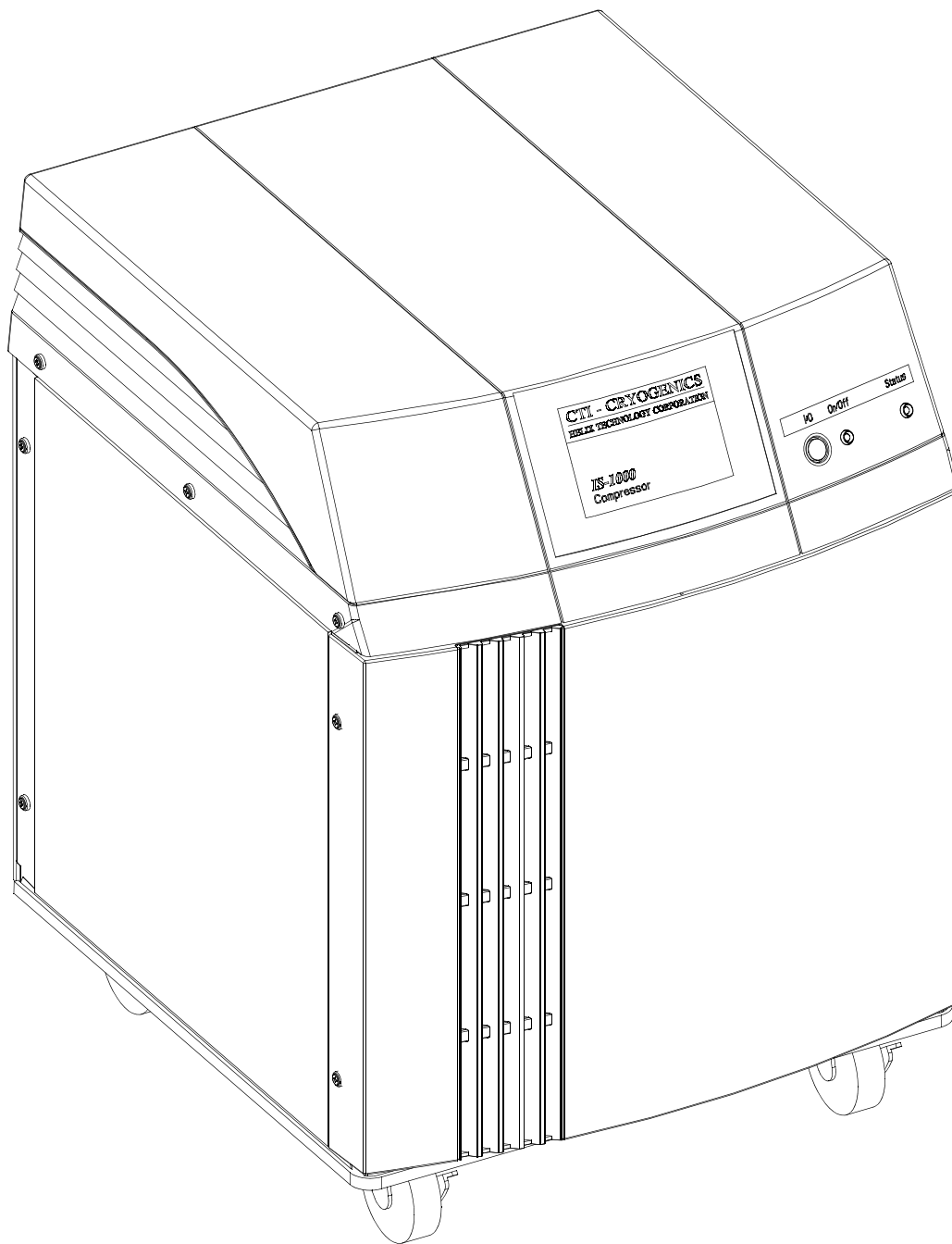

Figure 1-1: On-Board IS 1000 Compressor

Specifications

Dimensions

The dimensions of the Compressor are shown in [Figure 1-2](#).

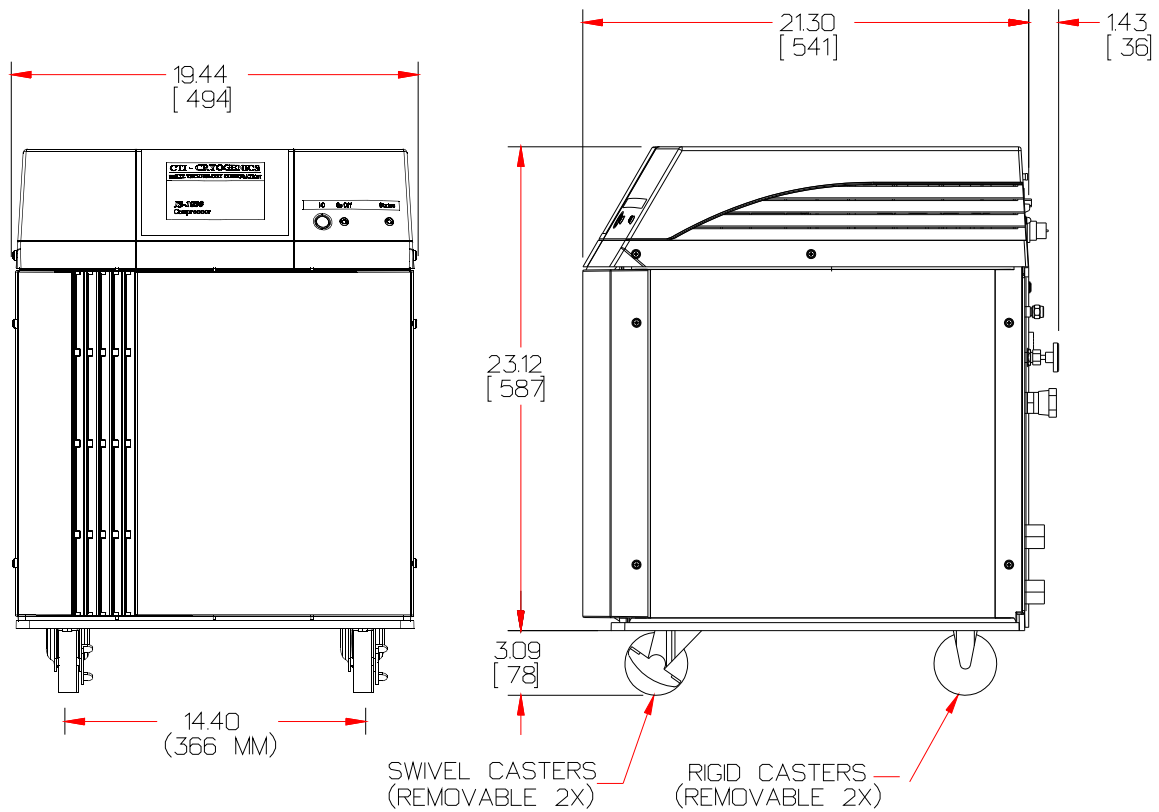



Figure 1-2: On-Board IS 1000 Compressor Dimensions

	<p style="text-align: center;">CAUTION</p> <p style="text-align: center;">Compressor Damage</p> <p>To avoid damaging the compressor unit, do not place a weight greater than 75 lbs. (34Kg) on top of the compressor.</p>
---	---

Weight

The weight of the Compressor is listed in [Table 1-1](#).

Table 1-1: Compressor Weight

Compressor Type	Weight lbs./kg
IS 1000 Low Volt	210/95
IS 1000 High Volt	222/102

NOTE: *It is recommended that proper heavy-lifting equipment such as a pallet jack be used, if the compressor needs to be lifted.*

Electrical

The electrical specifications of the Compressor are listed in [Table 1-2](#).

Table 1-2: Compressor Electrical Input Specifications

Parameter	Low Volt	High Volt
Operating Voltage	180 - 253 VAC	342 - 528 VAC
Line Frequency	50/60 Hz	50/60 Hz
Phase	3	3
Nominal Input Power	5.8 KW	5.8 KW
Rated Full Load/Locked Rotor Current	19/85	10/42
Minimum Electrical Service	30 Amps	20 Amps

NOTE: *The main disconnect with lock out/tag out function must be positioned immediately adjacent to the compressor.*

Cooling Water

The water used to cool the Compressor must meet the specifications shown in [Table 1-3](#) for proper system operation.

Table 1-3: Cooling Water Specifications

Parameter	Value
Maximum Inlet Temperature	90°F (32°C)
Minimum Inlet Temperature	50°F (10°C)
Flow Rate ¹	2.75 ±1.25 gpm (10.4 ± 4.7 lpm)
Pressure Drop (inlet-to-outlet)	See Figure 1-3 on page 1-8
Maximum Inlet Pressure	100 psi (6.9 bars)
Alkalinity	6.0 - 8.0 pH
Calcium Carbonate	< 75 ppm
Deionized Water Usage	Do not use above 100,000ohm-cm resistivity
<p>NOTE: <i>Water conditioning may be required for applications not meeting these requirements.</i></p> <p>NOTE: ¹<i>For 60 Hz operation with voltage less than 375V, refer to Figure 1-4 on page 1-9 for additional water flow requirements.</i></p>	

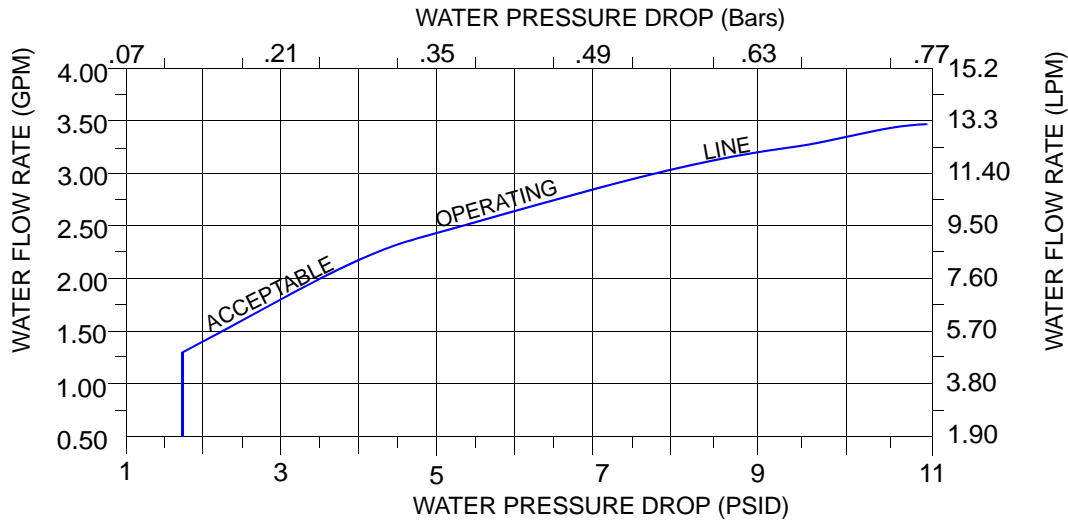

NOTE: *Figure 1-3 defines the water flow rate through the Compressor as a function of the pressure drop from water inlet to water outlet. You must provide the correct pressure drop in your water supply system to ensure that the water flow condition meets the requirements specified in [Table 1-3 on page 1-7](#).*

Figure 1-3: Water Flow Rate Versus Pressure Drop

General

The information in [Table 1-4](#) provides general Compressor operating specifications. See [Figure 1-4 on page 1-9](#) for specifications of cooling water flow versus inlet temperature for the high voltage IS 1000 configuration.

Table 1-4: General Compressor Operating Specifications

Specification	Values
Part Number	8135921G002, 8135926G002
Input Power Cable (Customer Supplied)	600 VAC 10 Gauge, 3 conductor wire with ground Must conform to local electrical codes
Nominal Helium Pressure	Refer to Figure 3-1 on page 3-3
Ambient Operating Temperature Range	50 - 100° F (10 - 38° C)

Table 1-4: General Compressor Operating Specifications (Continued)

Specification	Values
Gas Supply Connector Gas Return Connector EMO Remote Control Receptacle	1/2 in. Aeroquip self-sealing coupling, male thread. 1/2 in. Aeroquip self-sealing coupling, female thread. Mates with P5 connector part number MS3106A*
Adsorber Service Schedule	3 Years
* Supplied by Brooks Automation	

NOTE: The On-Board IS 1000 Compressor is designed for continuous operation and should remain ON when the cryopumps are in a regeneration cycle.

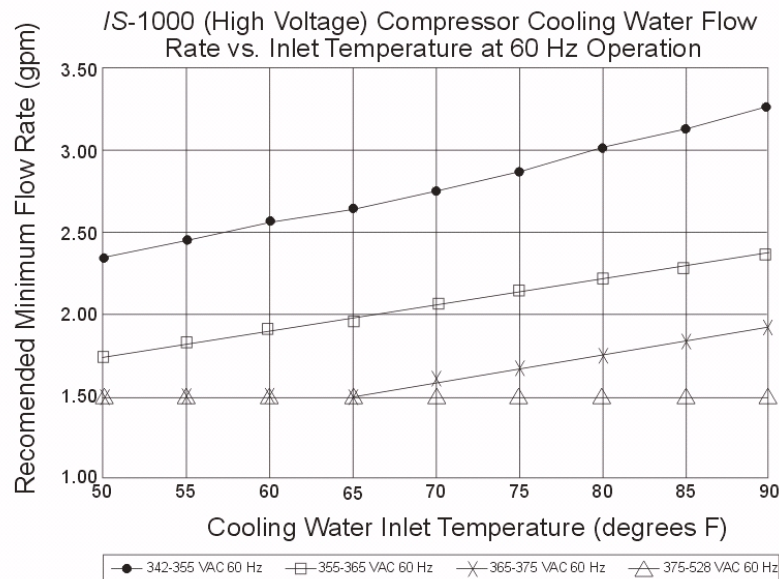

Figure 1-4: Cooling Water Flow Versus Inlet Temperature (High Voltage Configuration)

Component Description

Front Panel Components

The front panel components of the On-Board IS 1000 Compressor are shown in [Figure 1-4 on page 1-9](#) and described in the following paragraphs.

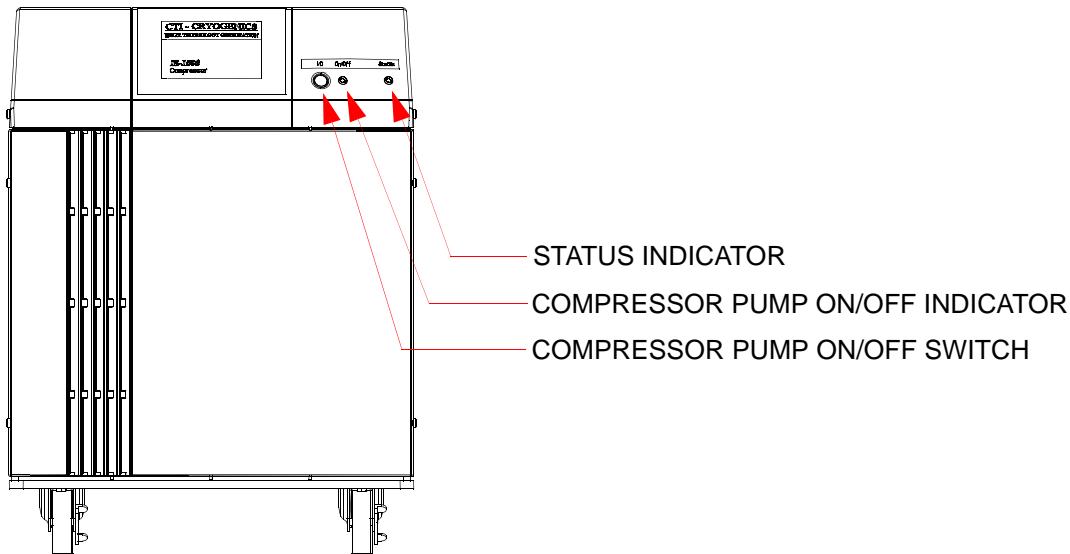

Figure 1-5: On-Board IS 1000 Compressor Front Panel Component Locations

Compressor Pump ON/OFF Switch

The Compressor Pump ON/OFF Switch is a push button switch that turns the Compressor Pump ON or OFF.

Compressor Pump ON/OFF Indicator

The Compressor Pump ON/OFF Indicator is green when the compressor pump is operating, and OFF when the compressor pump is OFF.

Status Indicator

Status Indicator is red when a fault condition exists within the On-Board IS 1000 Compressor. Refer to [Appendix B: Troubleshooting Procedures on page 7-3](#) for more information.

Rear Panel Components

The components of the On-Board IS 1000 Compressor that are accessible from the rear panel are shown in [Figure 1-6](#) and described in the following paragraphs.

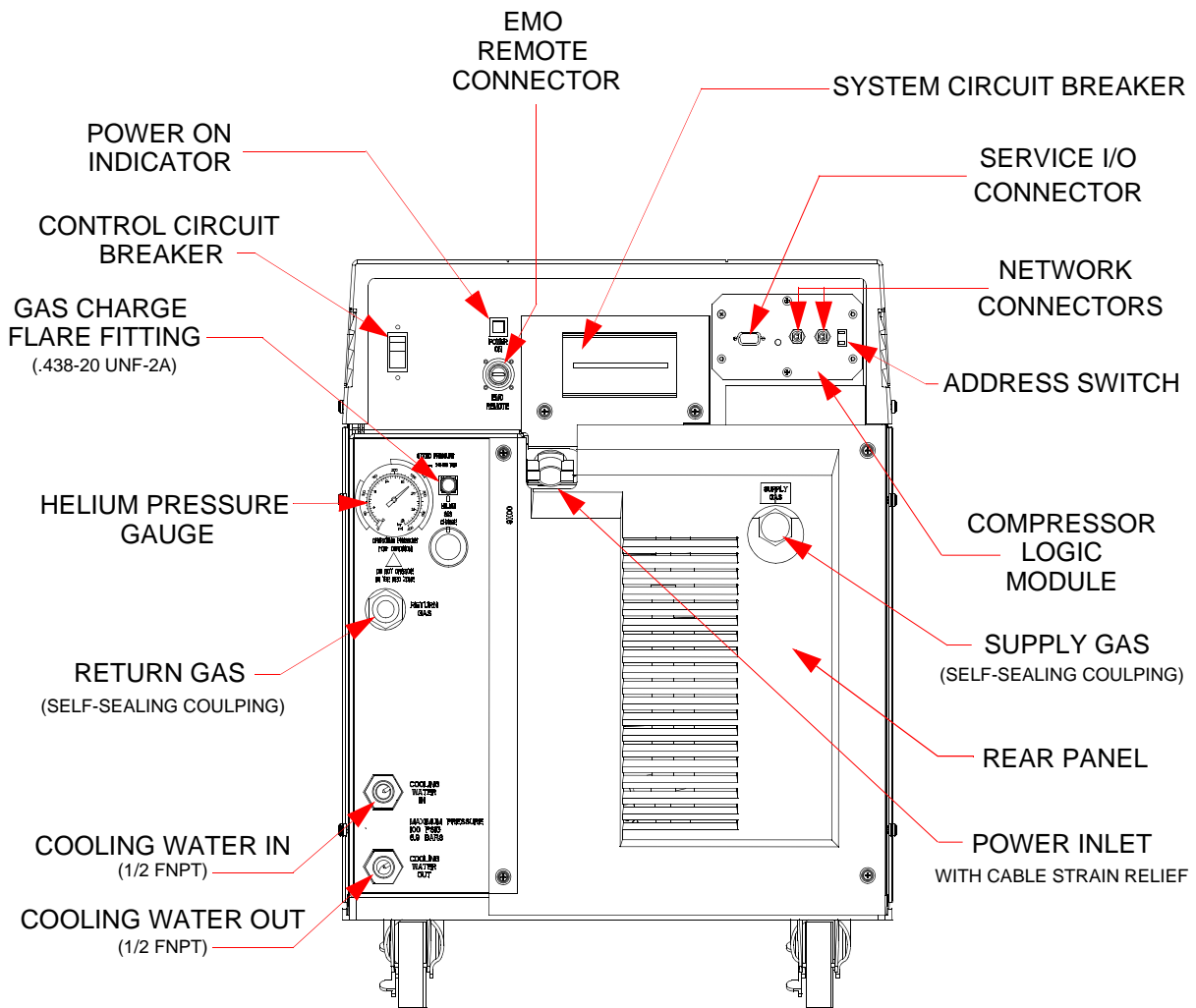

Figure 1-6: On-Board IS 1000 Compressor Rear Panel Component Locations

System Circuit Breaker

The System Circuit Breaker protects main input power to the Compressor pump and module. The circuit breaker positions are labeled ON (1), which is in the UP position, and OFF (0), which is in the DOWN position.

NOTE: *The phase monitor within the Compressor will cause the system circuit breaker to open when input power phases are incorrect.*

Control Circuit Breaker

The Control Circuit Breaker provides current overload protection for all internal components of the Compressor except the Compressor motor. The Compressor motor is protected by a separate overload protector. The Control Circuit Breaker opens automatically and must be reset manually.

Power ON Indicator

The Power On Indicator illuminates when the system and control circuit breakers are placed in the ON position and the Remote connector is closed.

Gas Charge Flared Fitting

The Gas Charge Flared Fitting is used to connect a 99.999% pure helium supply to the Compressor when helium charging is required. The fitting has SAE 45° flare.

NOTE: Refer to [Maintenance on page 6-1](#) for information on adding helium to the Compressor.

Compressor Logic Module

The Compressor Logic Module monitors the status of the compressor and communicates with the On-Board IS Controller via channel C of the Intercomponent Network.

Helium Pressure Gauge

The Helium Pressure Gauge indicates system helium charge pressure (OFF condition) when the Compressor and cryopumps are OFF and Compressor suction or inlet pressure when the Compressor is ON. Refer to [Table 5-1 on page 5-3](#) for the appropriate helium charge pressure (OFF condition).

Power Inlet

The Power Inlet is used to connect your power cable to the Compressor. Refer to [Installation on page 4-1](#) for information on power cable installation.

Return Gas Coupling

The Return Gas Coupling returns the helium, which has been cycled through the cryopump, back to the Compressor. Refer to [Helium Refrigeration System on page 1-3](#) within this section for more information.

Cooling Water IN

The Cooling Water IN connector provides water to the Compressor from your facility to cool the Compressor during operation. The connector thread size is a 1/2 in. female pipe thread. The water must meet the specifications outlined in [Table 1-3 on page 1-7](#). Refer to [Installation on page 4-1](#) for more information on cooling water connections.

Cooling Water OUT

The Cooling Water OUT connector returns the water that has been used to cool the Compressor to your facility. The connector thread size is a 1/2 in. female pipe thread. Refer to [Installation on page 4-1](#) for more information on cooling water connections.

EMO Remote Connector

The EMO Remote Connector is a two-pin connector. Refer to [Installation on page 4-1](#) for more information on Compressor remote connections.

NOTE: *The Compressor is shipped with a mating plug which must remain installed in the EMO Remote Connector to ensure Compressor operation when the remote EMO feature is not being used.*

Supply Gas Coupling

The Supply Gas Coupling provides a connection for high pressure compressed helium to the cryopump cold head. Refer to [Helium Refrigeration System on page 1-3](#) within this section for more information.

On-Board IS Cryopump Connections

The On-Board IS 1000 Compressor supports the connection of multiple On-Board IS Cryopumps as shown in [Installation on page 4-1](#).

NOTE: *Refer to [Appendix A: Customer Brooks Automation Technical Support Information on page 7-2](#) and contact your local Brooks Automation Customer Support Center if you need more information on specific compressor/pump applications.*

2

Safety

Overview

This section describes safety conventions for the Brooks Automation Product. All personnel involved in the operation or maintenance of the product must be familiar with the safety precautions outlined in this section.

NOTE: *These safety recommendations are basic guidelines. If the facility where the Product is installed has additional safety guidelines they should be followed as well, along with the applicable national and international safety codes.*

Chapter Contents

Introduction	2-2
Signal Word Descriptions.....	2-3
Safety Shape Descriptions.....	2-4
References	2-4

Introduction

Follow all safety precautions during installation, normal operation, and when servicing BROOKS-Cryogenics products.



This chapter explains the safety conventions used throughout this manual. BROOKS-Cryogenics uses a specific format for cautions and warnings, which includes standard signal words and safety shapes.

See also the *Customer Support* appendix or call your local Customer Support Center for assistance.

Signal Word Descriptions

All cautions and warnings contain signal words, which call attention to safety messages and designate the degree of hazard seriousness. The following table shows the signal words and their meanings that may be used in this document.



Table 2-1: Safety Signal Words

Term	Example	Definition
CAUTION		A signal word that indicates a situation or unsafe practice, which if not avoided may result in equipment damage . A CAUTION is highlighted in yellow.
CAUTION		A signal word accompanied by a safety shape that indicates a potentially hazardous situation or unsafe practice. If not avoided, the action may result in minor or moderate personal injury or equipment damage . A CAUTION is highlighted in yellow.
WARNING		A signal word accompanied by a safety shape that indicates a potentially hazardous situation. If not avoided, the action may result in serious injury or death . A WARNING is highlighted in orange.

Safety Shape Descriptions

All cautions and warnings contain safety shapes, which have specific safety meanings. The following table shows some of the safety shapes used in this document and their meanings.

Table 2-2: Safety Shapes

Example	Term	Shape Definition
	General Warning	Indicates a general hazard. Details about this hazard appear in the safety notice explanation.
	High Voltage	Indicates a high voltage hazard.
	Hot Surface	Indicates a surface is hot enough to cause discomfort or a burn.

References

For more information about safety standards, see the following documents:

- ISO 7010: 2003(E), Graphic symbols - Safety colours and safety signs - Safety signs used in workplaces and public areas
- ISO 3864-1: 2002(E), Graphic symbols - Safety colours and safety signs - Part 1: Design principles for safety signs in workplaces and public areas

3 Unpacking and Inspection

Overview

This chapter details the specifications of the unpacking and inspection of the Brooks Automation product.

The On-Board *IS* 1000 Compressor is shipped in a shipping carton incorporating a ramp system which makes removing the Compressor from the carton safe and easy.

Chapter Contents

Shipping Carton Inspection	3-2
Removal from Shipping Carton.....	3-2
Using the Ramp	3-2
Compressor Inspection	3-4
Compressor.....	3-4
Helium Static Pressure Verification	3-4
Shipping Carton Contents	3-4

Shipping Carton Inspection

Inspect the exterior of the shipping carton for visible signs of damage before opening the shipping carton. Report any damage to the shipping company at once.

Removal from Shipping Carton

There are two methods of removing the On-Board IS 1000 Compressor from the shipping carton: using the ramp within the carton, or using a lifting device.

Using the Ramp

1. Cut the two straps on the exterior of the shipping pallet.
2. Lift the cardboard carton straight up and remove it from the pallet.
3. Cut the tape which holds the ramp in the vertical position.
4. Swing the ramp down until the end touches the floor as shown in [Figure 3-1 on page 3-3](#).
5. Remove any excess shipping material from around the Compressor.

	<p style="text-align: center;">WARNING</p> <p style="text-align: center;">Personal Injury</p> <p>To avoid personal injury or equipment damage, maintain control of the compressor as it rolls down the ramp.</p>
---	--

6. Unlock the swivel casters as shown in [Figure 3-1 on page 3-3](#).
7. Carefully roll the Compressor down the ramp and onto the floor as shown in [Figure 3-1 on page 3-3](#).

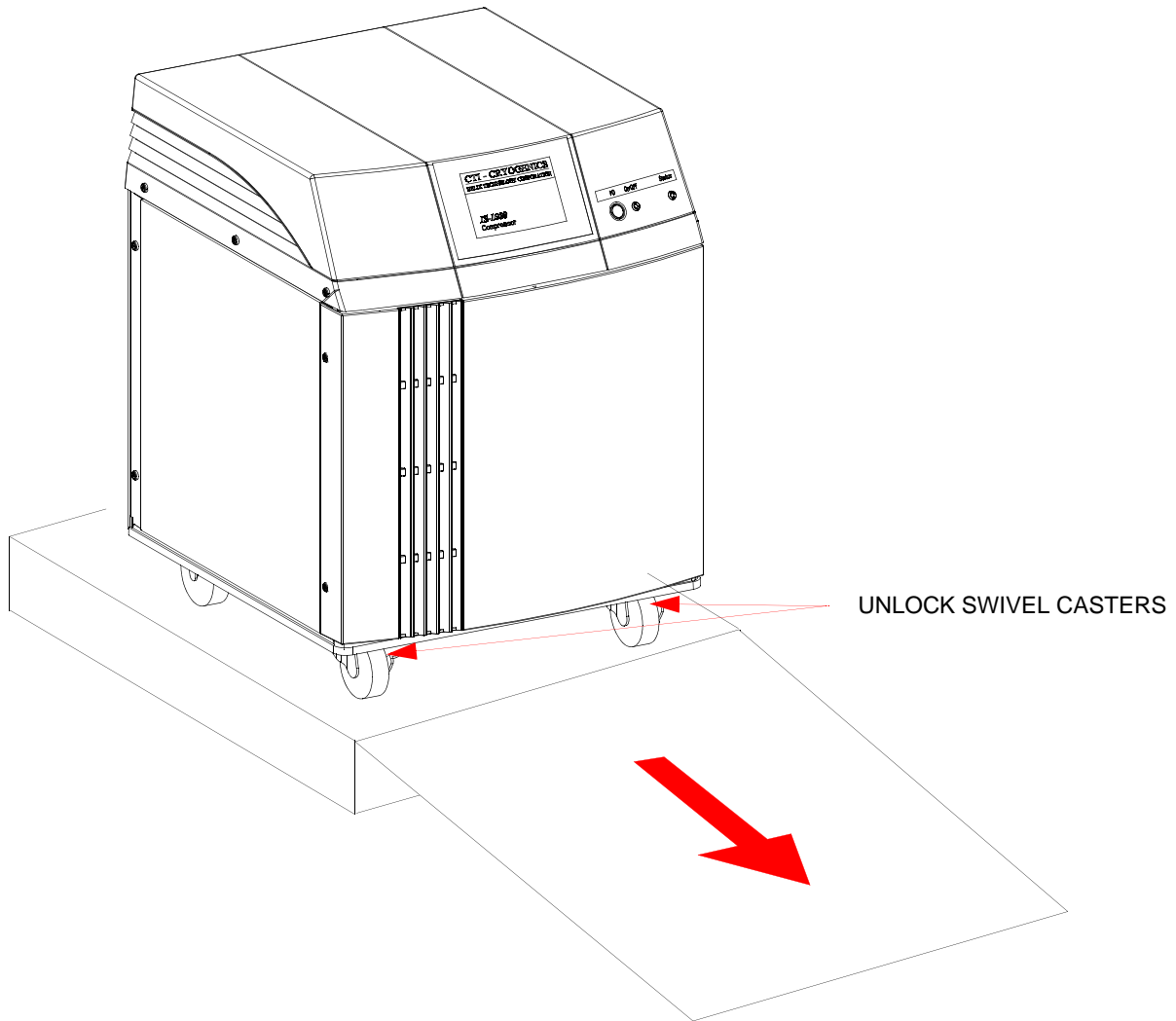

Figure 3-1: Using the Shipping Carton Ramp

Compressor Inspection

Inspect the Compressor for visible signs of damage as indicated in the following paragraphs.

Compressor

Inspect the exterior of the Compressor for visible signs of damage, evidence of an oil leak, and check the Helium Pressure Gauge for proper helium pressure. Report any damage to the shipping company at once.

Helium Static Pressure Verification

Refer to [Operation on page 5-1](#) for more information on the static helium charge pressure of the On-Board IS 1000 Compressor.

Shipping Carton Contents

The shipping carton should contain the following items:

- Compressor
- Two barbed fittings for flexible water lines
- Installation, Operation, and Maintenance manual

4

Installation

Overview

This chapter provides complete installation procedures for the Brooks Automation Product including: unpacking, assembly, facilities connections, initial setup, and initial check-out.

This section provides you with the information required to install the On-Board *IS* 1000 Compressor and connect it to multiple On-Board *IS* Cryopump configurations.

Chapter Contents

Introduction	4-2
Cooling Water Line Connections.....	4-3
Hard Water Lines.....	4-3
Flexible Water Lines	4-3
Helium Flex Line Connections.....	4-5
Disconnecting.....	4-6
Compressor EMO Remote Connections.....	4-7
EMO Remote Operation and EMO Box Installation.....	4-9
Power Cable Connections.....	4-10
Phase Check	4-13
Compressor Logic Module Connections	4-14
Protection from Seismic Events	4-17
Before You Start	4-17
Attaching a Seismic Mount to an On-Board IS 1000 Compressor	4-17

Introduction

Figure 4-1 highlights the major tasks for Compressor installation and refers to the appropriate installation procedures within this section.

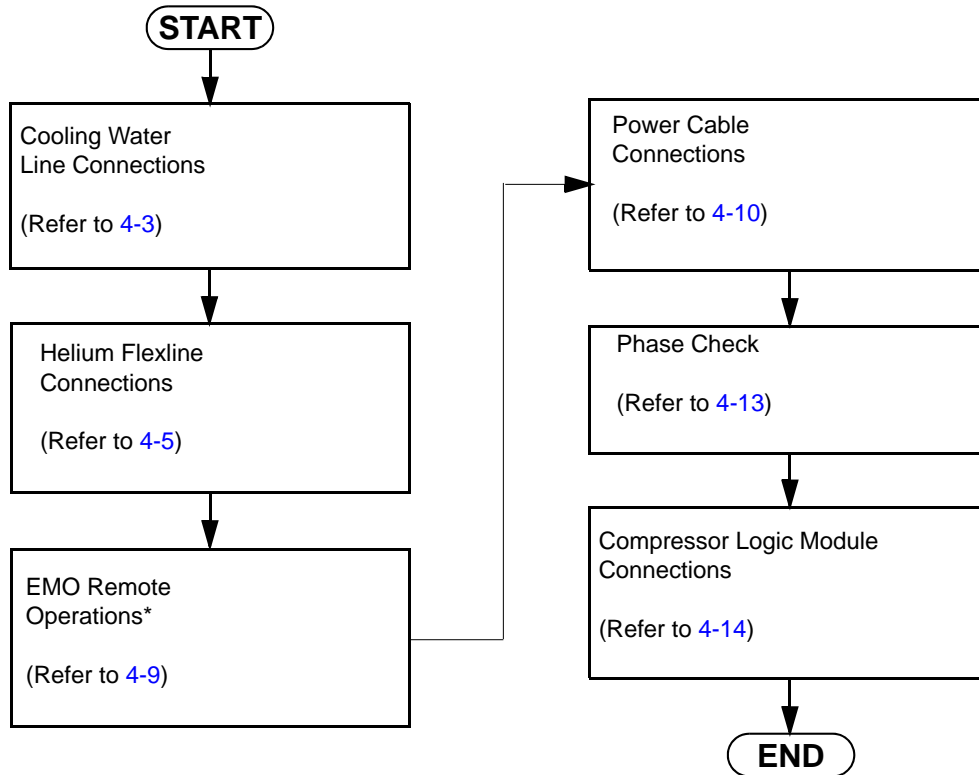

* ONLY REQUIRED FOR REMOTE EMO COMPRESSOR

Figure 4-1: On-Board IS 1000 Compressor Installation Flowchart

Cooling Water Line Connections

NOTE: *The water used for cooling the Compressor must meet the specifications outlined in [Table 1-1 on page 1-6](#).*

Hard Water Lines

1. Apply a light coating of standard plumbing thread sealant to the hard line pipe threads.
2. Install the Supply hard line into the INPUT connection on the rear panel of the Compressor. Tighten the fitting by hand.
3. Install the Return hard line into the OUTPUT connection on the rear panel of the Compressor. Tighten the fitting by hand.

	CAUTION
	Connector Thread Damage To avoid damaging the input and output connector threads, do not overtighten the ferrules.

4. Using a wrench, tighten the fittings.
5. Allow water to flow and check for leaks at the rear of the Compressor.

Flexible Water Lines

1. Apply a light coating of standard plumbing thread sealant to the barbed fitting threads.
2. Install the barbed fittings into the INPUT and OUTPUT connections on the rear panel of the Compressor.

	CAUTION
	Connector Thread Damage To avoid damaging the input and output connector threads, do not overtighten the barbed fittings.

3. Using a wrench, tighten the barbed fittings.

4. Connect the Supply flexible water line to the INPUT barbed fitting and secure with a hose clamp.
5. Connect the Return flexible water line to the OUTPUT barbed fitting and secure with a hose clamp.
6. Allow water to flow and check for leaks at the rear of the Compressor.

Helium Flex Line Connections

	<p style="text-align: center;">CAUTION</p> <p style="text-align: center;">Equipment Damage</p> <p>To avoid damaging equipment from excessive or insufficient pressure, do not connect the On-Board IS Cryopump to a manifold with other compressors, On-Board, or Cryo-Torr cryopumps.</p>
---	--

The use of several On-Board IS 1000 Compressors on a single manifold feeding a common supply header and a common return header requires special precautions. Contact Brooks Automation for a review of the intended installation and for specific technical instructions.

	<p style="text-align: center;">CAUTION</p> <p style="text-align: center;">Equipment Damage</p> <p>To avoid damaging the connector, O-ring seals, or causing a helium circuit leak, connect and disconnect the helium flex lines from the On-Board IS 1000 Compressor using the following procedure and as shown in Figure 4-2 on page 4-6.</p>
---	--

The number of On-Board IS Cryopumps connected to an On-Board IS 1000 Compressor will vary based upon the On-Board IS Cryopump models used. Refer to [Appendix A: Customer Brooks Automation Technical Support Information on page 7-2](#) for information about specific compressor/pump applications.

Connecting

1. Remove all dust plugs and caps from the Gas Supply and Return lines, and the Compressor and cryopump Supply and Return connectors. Check for the presence of a flat gasket in the male connector, and no gasket in the female connector.
2. Connect the Gas Return line to the GAS RETURN connector on the rear of the Compressor and then to the GAS RETURN connector on the On-Board IS Cryopump or helium manifold. Using two wrenches as shown in [Figure 4-2 on page 4-6](#), tighten the connector.

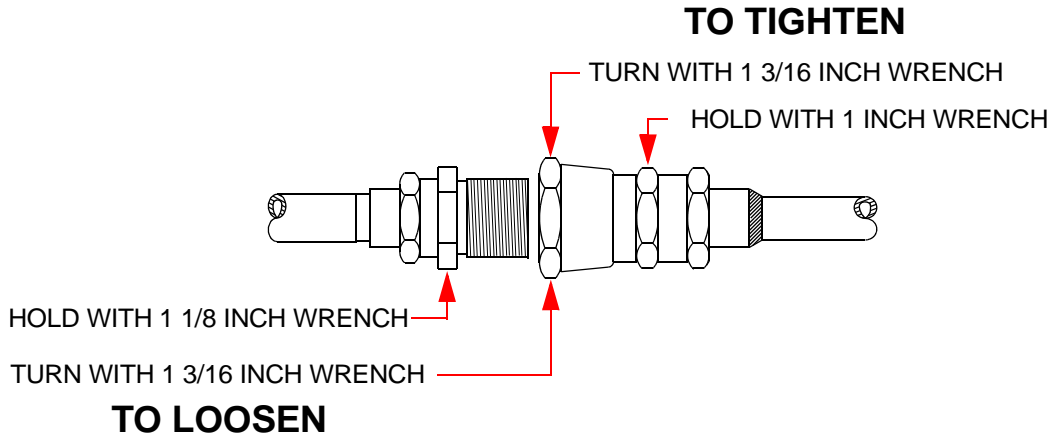

Figure 4-2: Connecting/Disconnecting Helium Flex Line Self Sealing Couplings

3. Connect the Gas Supply line to the GAS SUPPLY connector on the rear of the Compressor and then to the GAS SUPPLY connector on the On-Board IS Cryopump or helium manifold. Using two wrenches as shown in [Figure 4-2](#), tighten the connector.
4. Attach the Supply and Return line identification labels to each end of the appropriate lines.

Disconnecting

- Using two wrenches as shown in [Figure 4-2](#), disconnect the two self sealing coupling connectors quickly to minimize helium leakage.

Compressor EMO Remote Connections

NOTE: Connections to the EMO Remote Connector are only required if the Compressor uses the remote EMO box.

NOTE: The Compressor is shipped with a mating plug which must remain installed in the EMO Remote Connector to ensure Compressor operation when the EMO remote feature is not being used.

1. Remove the EMO Remote plug from the EMO REMOTE connector on the Compressor rear panel.
2. Disassemble the plug connector.
3. Unsolder the jumper wire between the pins.
4. Slide the connector components over the cable as shown in [Figure 4-3](#).

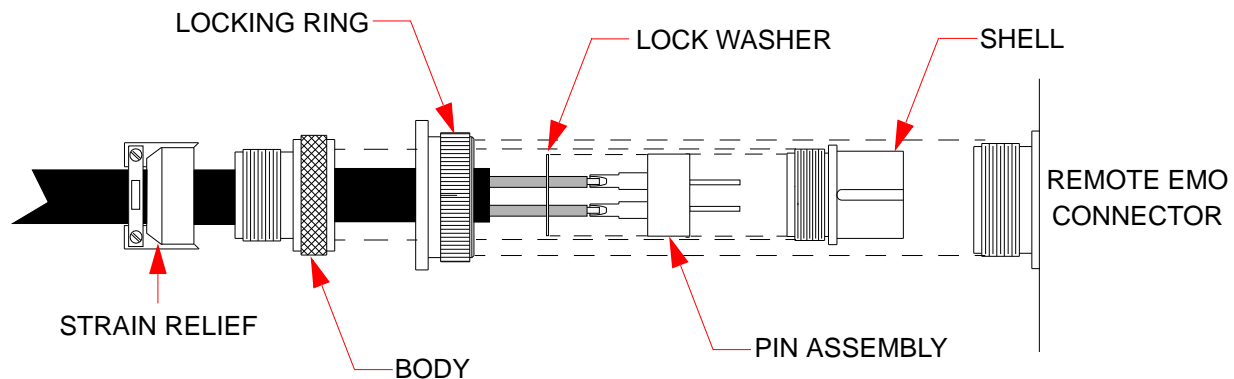

Figure 4-3: EMO Remote Connections

5. Strip the insulation from the customer supplied cable conductors and tin the conductors with solder.
6. Solder the conductors of the customer supplied cable to the plug pins as shown in [Figure 4-3](#).
7. Align the key in the connector shell with the pin assembly and install the pin assembly into the shell.
8. Install the lock washer around the pin assembly.
9. Slide the locking ring over the shell.

10. Screw the connector body into the shell threads.
11. Connect the plug to the REMOTE EMO CONNECTOR on the Compressor.
12. Connect the opposite end to the EMO box.
13. Assemble and screw the strain relief on the body and tighten the cable clamp screws.

EMO Remote Operation and EMO Box Installation

Installing the EMO box is optional. The remote EMO is mounted on the compressor with the kit provided. If the EMO box is not used, the jumper connector must be installed.

To initiate the EMO function, push the red button in. The EMO circuit immediately locks out the compressor to keep it from running. To reset power to the unit, make sure the main circuit breaker (CB1) is in the off position. Turn the EMO button clockwise and pull it out. Turn the unit back on with the circuit breakers and front power switch.

To reset the EMO, remove power by initiating these procedures:

1. Push the start button off and on.
2. Turn the control circuit breaker off then back on.
3. Turn the main circuit breaker off and on.

Power Cable Connections

The following procedure provides information for making all three phase (342-528 VAC for high voltage and 180 - 250 VAC for low voltage) electrical connections to the Compressor.

NOTE: *Input phasing sequence = counter-clockwise. Make sure that the lockout procedure (as defined by the facility) has been followed before initiating the following procedure.*

	<p style="text-align: center;">⚠ WARNING</p> <p style="text-align: center;">High Voltage</p> <p>To avoid severe injury or loss of life from high voltage electric shock, turn off all electrical power before proceeding.</p>
---	---

	<p style="text-align: center;">CAUTION</p> <p style="text-align: center;">Equipment Failure</p> <p>To avoid equipment failure, use a 10 gauge, 3 conductor cable with ground rating at 600 VAC for the Compressor</p>
--	---

1. Cut a 10 AWG (6.00 mm²), 3 conductor cable with ground to an appropriate length.
2. Strip the cable jacket back 4 in. (101.6 mm).
3. Strip the insulation back 3/8 in. (9.3 mm) on each individual conductor.
4. Install a #10 ring tongue terminal on the end of each conductor using the appropriate size double crimping tool.

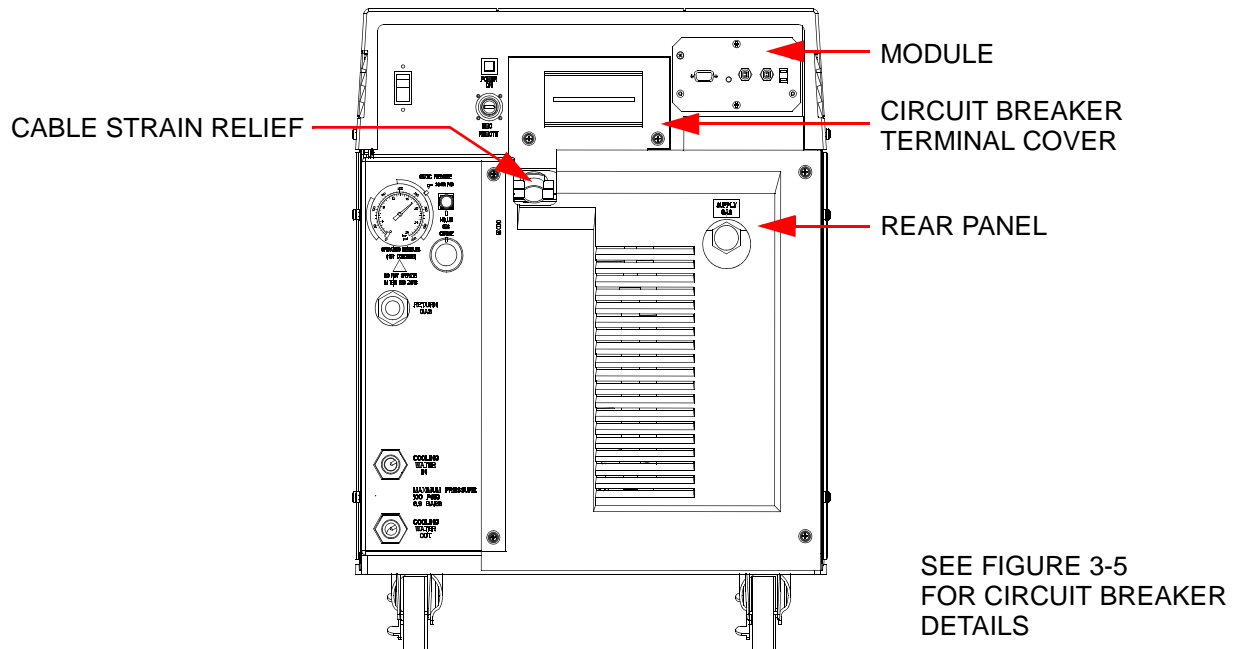

Figure 4-4: On-Board IS 1000 Compressor Connection Covers

5. Remove the rear panel and the circuit breaker terminal cover in [Figure 4-4](#).
6. Thread the conductor cable through the cable strain relief in [Figure 4-4](#).

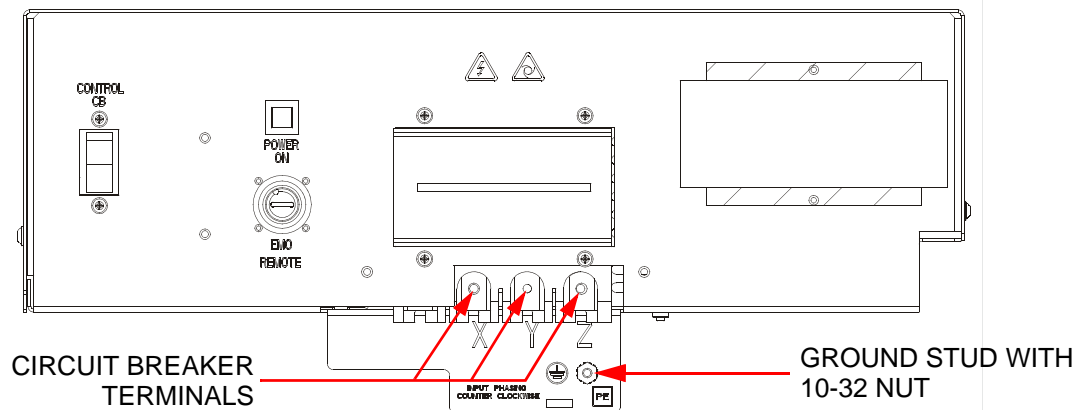

Figure 4-5: Circuit Breaker Area

7. Remove the 10-32 nut from the ground stud and install the grounding wire.
8. Replace the 10-32 nut on the ground stud and tighten to 18 in.-lbs (0.21m-kg).

NOTE: Use a slotted screwdriver that is capable of holding a screw when performing [Step 9](#) and [Step 11](#).

9. Remove the terminal screws from the circuit breaker terminals X, Y, and Z in [Figure 4-5 on page 4-11](#).

NOTE: The phase order in which the conductor terminal lugs are connected to circuit breaker terminals X, Y, and Z are determined during the Phase Check Procedure.

NOTE: For installation where one of the three phase legs is at or near ground potential, connect that leg to terminal Y on the Compressor.

10. Install the conductor terminal lugs to the circuit breaker terminals X, Y, and Z.
11. Replace and tighten the terminal screws to 12 in.-lbs (0.14m-kg).
12. Allow enough cable to stay in the circuit breaker area to prevent strain on the terminal connections, and then tighten the screws on the cable strain relief in [Figure 4-4 on page 4-11](#).
13. Install the power source end of the conductor cable according to the local electrical codes.
14. Replace the circuit breaker terminal cover from [Figure 4-4 on page 4-11](#).

Proceed with [Phase Check on page 4-13](#).

Phase Check

	<p style="text-align: center;">⚠ WARNING</p> <p style="text-align: center;">High Voltage</p> <p>To avoid severe injury or loss of life from high voltage electric shock, ensure that all steps in the previous section, Power Cable Connections on page 4-10, and the current section are followed precisely.</p>
---	---

1. Apply 208 VAC (for low voltage) or 380/480 VAC (for high voltage) power to the On-Board IS 1000 Compressor circuit.

NOTE: *The System Circuit Breaker will trip immediately during step 2 if the power phase connections are not correct.*

2. Set the System Circuit Breaker (CB1) to the ON position.
3. If the System Circuit Breaker trips, refer to step [Step 4](#). If the System Circuit Breaker does not trip, refer to step [Step 5](#).
4. If the System Circuit Breaker trips, perform the following steps:
 1. Set the System Circuit Breaker (CB1) to the OFF position.
 2. Disconnect the power cord from the power source.
 3. Remove the circuit breaker terminal cover.
 4. Reverse the wiring order of terminals X and Y.
 5. Torque the circuit breaker terminal screws to 12 in.-lbs.
 6. Install the circuit breaker terminal cover.
 7. Repeat [Step 1](#) through [Step 3](#) of this procedure.
5. Make sure the Power On indicator is illuminated.
6. Set the System Circuit Breaker (CB1) to the OFF position.
7. Install the rear panel.

Compressor Logic Module Connections

	<p style="text-align: center;">⚠ WARNING</p> <p style="text-align: center;">High Voltage</p> <p>To avoid severe injury or loss of life from high voltage electric shock, turn off the compressor power before making any connections to the rear panel.</p>
---	---

1. Refer to the *On-Board IS Controller Quick Installation Guide* (8040648 or 8040657) for information on connecting the On-Board IS 1000 Compressor to the Intercomponent Network.

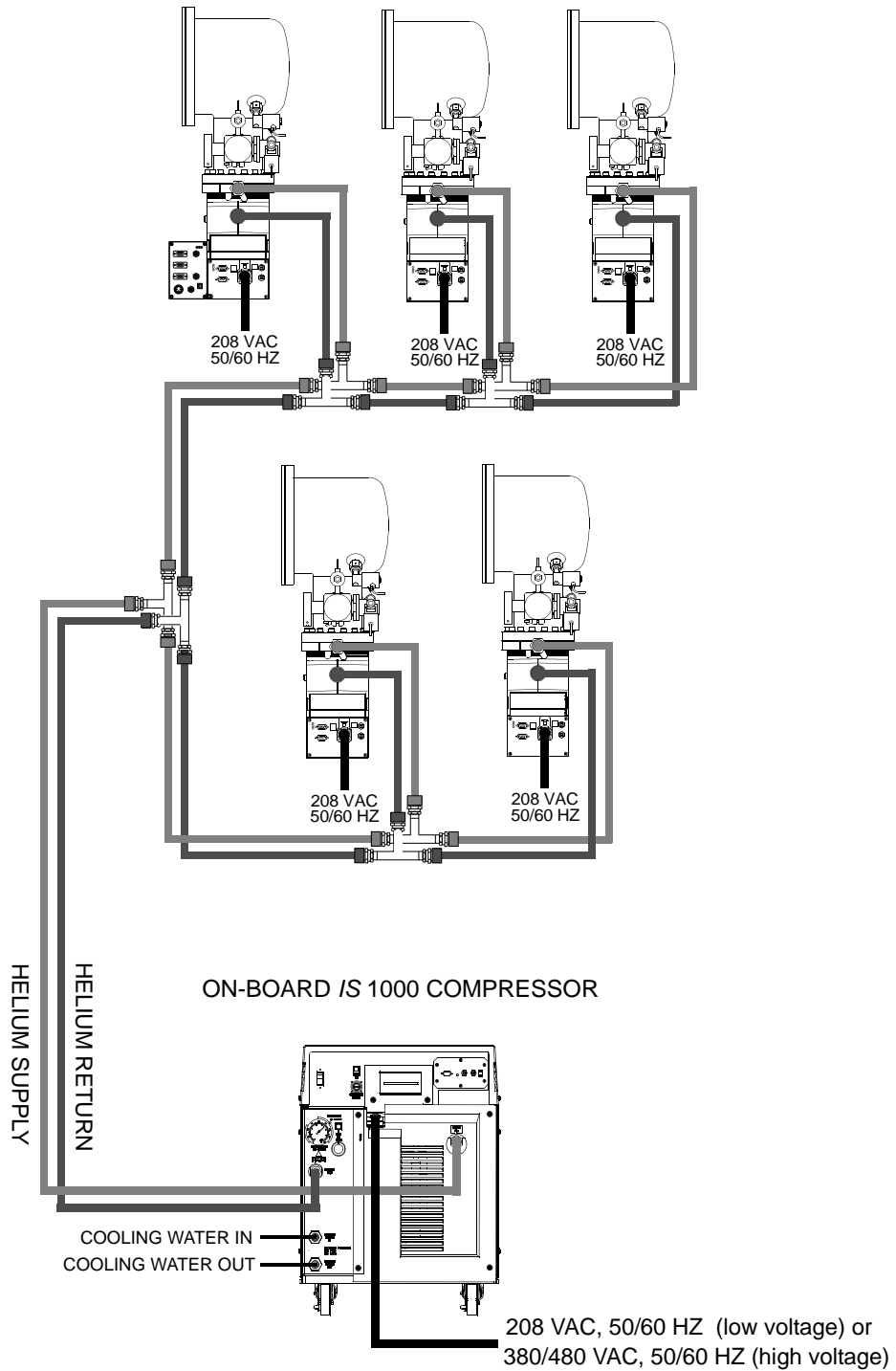

Figure 4-6: Single On-Board IS 1000 Compressor - Multiple On-Board IS Cryopump Configuration

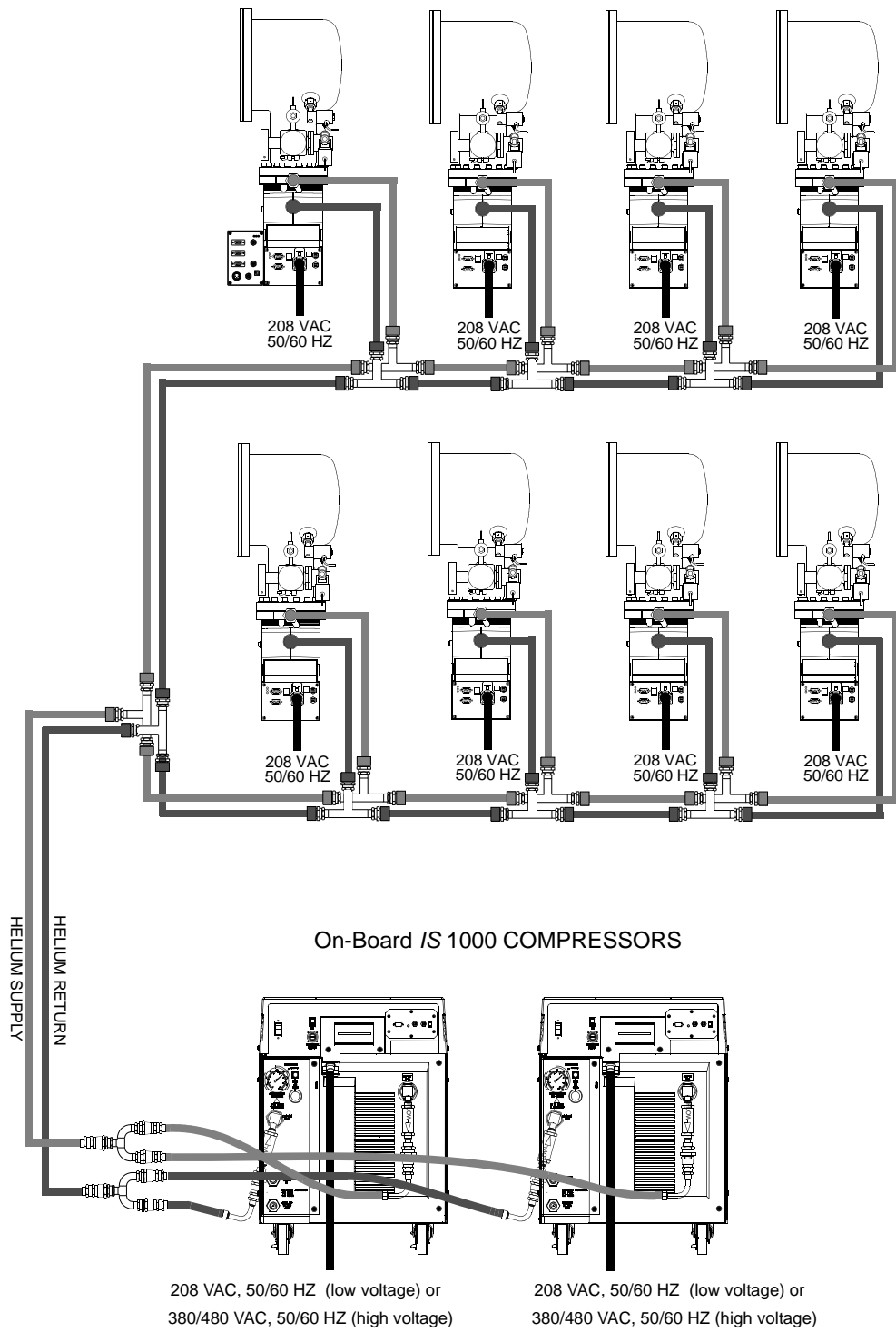

Figure 4-7: Multiple On-Board IS 1000 Compressor - Multiple On-Board IS Cryopump Configuration

Protection from Seismic Events

The On-Board IS 1000 Compressor unit is designed to be secured from movement and overturning in the case of a seismic event. This is to prevent risk of injury to personnel and equipment damage in compliance with semi-S2, section 19.

Brooks Automation offers an optional seismic mount kit (8187012K001) to secure the compressor. The mount can be installed using the *On-Board IS 1000 Compressor Seismic Mount Kit Quick Installation Guide* (8040704).

If you choose to mount your own device, please use the following guidelines.

Before You Start

Before installing a seismic mount:

1. Disconnect the On-Board IS 1000 Compressor from all electrical, gas and water connections.
2. Disconnect any On-Board IS 1000 Compressor pump connections.
3. Use a lifting device that can safely lift and hold the On-Board IS 1000 Compressor as indicated in Step 1 of the [Attaching a Seismic Mount to an On-Board IS 1000 Compressor](#) procedure below.

Attaching a Seismic Mount to an On-Board IS 1000 Compressor

To attach a seismic mount to the compressor:

1. Use a lifting device that can safely lift and hold the On-Board IS 1000 Compressor (222 lbs [102 kg]) so that you can safely access the bottom.
2. Place mounting blocks for added safety to ensure that the compressor is secure and stationary.
3. Use a 7/16" wrench or socket to remove the eight 1/4-20 x 0.75 hex bolts (PN MS35307-305) and 1/4" lock washer (PN 7001015P008) that secure each of the four casters at the bottom of the compressor. See [Figure 4-8 on page 4-18](#) for bolt and caster locations.

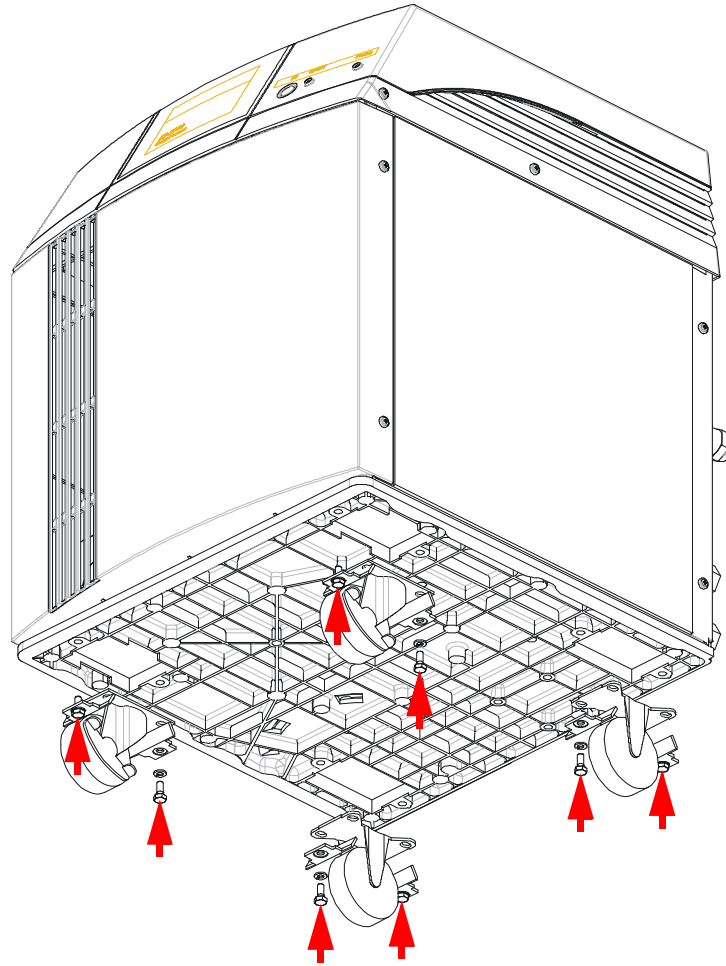

REMOVE CASTER HEX BOLTS

Figure 4-8: Removing the Caster Hex Bolts from the Compressor Bottom

4. If you raised the unit using a lifting device, remove the mounting blocks and carefully, slowly and safely lower the IS 1000 Compressor to the mounting locations.

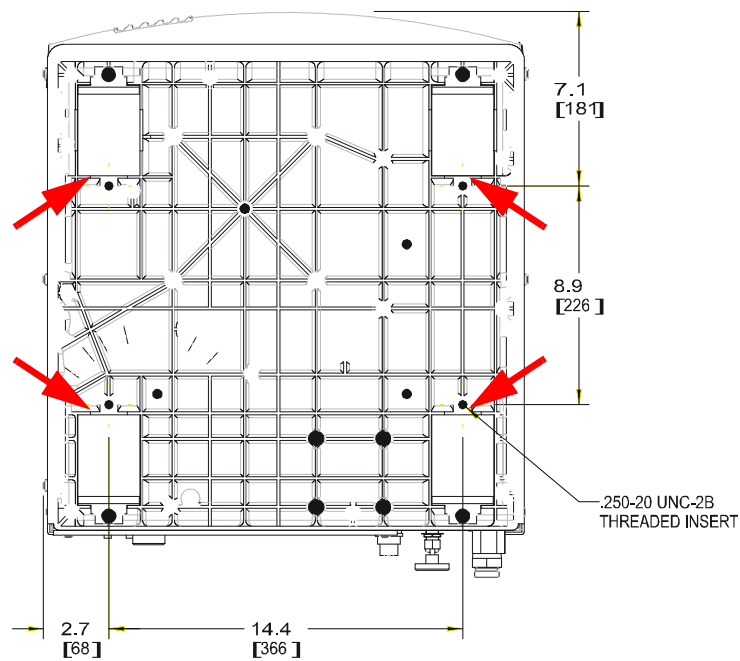

ATTACH SEISMIC MOUNTS AT POINTS INDICATED

Figure 4-9: Seismic Mount Mounting Points

5. Attach the seismic mounts to the four 1/4-20 mounting points shown in [Figure 4-9](#).

This Page Intentionally Left Blank

5 Operation

Overview

This chapter provides operation instructions for the Brooks Automation Product.

Chapter Contents

Adjusting System Helium Pressure	5-2
OFF Condition Helium System Pressure Verification	5-3
Compressor Operation	5-4
Replacement of Helium Circuit Components	5-6

Adjusting System Helium Pressure

Your high vacuum pump system is comprised of several pressurized components i.e. compressor, flex lines, and cryopumps. Each component is charged with helium before shipment. After all cryopumps, helium lines, and manifolds are attached to the compressor, the system *helium charge pressure (OFF condition)* must be verified *before* system operation. Once the helium system pressure (OFF condition) has been verified, the system is ready for operation. After cooldown, the *normal system operating pressure* is recorded.

NOTE: *The On-Board IS 1000 Compressor is designed for continuous operation and should remain ON even when the cryopumps are in a regeneration cycle.*

OFF Condition Helium System Pressure Verification

The proper system helium charge pressure (OFF condition) is necessary so that the cryopumps operate at maximum performance as well as to assure that the compressor will operate below the maximum design motor winding temperature which will maximize the life of the compressor motor.

1. Make sure the Compressor and Cryopump(s) are OFF.
2. Make sure all system components are connected together as described in [Installation on page 4-1](#).
3. Allow all system components to acclimate to a temperature between 60° F and 80° F (15.5° C - 26.6° C).
4. Read the compressor helium pressure gauge located on the compressor rear panel as shown in [Figure 1-1 on page 1-4](#). Compare the gauge reading to the appropriate 50/60 Hz line frequency value (depending upon your system installation) indicated in [Table 5-1](#).

Table 5-1: On-Board IS 1000 Compressor Helium Charge (OFF Condition)

Line Frequency	Helium Charge Pressure (OFF Condition)
60 Hz	340 - 350 psig (23.4 - 24.1 bar)
50 Hz	355 - 365 psig (24.5 - 25.2 bar)

NOTE: *The use of a higher helium charge pressure for 50 HZ operation is necessary in order to compensate for the slower speed at which the compressor operates at 50 HZ. The charge level (OFF condition) for 60 Hz remains at 340 - 350 PSIG.*

	<p>CAUTION</p> <p>Relief Valve Damage</p> <p>To avoid damaging relief valves, do not exceed the recommended system helium charge pressure (OFF condition).</p>
---	--

5. If the helium charge pressure (OFF condition) is not within the ranges as indicated in [Table 5-1](#), then adjust the charge pressure as described in [Maintenance on page 6-1](#).

Compressor Operation

	<p style="text-align: center;">CAUTION</p> <p style="text-align: center;">Equipment Damage</p> <p>To avoid damaging equipment from excessive or insufficient pressure, maintain between 140 psig and 240 psig.</p>
---	--

NOTE: *If the gauge indicator is below 140 psig, then check the system for insufficient helium or helium leaks. If the gauge indicator is above 240 psig, then the system has been over pressurized. Refer to [Maintenance on page 6-1](#) and either add or remove helium before operating the On-Board IS 1000 Compressor.*

The system may be operated once the helium charge pressure is correct. Perform the following steps to start the compressor:

1. Close all On-Board IS Cryopump gate valves.
2. Set the On-Board IS 1000 Compressor System Circuit Breaker to the ON (UP) position.
3. Set the On-Board IS 1000 Compressor Control Circuit Breaker to the ON (UP) position.
4. Set the power switch on the front panel of the On-Board IS 1000 Compressors to the ON position.
5. Refer to **Section 1** of the *On-Board IS Cryopump System Operation Guide*, part number 8040647 (that came with your On-Board IS Controller) for additional system startup information.
6. Once the second stage temperature for all cryopumps is below 17K, record the compressor pressure gauge reading as the *normal system operating pressure*.

NOTE: *During compressor operation, the compressor gauge reads the pressure of the gas entering the compressor prior to it being compressed.*

7. Affix a copy of the data next to the compressor gauge on each compressor. This data is to be verified for each tool installation and whenever a configuration change is made affecting the amount of system helium gas and line volume.

The compressor pressure reading will decrease from the normal system operating pressure during cryopump regeneration or if fewer cryopumps are being

operated. These are normal variations in the compressor pressure reading and should not be cause for concern.

NOTE: *If you have concerns about system performance changing, then check the normal system operating pressure which was determined in [Compressor Operation on page 5-4](#). If the normal system operating pressure is not correct, check the system for leaks.*

Once the leaks have been repaired, helium must be added to return the system to *normal operating system pressure* as described in [Maintenance on page 6-1](#).

Replacement of Helium Circuit Components

On occasion, it may be necessary to replace components such as cryopumps, helium gas lines or compressors, or change the configuration of the system. Whenever any of these conditions occur, [OFF Condition Helium System Pressure Verification on page 5-3](#) should be performed to ensure that (OFF condition) helium pressure has not changed.

	<p style="text-align: center;">CAUTION</p> <p style="text-align: center;">Relief Valve Damage</p> <p>To avoid damaging relief valves when using other compressor models, reduce the system helium charge pressure to 200 - 210 psig.</p>
---	--

The use of several On-Board IS 1000 Compressors on a single manifold feeding a common supply header and a common return header requires special precautions. Contact Brooks Automation for a review of the intended installation and for specific technical instructions.

6

Maintenance

Overview

This chapter provides maintenance directions for the Brooks Automation Product.

Chapter Contents

Scheduled Maintenance	6-2
Suggested Maintenance Equipment	6-2
Adsorber Replacement	6-2
Adjusting System Helium Pressure	6-5
Reducing Helium Pressure	6-5
Increasing Helium Pressure	6-6
Adding Helium	6-6

Scheduled Maintenance

Suggested Maintenance Equipment

It is recommended to have the following equipment and disposable supplies available as listed in [Table 6-1](#).

Table 6-1: Suggested Maintenance Equipment

Supply	Part Number
Helium, 99.999% pure	-
Pressure regulator (0-3000/0-400 psi) Assy.	8031403
Helium charging line terminating in a 1/ 4-inch female flare fitting	7021002P001
Lint-free gloves and cloth	-
Oakite or equivalent detergent soap	-
Denatured alcohol	-
<p>NOTE: <i>NOTE: Refer to Appendix A: Customer Brooks Automation Technical Support Information on page 7-2 and contact your local Brooks Automation Support Center to obtain the parts listed in this table.</i></p> <p>NOTE: <i>NOTE: MSDS sheet for oil used in the compressor is available upon request.</i></p>	

Adsorber Replacement

Use the following procedure to replace the adsorber every three years.

1. Set the System Circuit Breaker, on the rear of the On-Board IS 1000 Compressor, to the OFF position.
2. Remove the four screws which secure the rear panel to the Compressor and remove the rear panel.

NOTE: *Use two wrenches in Step 3 to prevent loosening the body of the coupling.*

3. Using a 1-3/16 in. wrench, and a 1-1/8 in. wrench, as shown in [Figure 6-1 on page 6-3](#), disconnect the two self sealing coupling connectors quickly to minimize helium leakage.

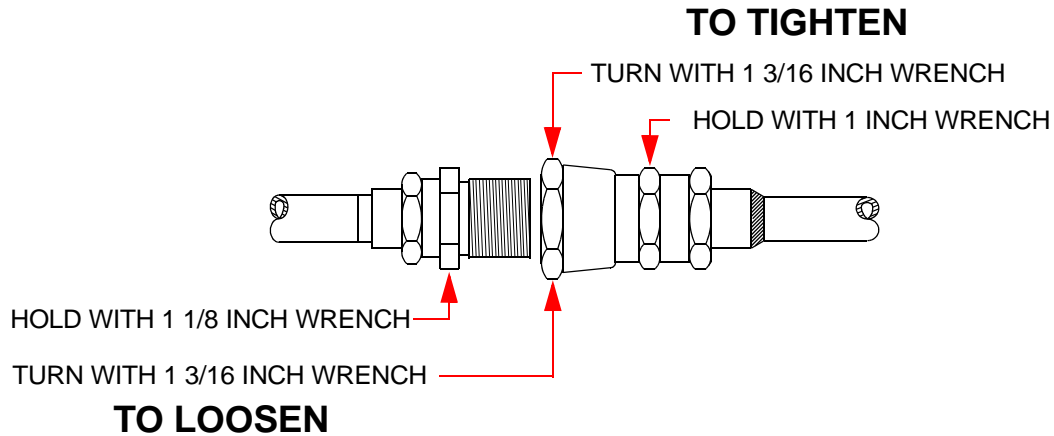

Figure 6-1: Disconnecting Self Sealing Couplings

- Using a 7/16 in. (11mm) wrench, remove the adsorber mounting bolt as shown in [Figure 6-2 on page 6-4](#).
- Move the adsorber from under the mounting tabs in the base as shown in [Figure 6-2 on page 6-4](#) and remove the adsorber from the Compressor.
- Install the replacement adsorber under the mounting tabs and secure it into place with the bolt removed in [Step 4](#).
- Using two wrenches as shown in [Figure 6-1](#), connect the two self sealing couplings quickly to minimize helium leakage.
- Install the Compressor rear panel.
- Ensure that the pressure gauge reads the proper value as shown in [Table 5-1 on page 5-3](#). If additional gas pressure is required, refer to **Adding Helium** within this section. If gas pressure needs to be reduced, refer to **Reducing Helium Pressure** within this section.
- Record the adsorber replacement date on the adsorber label and also note that the next adsorber replacement should be performed in three years.

NOTE: Follow local, state and federal guidelines when disposing of the adsorber.

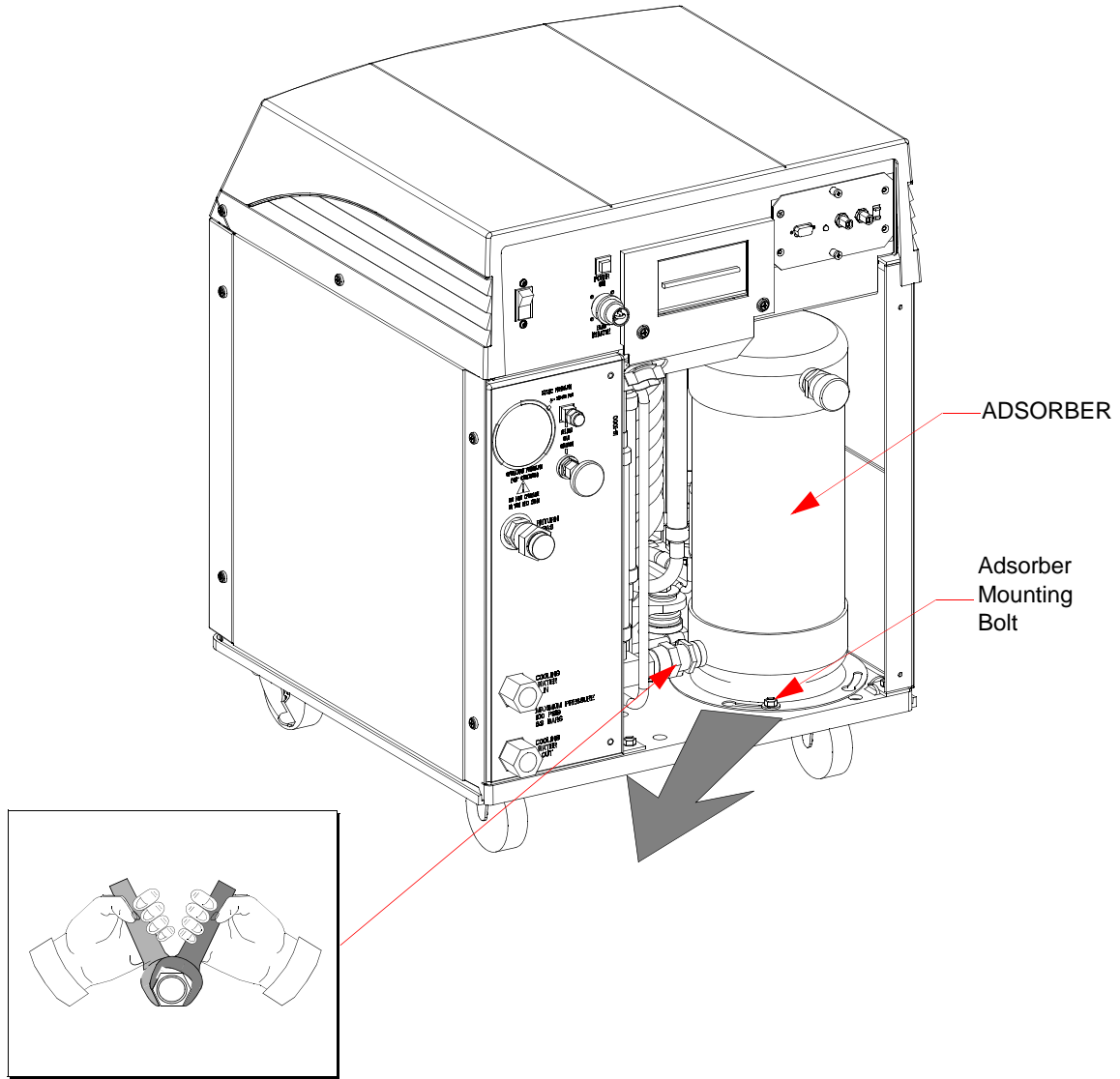

Figure 6-2: Adsorber Location within the On-Board IS 1000 Compressor
(Rear Panel Removed)

Adjusting System Helium Pressure

NOTE: *These procedures can be performed on a compressor that is turned ON or OFF. However, the helium pressure gauge should be set to the helium charge pressure (OFF condition) value if the compressor is turned OFF or set to the normal system operating pressure if the compressor is turned ON. Refer to [Operation on page 5-1](#) for more information.*

Reducing Helium Pressure

NOTE: *You must obtain the normal system operating pressure from [Table 5-1 on page 5-3](#) in order to perform this procedure. If the normal system operating pressure is unknown, then shut the compressor OFF and perform the [OFF Condition Helium System Pressure Verification on page 5-3](#) procedure instead.*

1. Remove the flare cap from the gas charge flared fitting as shown in [Figure 6-3](#).

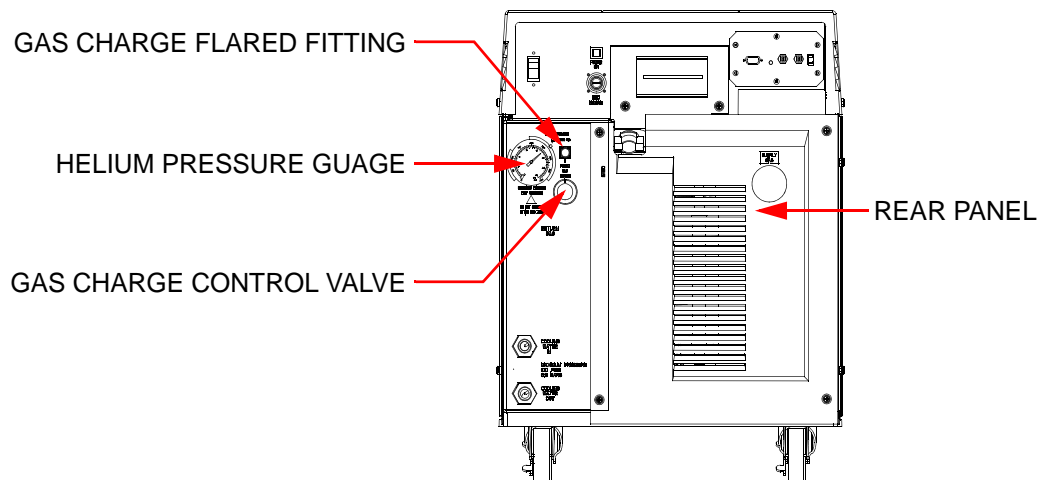



Figure 6-3: Helium Pressure Control Components

2. Open the gas charge control valve *very slowly* to allow a slight amount of helium to escape. Leave the valve open until the helium pressure gauge indicates one of the following:
 - To the appropriate value in [Table 5-1 on page 5-3](#) if the compressor is OFF and acclimated to a temperature between 60° F and 80° F (15.5° C - 26.6° C).
 - To the value previously recorded in the [Compressor Operation on page 5-4](#) procedure if the compressor is ON.
3. Close the gas charge control valve and replace the flare cap.

Increasing Helium Pressure

Use the following procedure to increase the helium pressure if the indicated pressure is below the appropriate value as shown in [Table 5-1 on page 5-3](#).

	<p style="text-align: center;">CAUTION</p> <p style="text-align: center;">Equipment Damage</p> <p>To avoid damaging equipment due to insufficient helium, check for leaks if helium must be added to the system more than once every few months. A helium leak may be caused by improperly connected self-sealing connections or any mechanical joint within the compressor</p>
---	---

Adding Helium

NOTE: *You must obtain the normal system operating pressure from [Table 5-1 on page 5-3](#) in order to perform this procedure. If the normal system operating pressure is unknown, then shut the compressor OFF and perform the **OFF Condition Helium System Pressure Verification on page 5-3** procedure instead.*

This procedure ensures that both the regulator and the charging line will be purged of air and that the air trapped in the regulator will not diffuse back into the helium bottle. For best results, use a dedicated helium bottle, regulator, and line, which are never separated, for adding helium.

NOTE: *You are required to supply the helium charging line terminating in a 1/4-inch female flare fitting, and a two-stage pressure regulator rated at 0-3000/0-400 psig for this operation.*

	<p style="text-align: center;">CAUTION</p> <p style="text-align: center;">Equipment Failure</p> <p>Use only 99.999% pure helium gas. Helium circuit contamination may result if a lower quality of helium is used.</p>
---	--

1. Attach a regulator (0-3000/0-400 psig) and charging line to a helium bottle (99.999% pure).

NOTE: *Do not open the bottle at this time.*

2. Purge the regulator and charging lines as follows:
 1. Open the regulator a small amount by turning the adjusting knob clockwise until it contacts the diaphragm, then turn approximately 1/8 to 1/4 turn more, so that the regulator is barely open.
 2. Loosely connect the charge line to the helium pressure regulator.
 3. Slowly open the bottle valve, and purge the regulator and line for 10 to 15 seconds. Turn the regulator knob counterclockwise until the helium stops flowing.
3. Remove the flare cap of the gas charge flared fitting on the rear of the Compressor.
4. Loosely connect the charging line from the helium pressure regulator to the 1/4-inch male flare fitting installed on the helium charge valve. Purge the charge line again, as in step a, for 30 seconds, and tighten the charge line flare fitting onto the gas charge fitting while the helium is flowing.
5. Set the helium pressure regulator to 300 psig (20.7 bars). If the compressor is ON, proceed with step a. If the compressor is OFF, proceed with [Step 2](#).
 1. Obtain the previously recorded normal system operating pressure operating pressure from [Table 5-1 on page 5-3](#). Open the gas charge control valve *very slowly* and allow helium to flow until the compressor gauge reading is the same as the value obtained from Section 4. Quickly close the gas charge control valve. [Table 5-1 on page 5-3](#)
 2. Obtain the appropriate (50 or 60 Hz) *system operating pressure (OFF condition)* from [Table 5-1 on page 5-3](#). Open the gas charge control valve *very slowly* and allow helium to flow until the compressor gauge reading is the same as the appropriate value in [Table 5-1 on page 5-3](#). Quickly close the gas charge control valve.
6. Ensure that the helium charge valve on the Compressor is tightly closed. Shut off the helium pressure regulator on the helium bottle and remove the charging line from the male flare fitting. Reinstall the flare cap.

This Page Intentionally Left Blank

7

Appendices

Overview

The following appendices are included to provide the user with a single location for specific information related to the Brooks Automation Product.

Chapter Contents

Appendix A: Customer Brooks Automation Technical Support Information . . .	7-2
Appendix B: Troubleshooting Procedures	7-3
Troubleshooting the Compressor	7-3
Technical Inquiries	7-3
Front Panel Indicators	7-3
Appendix C: Diagrams	7-9

Appendix A: Customer Brooks Automation Technical Support Information

When contacting Brooks Automation for Technical Support, please have the following information available.

1. Record the part number and serial number from the equipment.
2. Provide the installed location of the equipment.
3. Provide name, e-mail address, and telephone number of the person to contact.
4. List any error codes received during the failure.
5. Prepare a detailed description of the events relating to the error.
 - Time that the equipment has been in operation
 - Work that was done on the equipment prior to the error
 - Functions that the equipment was performing when the error occurred
 - Actions taken after the error and the results of those actions
 - Other information that may assist the Specialist
6. Contact Brooks Automation Technical Support at these numbers:

Brooks Location	GUTS[®] Contact Number
North America	1-800-FOR-GUTS (1-800-367-4887) US/Canada +1-978-262-2900
Europe	+49 1804 CALL GUTS (+49 1804 2255 4887)
Japan	+81-45-477-5980
China	+86-21-5131-7066
Taiwan	+886-3-552-5225
Korea	+82-31-288-2500
Singapore	+65-6464-1481

For additional contact information, please go to the Brooks Automation web site at www.brooks.com or send an E-mail to techsupport@brooks.com.

Appendix B: Troubleshooting Procedures

Troubleshooting the Compressor

The Compressor troubleshooting procedures are summarized in [Table 7-1 on page 7-4](#).

NOTE: *Disconnect the compressor before performing any troubleshooting procedures.*

	<p style="text-align: center;">CAUTION</p> <p style="text-align: center;">Hot Surface</p> <p>To avoid burns, wait for the pump to cool down before working on the inside of the compressor.</p>
---	---

	<p style="text-align: center;">CAUTION</p> <p style="text-align: center;">Compressor Damage</p> <p>To avoid damaging the compressor, do not change or modify any compressor internal wiring circuits.</p>
--	---

Technical Inquiries

NOTE: *Refer to [Appendix A: Customer Brooks Automation Technical Support Information on page 7-2](#) for customer support information and contact Brooks Automation for assistance if required.*

Front Panel Indicators

The On-Board IS 1000 Compressor front panel contains two indicators; a green power indicator and a red status indicator as shown in [Figure 7-1 on page 7-4](#). When the red status indicator is illuminated, a fault condition exists. Refer to [Table 7-1 on page 7-4](#) to locate the problem.

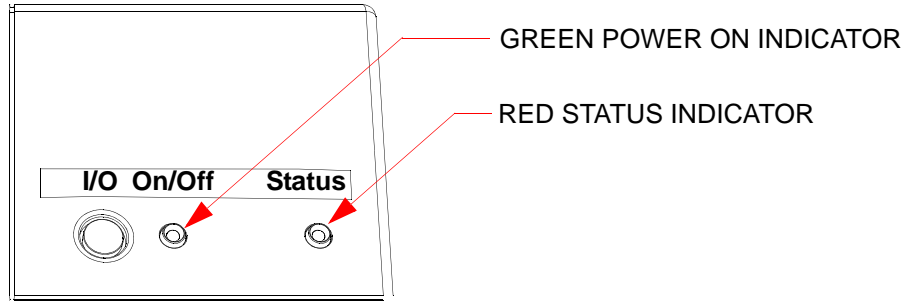

Figure 7-1: On-Board IS 1000 Compressor Front Panel Indicators

Table 7-1: Compressor Troubleshooting Procedures

Problem	Possible Cause	Corrective Action
1. System circuit breaker (CB1) trips immediately to the OFF (0) position when switched to the ON (1) position. Power Indicator OFF Status Indicator OFF	1a. Incorrect phasing of input power.	1a. Check phasing of input power. Refer to Phase Check on page 4-13 .

Table 7-1: Compressor Troubleshooting Procedures

Problem	Possible Cause	Corrective Action
<p>2. System (CB1) and Control Circuit (CB2) circuit breakers remain in the ON (1) position when switched ON but the compressor will not run. Power Indicator OFF Status Indicator OFF</p>	<p>2a. No power coming from source.</p>	<p>2a. Check source fuses, circuit breakers, and wiring associated with the power source. Repair as needed.</p>
	<p>2b. Insufficient power.</p>	<p>2b. Verify adequate phase-to-phase input voltage. Refer to Table 1-1 on page 1-6.</p>
	<p>2c. EMO remote jumper plug is not properly installed.</p>	<p>2c. Check that the EMO remote jumper plug is fully seated. See Figure 6-1 on page 6-3 for location. Refer to EMO Remote Operation and EMO Box Installation on page 4-9 for more information. Reset the CB1 circuit breaker.</p>
	<p>2d. Improperly wired external EMO remote control circuit. <i>NOTE: Only applies if EMO remote control feature is being used.</i></p>	<p>2d. Verify correct installation of EMO remote control feature.</p>
<p>3. System circuit breaker (CB1) will not remain in the ON (1) position when switched ON. The Control Circuit circuit breaker (CB2) trips when excessive current is being drawn by 24 volt compressor control circuits. Power Indicator OFF Status Indicator OFF</p>	<p>3a. Damaged component in the compressor power or control circuit.</p>	<p>3a. Refer to Appendix A: Customer Brooks Automation Technical Support Information on page 7-2 and contact your local Brooks Automation Customer Support Center.</p>

Table 7-1: Compressor Troubleshooting Procedures

Problem	Possible Cause	Corrective Action
<p>4. System circuit breaker (CB1) remains in the ON (1) position and the compressor stops after several minutes of operation and remains OFF (0). Power Indicator OFF Status Indicator ON</p>	<p>4a. Thermal protective switches are open.</p>	<p>4a. Check for inadequate water cooling. Refer to Table 1-3 on page 1-7.</p>
	<p>4b. Very cold water has caused a restriction of oil flow through the oil injection orifice during start-up.</p>	<p>4b. Recheck for proper cooling water temperature. Refer to Table 1-3 on page 1-7. Restart compressor repeatedly until continuous operation is achieved. NOTE: The control circuit breaker will have to be reset if the compressor has shutdown three times.</p>
	<p>4c. Defective compressor motor.</p>	<p>4c. Refer to Appendix A: Customer Brooks Automation Technical Support Information on page 7-2 and contact your local Brooks Automation Customer Support Center.</p>
<p>5. System circuit breaker (CB1) trips after a period of running. Power Indicator OFF Status Indicator OFF</p>	<p>5a. Loss or degradation of power from the source.</p>	<p>5a. Check that line voltage is correct on all phases.</p>
	<p>5b. Defective motor windings.</p>	<p>5b. Check running current on all phases. Refer to Appendix A: Customer Brooks Automation Technical Support Information on page 7-2 and contact your local Brooks Automation Customer Support Center.</p>

Table 7-1: Compressor Troubleshooting Procedures

Problem	Possible Cause	Corrective Action
<p>6. Compressor has been automatically shut off. CB1 and CB2 are in the ON (1) position. Power Indicator OFF Status Indicator ON</p>	<p>6a. Cooling water temperature or heat exchanger temperature is too high.</p>	<p>6a. Refer to Table 1-3 on page 1-7 and verify proper operation of facility cooling water.</p>
	<p>6b. Compressor Motor Temperature is too high.</p>	<p>6b. Check the voltage on the three input legs. Check the current on the three input legs. Refer to Appendix A: Customer Brooks Automation Technical Support Information on page 7-2 and contact your local Brooks Automation Customer Support Center.</p>
	<p>6c. Voltage has been lower than 342 VAC @ 60 Hz for longer than 60 minutes.</p>	<p>6c. Check voltage. Refer to Appendix A.</p>
	<p>6d. Voltage has been 342 VAC, 60 Hz with insufficient water flow of 3.25 gpm for 60 minutes.</p>	<p>6d. Increase water flow rate to 3.25 gpm. Refer to Appendix A: Customer Brooks Automation Technical Support Information on page 7-2.</p>
<p>7. CB1 and CB2 in ON (1) position but compressor will not run or start. Power Indicator OFF Status Indicator OFF</p>	<p>7a. Front panel power switch in OFF position.</p>	<p>7a. Set front panel power switch to ON position.</p>

Table 7-1: Compressor Troubleshooting Procedures

Problem	Possible Cause	Corrective Action
<p>8. Compressor is running. Power Indicator ON Status Indicator ON</p>	<p>8a. Cooling water temperature is out of range.</p>	<p>8a. Refer to Appendix A: Customer Brooks Automation Technical Support Information on page 7-2 and verify proper operation of facility cooling water.</p>
	<p>8b. Helium Supply/Return pressure ratio is below 150 psig.</p>	<p>8b. Refer to Section 4 and verify OFF Condition Helium System Pressure Verification on page 5-3.</p>
	<p>8c. Helium Return pressure is below 100 psig.</p>	<p>8c. Check for loose helium flex line couplings or leaks.</p>
	<p>8d. Defective component.</p>	<p>8d. Refer to Appendix A: Customer Brooks Automation Technical Support Information on page 7-2 and contact your local Brooks Automation Customer Support Center.</p>

Appendix C: Diagrams

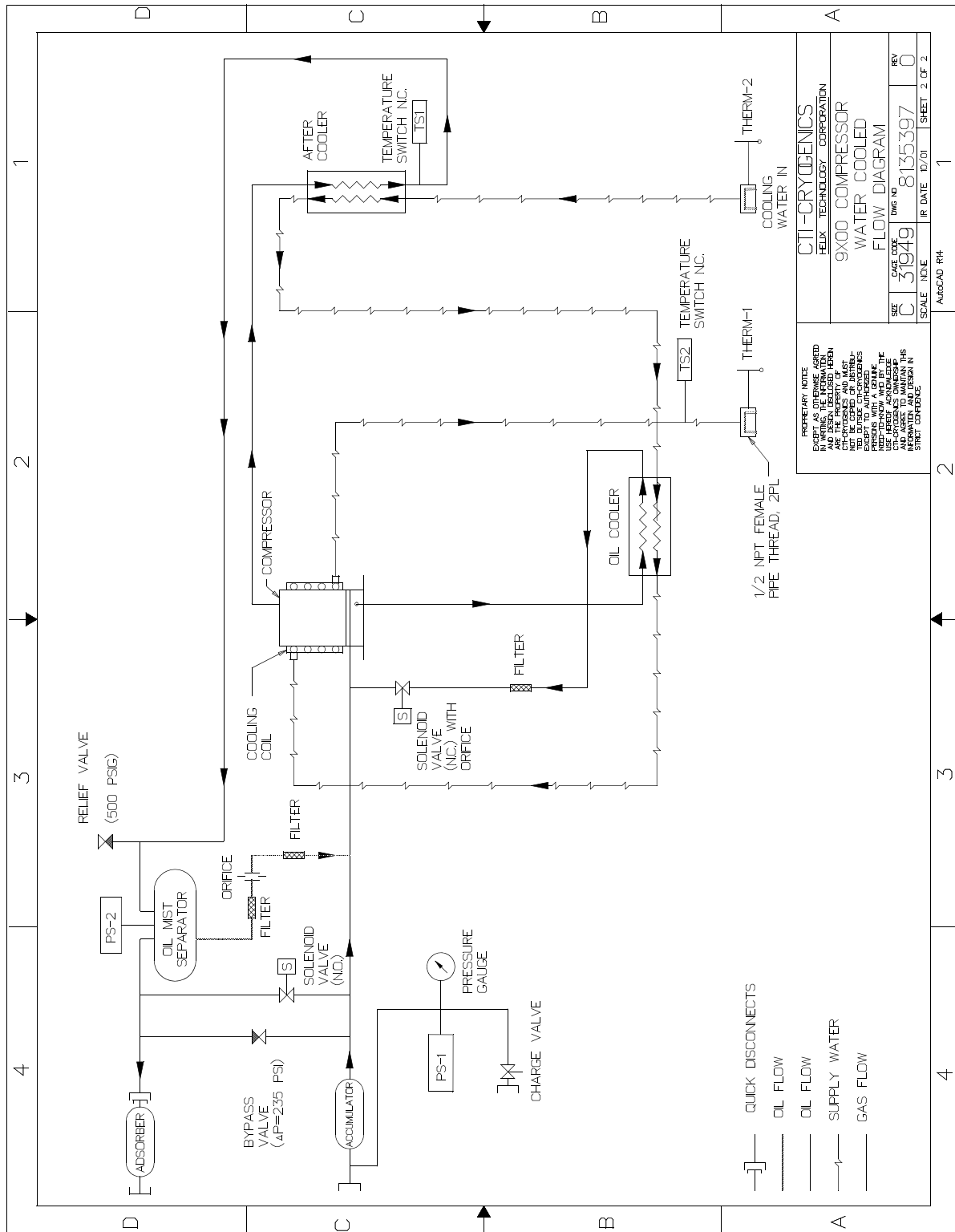

Figure 7-2: On-Board IS 1000 Compressor Helium Flow Diagram

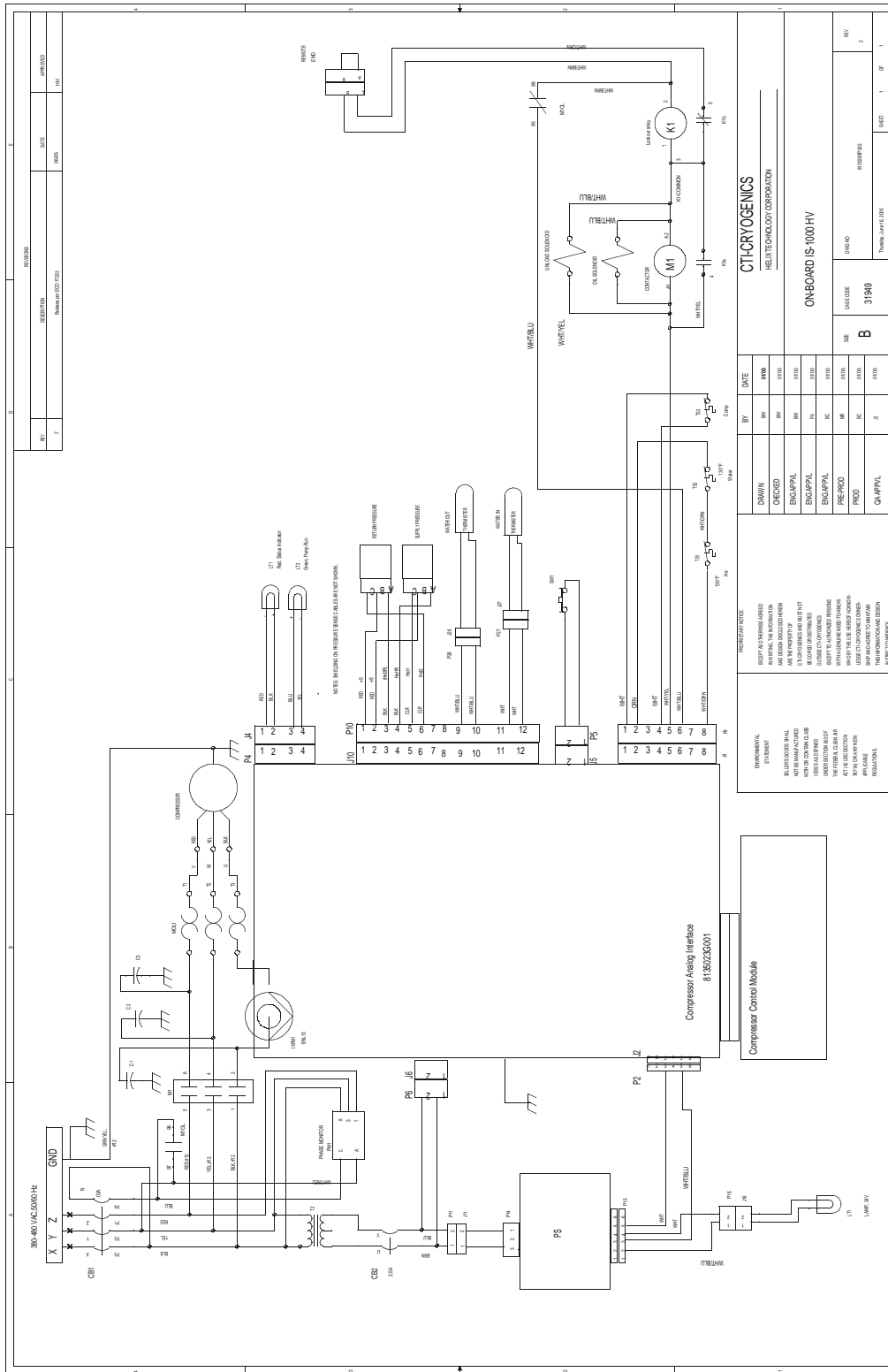

Figure 7-3: On-Board IS 1000 Compressor Electrical Schematic

(8135399P002, High Voltage)

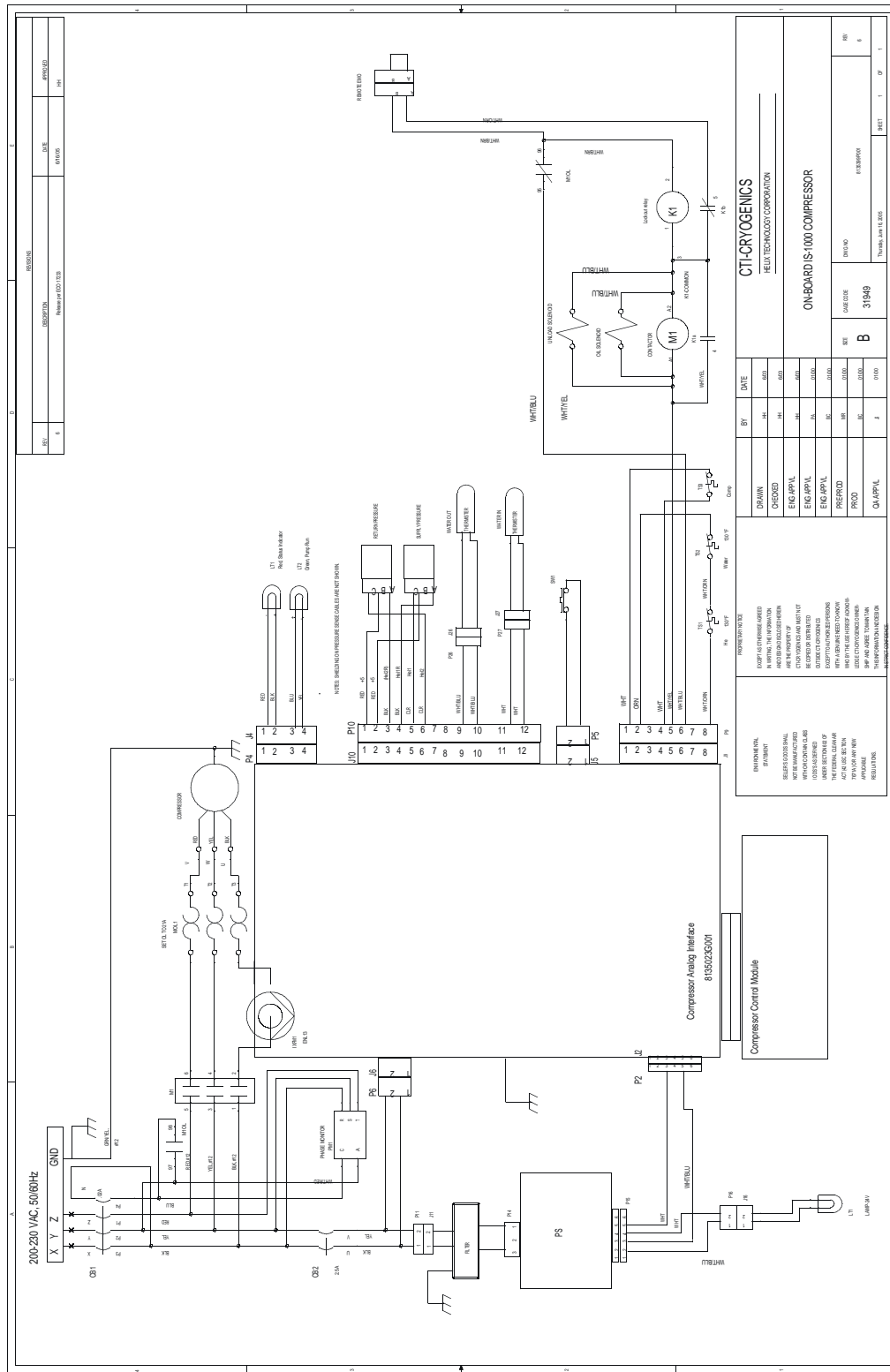

Figure 7-4: On-Board IS 1000 Compressor Electrical Schematic
(8135399P001, Low Voltage)

This Page Intentionally Left Blank