



FOR SALES AND SERVICE PLEASE CALL:

PTB SALES T :: 626.334.0500
service@ptbsales.com
www.ptbsales.com

DATE SERVICED: _____

VIEW OUR INVENTORY

Turbo-V 70D pumps

969-9361 series
969-9362 series
969-9363 series
969-9364 series

MANUALE DI ISTRUZIONI

BEDIENUNGSHANDBUCH

NOTICE DE MODE D'EMPLOI

MANUAL DE INSTRUCCIONES

MANUAL DE INSTRUÇÕES

BEDRIJFSHANDLEIDING

INSTRUKSTIONSBOG

BRUKSANVISNING

INSTRUKSJON MANUAL

OHJEKÄSIKIRJA

ΟΔΗΓΙΕΣ ΧΡΗΣΕΩΣ

INSTRUCTION MANUAL

Turbo-V 70D



VARIAN



vacuum technologies

Dear Customer,

Thank you for purchasing a VARIAN vacuum product. At VARIAN Vacuum Technologies we make every effort to ensure that you will be satisfied with the product and/or service you have purchased.

As part of our Continuous Improvement effort, we ask that you report to us any problem you may have had with the purchase or operation of our product. On the back side you find a Corrective Action Request form that you may fill out in the first part and return to us.

This form is intended to supplement normal lines of communications and to resolve problems that existing systems are not addressing in an adequate or timely manner.

Upon receipt of your Corrective Action Request we will determine the Root Cause of the problem and take the necessary actions to eliminate it. You will be contacted by one of our employees who will review the problem with you and update you, with the second part of the same form, on our actions.

Your business is very important to us. Please, take the time and let us know how we can improve.

Sincerely,

Sergio PIRAS

*Vice President and General Manager
VARIAN Vacuum Technologies*

Note: Fax or mail the Customer Request for Action (see backside page) to VARIAN Vacuum Technologies (Torino) - Quality Assurance or to your nearest VARIAN representative for onward transmission to the same address.

CUSTOMER REQUEST FOR CORRECTIVE / PREVENTIVE / IMPROVEMENT ACTION

TO : VARIAN VACUUM TECHNOLOGIES TORINO - QUALITY ASSURANCE

FAX N° : XXXX - 011 - 9979350

ADDRESS: VARIAN S.p.A. - Via F.lli Varian, 54 - 10040 Leinì (Torino) - Italy

E-MAIL : marco.marzio@varianinc.com

NAME _____	COMPANY _____	FUNCTION _____
<p>ADDRESS : _____</p> <p>TEL. N° : _____ FAX N° : _____</p> <p>E-MAIL : _____</p>		
<p>PROBLEM / SUGGESTION :</p> <p>_____</p> <p>_____</p> <p>_____</p> <p>_____</p>		
<p>REFERENCE INFORMATION (model n°, serial n°, ordering information, time to failure after installation, etc.) :</p> <p>_____</p> <p>_____</p> <p>_____</p> <p style="text-align: right;">DATE _____</p>		

<p>CORRECTIVE ACTION PLAN / ACTUATION (by VARIAN VTT)</p> <p>_____</p> <p>_____</p> <p>_____</p> <p>_____</p> <p>_____</p>	<p>LOG N° _____</p>
--	---------------------

XXXX = Code for dialing Italy from your country (es. 01139 from USA; 00139 from Japan, etc.)



ISTRUZIONI PER L'USO	1
GEBRAUCHSANLEITUNG.....	3
MODE D'EMPLOI	5
INSTRUCCIONES DE USO	7
INSTRUÇÕES PARA O USO	9
GEBRUIKSAANWIJZINGEN	11
BRUGSANVISNING	13
BRUKSANVISNING.....	15
BRUKERVEILEDNING	17
KÄYTTÖOHJEET	19
ΠΛΗΓΙΕΣ ΧΡΗΣΕΩΣ	21
INSTRUCTIONS FOR USE.....	23
TECHNICAL INFORMATION	25
DESCRIPTION OF THE TURBOPUMP	25
TECHNICAL SPECIFICATION.....	26
INLET SCREEN INSTALLATION.....	28
HEATER BAND INSTALLATION	29
WATER COOLING KIT INSTALLATION.....	30
BASE FIXING KIT INSTALLATION.....	31
AIR COOLING KIT INSTALLATION.....	32
VENT VALVE INSTALLATION.....	33
VENT DEVICE INSTALLATION.....	33
TYPICAL LAYOUT DIAGRAM	34
Connection A - HIGH VACUUM FLANGE	35
Connection configurations.....	35
Connection B - FORE-VACUUM PUMP	36
Connection C - ELECTRICAL.....	36
ACCESSORIES.....	36

INFORMAZIONI GENERALI

Questa apparecchiatura è destinata ad uso professionale. L'utilizzatore deve leggere attentamente il presente manuale di istruzioni ed ogni altra informazione addizionale fornita dalla Varian prima dell'utilizzo dell'apparecchiatura. La Varian si ritiene sollevata da eventuali responsabilità dovute all'inosservanza totale o parziale delle istruzioni, ad uso improprio da parte di personale non addestrato, ad interventi non autorizzati o ad uso contrario alle normative nazionali specifiche.

Le pompe della serie Turbo-V 70D sono pompe turbomolecolari per applicazioni di alto e ultra alto vuoto, capaci di pompare qualsiasi tipo di gas o di composto gassoso. Non sono adatte per il pompaggio di liquidi o di particelle solide.

L'effetto pompante è ottenuto tramite una turbina rotante ad elevata velocità (75000 giri/min. max) mossa da un motore elettrico trifase ad alto rendimento. Le pompe Turbo-V 70D sono totalmente prive di agenti contaminanti, e sono quindi adatte per applicazioni che richiedono un vuoto "pulito".

Nei paragrafi seguenti sono riportate tutte le informazioni necessarie a garantire la sicurezza dell'operatore durante l'utilizzo dell'apparecchiatura. Informazioni dettagliate sono fornite nell'appendice "Technical information".

Questo manuale utilizza le seguenti convenzioni:



PERICOLO!

I messaggi di pericolo attirano l'attenzione dell'operatore su una procedura o una pratica specifica che, se non eseguita in modo corretto, potrebbe provocare gravi lesioni personali.



ATTENZIONE!

I messaggi di attenzione sono visualizzati prima di procedure che, se non osservate, potrebbero causare danni all'apparecchiatura.

NOTA

Le note contengono informazioni importanti estrapolate dal testo.

IMMAGAZZINAMENTO

Per garantire il massimo livello di funzionalità ed affidabilità delle pompe Turbomolecolari Varian, devono essere osservate le seguenti prescrizioni:

- durante il trasporto, lo spostamento e l'immagazzinamento delle pompe non devono essere superate le seguenti condizioni ambientali:
 - temperatura: da -20 °C a 70 °C
 - umidità relativa: da 0 a 95% (non condensante)
- il cliente deve sempre avviare le pompe turbomolecolari nel modo Soft-Start quando ricevute e messe in funzione per la prima volta
- il tempo di immagazzinamento di una pompa turbomolecolare è di 10 mesi dalla data di spedizione.



ATTENZIONE!

Se, per qualsiasi ragione, il tempo di immagazzinamento è superiore, occorre reinviare la pompa in fabbrica. Per ogni informazione, si prega di contattare il locale rappresentante della Varian.

PREPARAZIONE PER L'INSTALLAZIONE

La pompa viene fornita in un imballo protettivo speciale; se si presentano segni di danni, che potrebbero essersi verificati durante il trasporto, contattare l'ufficio vendite locale.

Durante l'operazione di disimballaggio, prestare particolare attenzione a non lasciar cadere la pompa e a non sottoporla ad urti o vibrazioni.

Non disperdere l'imballo nell'ambiente. Il materiale è completamente riciclabile e risponde alla direttiva CEE 85/399 per la tutela dell'ambiente.



ATTENZIONE!

Onde evitare problemi di degassamento, non toccare con le mani nude i componenti destinati ad essere esposti al vuoto. Utilizzare sempre i guanti o altra protezione adeguata.

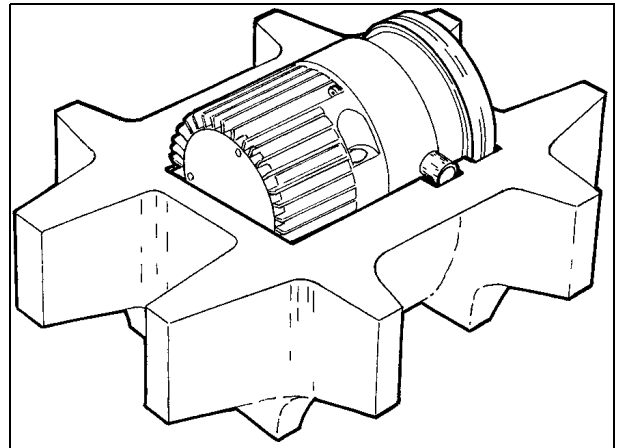

NOTA

La pompa non può essere danneggiata rimanendo semplicemente esposta all'atmosfera. Si consiglia comunque di mantenerla chiusa fino al momento dell'installazione sul sistema onde evitare eventuale inquinamento da polvere.

INSTALLAZIONE

Non installare e/o utilizzare la pompa in ambienti esposti ad agenti atmosferici (pioggia, gelo, neve), polveri, gas aggressivi, in ambienti esplosivi o con elevato rischio di incendio.

Durante il funzionamento è necessario che siano rispettate le seguenti condizioni ambientali:

- pressione massima: 2 bar
- temperatura: da + 5 °C a +35 °C
- umidità relativa: 0 - 95% (non condensante).

Le pompe turbomolecolari della serie Turbo-V 70D devono essere utilizzate solo con uno degli appositi controllori Varian (serie 969-9405, 969-9505, 969-9507e 969-9508) e devono essere collegate ad una pompa primaria (vedere schema in "Technical Information").

La turbopompa può essere installata in qualsiasi posizione. Fissare la turbopompa in posizione stabile collegando la flangia di ingresso della turbopompa ad una controflangia fissa capace di resistere ad una coppia di 200 Nm attorno al proprio asse, oppure utilizzando l'apposito kit opzionale per il fissaggio alla base.



ATTENZIONE!

Staccare l'adesivo e togliere il tappo di protezione solo al momento del collegamento della turbopompa al sistema.

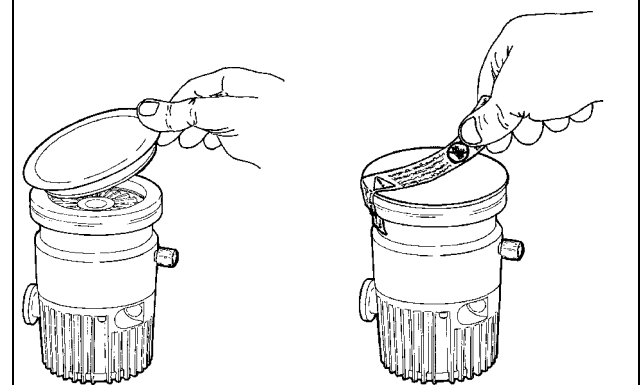



La turbopompa con flangia di ingresso ISO deve essere fissata alla camera da vuoto per mezzo di morsetti doppi o morsetti singoli. La seguente tabella descrive, per ogni dimensione flangia e tipo di morsetto, il numero di morsetti necessari e con quale coppia di serraggio stringerli.

FLANGIA	TIPO DI MORSETTO	N.	COPPIA DI SERRAGGIO
ISO 63	Morsetto doppio con filettatura M10	4	22 Nm
	Morsetto singolo con filettatura M8	4	11 Nm

La turbopompa con flangia di ingresso ConFlat deve essere fissata alla camera da vuoto per mezzo dell'apposita minuteria meccanica Varian. Per ulteriori dettagli vedere l'appendice "Technical Information".

Per fissare la pompa per mezzo della sua base, è necessario utilizzare tre viti M4 fissate agli appositi fori presenti sulla base della pompa. Le viti utilizzate devono avere un carico di snervamento di 500 N/mm² e devono essere fissate con una coppia di 0,9 Nm.

Per l'installazione degli accessori opzionali, vedere "Technical Information".

USO

Tutte le istruzioni per il corretto funzionamento della turbopompa sono contenute nel manuale dell'unità di controllo.

Leggere attentamente tale manuale prima dell'utilizzo.

Per raggiungere migliori pressioni limite è possibile riscaldare l'involucro della pompa utilizzando il riscaldatore opzionale.

Durante l'eventuale riscaldamento della camera da vuoto, la temperatura sulla flangia di ingresso non deve essere superiore a 120 °C.

Utilizzare sempre il raffreddamento ad acqua durante le operazioni di riscaldamento.



PERICOLO!

Non toccare la turbopompa e i suoi eventuali accessori durante le operazioni di riscaldamento. L'elevata temperatura può causare lesioni alle persone.



ATTENZIONE!

Per la mandata all'aria della pompa utilizzare aria o gas inerte esente da polvere o particelle. La pressione di ingresso attraverso l'apposita porta deve essere inferiore a 2 bar.



ATTENZIONE!

Evitare urti, oscillazioni o bruschi spostamenti della turbopompa quando è in funzione. I cuscinetti potrebbero danneggiarsi.



ATTENZIONE!

Per il pompaggio di gas aggressivi utilizzare solo le versioni speciali della pompa Turbo - V 70D. Tali pompe sono dotate di una apposita porta attraverso la quale è necessario fornire alla pompa un flusso di gas inerte compreso tra 0,4 e 1 mbar l/s.

MANUTENZIONE

Le pompe della serie Turbo-V70D non richiedono alcuna manutenzione. Qualsiasi intervento deve essere eseguito da personale autorizzato.



PERICOLO!

Prima di effettuare qualsiasi intervento sulla turbopompa scollegare il connettore di alimentazione, mandare all'aria la pompa aprendo l'apposita valvola ed attendere fino al completo arresto del rotore ed attendere che la temperatura superficiale della pompa sia inferiore a 50 °C.

In caso di guasto è possibile usufruire del servizio di riparazione Varian o del "Varian advanced exchange service", che permette di ottenere una pompa rigenerata in sostituzione di quella guasta.

NOTA

Prima di rispedire al costruttore una pompa per riparazioni o advanced exchange service, è indispensabile compilare e far pervenire al locale ufficio vendite la scheda "Sicurezza e Salute" allegata al presente manuale di istruzioni. Copia della stessa deve essere inserita nell'imballo della pompa prima della spedizione.

Qualora una pompa dovesse essere rottamata, procedere alla sua eliminazione nel rispetto delle normative nazionali specifiche.

ALLGEMEINES

Dieser Apparat ist für Fachbetriebe bestimmt. Vor Gebrauch sollte der Benutzer dieses Handbuch sowie alle weiteren mitgelieferten Zusatzdokumentationen genau lesen. Bei Nichtbeachtung -auch teilweise- der enthaltenen Hinweise, unsachgemäßem Gebrauch durch ungeschultes Personal, nicht autorisierten Eingriffen und Mißachtung der einheimischen, hier zur Geltung kommenden Bestimmungen übernimmt die Firma Varian keinerlei Haftung.

Bei den Pumpen der Serie Turbo-V 70D handelt es sich um Turbomolekularpumpen für Hoch- und Ultrahochvakuumanwendungen. Sie eignen sich für jede Art von Gas oder gashaltige Gemische, nicht jedoch zur Förderung von Flüssigkeiten oder Festpartikel.

Die Pumpwirkung wird durch eine Hochgeschwindigkeitsturbine (max. 75000 Upm) erzielt, die von einem Hochleistungsdrehstrommotor angetrieben wird. Die Turbo-V 70D-Pumpen enthalten keinerlei ungewaltschädliche Substanzen und eignen sich deshalb auch für Anwendungszwecke, die ein "sauberes" Vakuum vorschreiben.

In den folgenden Abschnitten sind alle erforderlichen Informationen für die Sicherheit des Bedieners bei der Anwendung des Geräts aufgeführt. Detaillierte technische Informationen sind im Anhang "Technical Information" enthalten.

In dieser Gebrauchsanleitung werden Sicherheitshinweise folgendermaßen hervorgehoben:



GEFAHR!

Die Gefahrenhinweise lenken die Aufmerksamkeit des Bedieners auf eine spezielle Prozedur oder Praktik, die bei unkorrekter Ausführung schwere Verletzungen hervorrufen können.



ACHTUNG!

Die Warnhinweise vor bestimmten Prozeduren machen den Bediener darauf aufmerksam, daß bei Nichteinhaltung Schäden an der Anlage entstehen können.

ANMERKUNG

Die Anmerkungen enthalten wichtige Informationen, die aus dem Text hervorgehoben werden.

LAGERUNG

Um ein Höchstmaß an Effizienz und Zuverlässigkeit der Varian Turbomolekularpumpen zu gewährleisten, sind die folgenden Anweisungen zu beachten:

- Während des Transports, der Handhabung und der Einlagerung der Pumpen dürfen die folgenden Grenzwerte nicht überschritten werden:
 - Temperatur: von -20 °C bis 70 °C
 - Relative Feuchtigkeit: von 0 bis 95% (nicht kondensierend)
- Der Kunde hat die Turbomolekularpumpen nach dem Empfang bei Erstinbetriebnahme stets im Modus Soft-Start einzusetzen.
- Die Lagerdauer für eine Turbomolekularpumpe beträgt 10 Monate ab dem Speditionsdatum.



ACHTUNG!

Falls die Lagerdauer aus verschiedentlichen Gründen die genannte Frist überschreiten sollte, ist die Pumpe an das Werk zurückzusenden. Für Informationen wenden Sie sich bitte an den örtlichen Varian Vertreter.

VOR DER INSTALLATION

Die Pumpe wird mit einer speziellen Schutzverpackung geliefert. Eventuelle Transportschäden müssen der zuständigen örtlichen Verkaufsstelle gemeldet werden.

Beim Auspacken vorsichtig vorgehen, damit die Pumpe nicht fällt oder Stößen ausgesetzt wird.

Das Verpackungsmaterial muß korrekt entsorgt werden. Es ist vollständig recyclebar und entspricht der EG-Richtlinie 85/399 für Umweltschutz.



ACHTUNG!

Um Entgasungsprobleme zu vermeiden, dürfen die Komponenten, die in Berührung mit dem Vakuum kommen, nicht mit bloßen Händen angefaßt werden. Immer Handschuhe oder einen anderen geeigneten Schutz tragen.

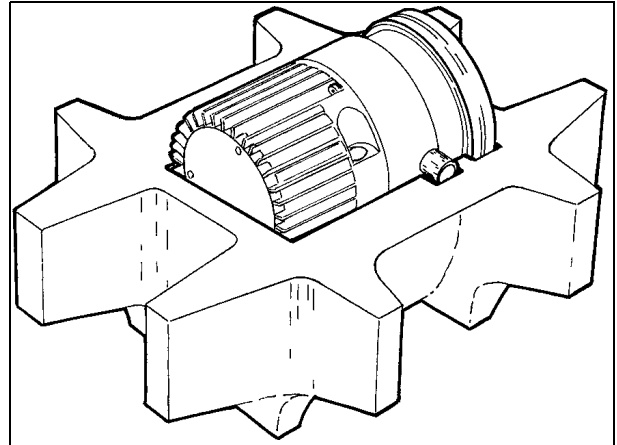

ANMERKUNG

Die Pumpe kann, wenn sie ganz einfach der Atmosphäre ausgesetzt ist, keine Schäden erleiden. Sie sollte jedoch bis zur Installation auf der Anlage geschlossen bleiben, um Staubverschmutzungen zu vermeiden.

INSTALLATION

Die Pumpe darf nicht in Umgebungen benutzt werden, die ungeschützt vor Wetter (Regen, Frost, Schnee), Staub und aggressiven Gasen sind und in denen Explosions- und erhöhte Brandgefahr besteht.

Beim Betrieb müssen folgende Umgebungsbedingungen eingehalten werden:

- Maximaldruck: 2 Bar
- Temperatur: von +5 °C bis +35 °C
- Relative Luftfeuchtigkeit: 0-95% (nicht kondensierend).

Sind Magnetfelder vorhanden, müssen die Pumpen über Einsatz eines entsprechend geeigneten Schutzes geschützt werden.



ACHTUNG!

Entfernen Sie die Klebefolie und den Schutzdeckel erst beim Anschluß der Turbopumpe an die Anlage.

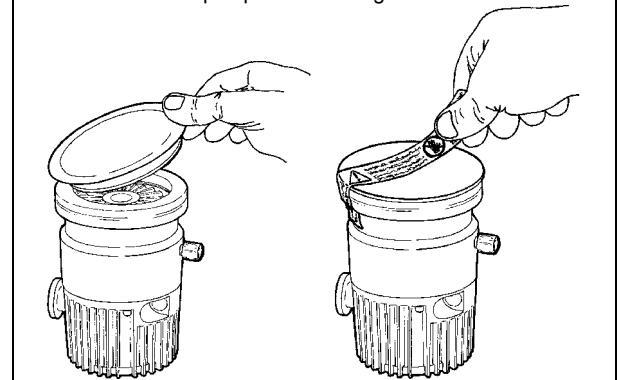

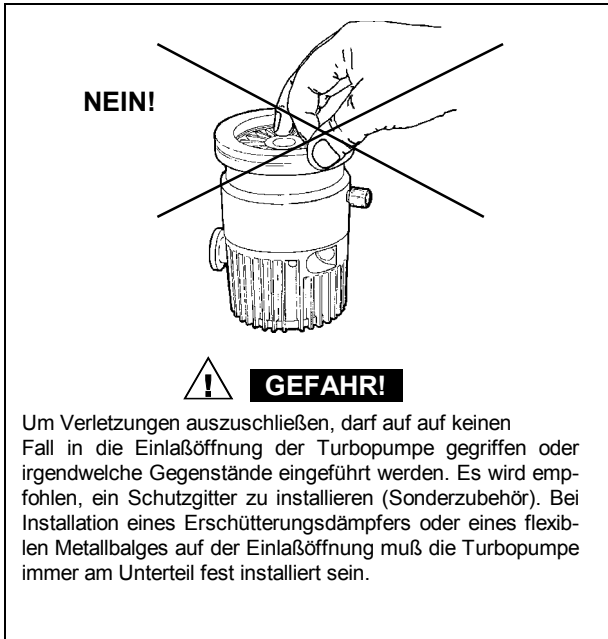

Die Turbomolekularpumpen der Baureihe Turbo-V 70D dürfen ausschließlich mit einer der Varian-Spezialsteuerungen betrieben werden (Baureihen 969-9405, 969-9505, 969-9507 oder 969-9508) und müssen an eine Primärpumpe angeschlossen werden (siehe Schema "Technical Information").

Die Turbopumpen können in jeder Position installiert werden. Befestigen Sie die Turbopumpe in einer stabilen Position, indem Sie den Eingangsflansch der Pumpe an einen festen Gegenflansch anschließen, der um die eigene Achse einem Drehmoment von 200 Nm um seine eigene Achse aushält, oder den als Option erhältlichen Bausatz für die Befestigung am Socketteil benutzen

Turbopumpen mit ISO-Eingangsflansch müssen mittels doppelten oder einfachen Klemmschellen an die Vakuumkammer angeschlossen werden. In der nachstehenden Tabelle sind die Anzahl der jeweils erforderlichen Klemmschellen sowie der jeweilige Anzugsmoment angegeben.

FLANSCH	SCELLENART	ANZAHL	ANZUGSMOMENT
ISO 63	Doppelklemme mit NM10-Gewinde	4	22 Nm
	Einzelklemme mit NM8-Gewinde	4	11 Nm

Turbopumpen mit ConFlat-Eingangsflansch müssen mit dem speziellen Varian-Befestigungsmaterial an die Vakuumkammer angeschlossen werden. Weitere Hinweise siehe Anhang "Technical Information".

Wenn die Pumpen über ihr Unterteil installiert werden sollen, müssen in die Bohrungen des Unterteils 3 M4-Schrauben eingesetzt werden. Die Schrauben müssen eine Dehngrenze von 500N/mm² haben und mit einem Anzugsmoment 0,9 Nm angezogen werden.

Installation Sonderzubehör: siehe Anhang "Technical Information".

ANWENDUNG

Sämtliche Hinweise für den korrekten Betrieb der Turbopumpe sind im Handbuch der Steuereinheit enthalten.

Dieses Handbuch sollte vor der Inbetriebnahme genau gelesen werden.

Um einen optimalen Enddruck zu erhalten, kann das Pumpengehäuse mit einer Heizmanschette (Optional) ausgeheizt werden.

Damit die Flanschgrenztemperatur der Turbopumpe 120°C nicht überschreitet, sollte immer bei ausheizbaren Vakuumsystemen die TP mit Wasserkühlung arbeiten.



GEFAHR!

Während des Ausheizens dürfen weder die Pumpe noch eventuelle heiße Anschlußteile berührt werden, denn es besteht Verbrennungsgefahr.



ACHTUNG!

Für die Belüftung der Pumpe trockene staub- und partikelfreie Luft, oder Edelgase verwenden. Der Eingangsdruck am Belüftungsanschluß muß kleiner als 2 bar sein.



ACHTUNG!

Während des Betriebs sind Stoß- und Vibrationseinwirkungen sowie Ruckbewegungen an der Turbopumpe zu vermeiden, da die Lager beschädigt werden könnten.



ACHTUNG!

Zum Pumpen von aggressiven Gasen dürfen nur Sonderausführungen der Pumpe Turbo-V 70D benutzt werden. Diese Pumpen haben einen Anschluß, durch die ein Edelgasstrom von 0,4 bis 1 mbar ltr/sec fließen muß.

WARTUNG

Die Pumpen der Baureihe Turbo-V 70D sind wartungsfrei. Eventuelle Eingriffe dürfen nur von autorisierten Fachkräften vorgenommen werden.



GEFAHR!

Vor jedem Eingriff an der Turbopumpe den Netzstecker ziehen, die Pumpe über Öffnung des entsprechenden Ventils belüften, warten bis der Rotor vollkommen stillsteht und die Temperatur am Pumpengehäuse unter 50°C abgesunken ist.

Bei einem Defekt kann der Varian Service oder der "advanced exchange service" in Anspruch genommen werden.

ANMERKUNG

Vor dem Versand einer defekten Pumpe an die Fa. Varian muß das Formular "Sicherheit und Gesundheit", das diesem Handbuch beiliegt, ausgefüllt an Varian geschickt und bestätigt werden. Eine Kopie muß den Frachtpapieren beigelegt werden.

Eine eventuelle Verschrottung muß unter Einhaltung der einschlägigen landesüblichen Vorschriften erfolgen.

GENERALITES

Cet appareillage a été conçu en vue d'une utilisation professionnelle. Il est conseillé à l'utilisateur de lire attentivement cette notice d'instructions ainsi que toute autre indication supplémentaire fournie par Varian, avant d'utiliser l'appareil. Varian décline par conséquent toute responsabilité en cas d'inobservation totale ou partielle des instructions données, d'utilisation incorrecte de la part d'un personnel non formé, d'opérations non autorisées ou d'un emploi contraire aux réglementations nationales spécifiques.

Les pompes de la série Turbo-V 70D sont des pompes turbomoléculaires conçues pour des applications de vide poussé et ultra-poussé, capables de pomper n'importe quel type de gaz ou de composé gazeux. Elles ne sont pas indiquées pour le pompage de liquides ou de particules solides.

L'effet de pompage est obtenu grâce à une turbine tournant à vitesse élevée (75000 tr/min maxi), mue par un moteur électrique triphasé à haut rendement. Les pompes Turbo-V 70D sont totalement dépourvues d'agents polluants et sont par conséquent indiquées pour les applications exigeant un vide "propre".

Les paragraphes suivants donnent toutes les indications nécessaires à garantir la sécurité de l'opérateur pendant l'utilisation de l'appareillage. Des renseignements plus détaillés se trouvent dans l'appendice "Technical Information".

Cette notice utilise les signes conventionnels suivants:



DANGER!

Les messages de danger attirent l'attention de l'opérateur sur une procédure ou une manoeuvre spéciale qui, si elle n'est pas effectuée correctement, risque de provoquer de graves lésions.



ATTENTION!

Les messages d'attention apparaissent avant certaines procédures qui, si elles ne sont pas observées, pourraient endommager sérieusement l'appareillage.

NOTE

Les notes contiennent des renseignements importants, isolés du texte.

STOCKAGE

Pour garantir les performances et la fiabilité maximales des pompes turbomoléculaires Varian, il est indispensable de respecter les instructions suivantes :

- Le transport, la manutention et le stockage des pompes, doivent impérativement avoir lieu dans les conditions ambiantes suivantes:
 - température : de -20 °C à +70 °C
 - humidité relative : de 0 à 95% (non condensante)
- A la première utilisation, les pompes turbomoléculaires doivent toujours être mises en marche en mode soft-Start.
- Le temps de stockage d'une pompe turbomoléculaire est de 10 mois à compter de la date d'expédition.



ATTENTION!

En cas de dépassement du temps de stockage, la pompe doit être retournée en usine. Pour tout renseignement, contacter le représentant Varian de zone.

PREPARATION POUR L'INSTALLATION

La pompe est fournie dans un emballage de protection spécial; si l'on constate des marques de dommages pouvant s'être produits pendant le transport, contacter aussitôt le bureau de vente local. Pendant l'opération d'ouverture de l'emballage, veiller tout particulièrement à ne pas laisser tomber la pompe et à ne lui faire subir aucun choc ni aucune vibration.

Ne pas disperser l'emballage dans la nature. Le matériel est entièrement recyclable et il est conforme à la directive CEE 85/399 en matière de protection de l'environnement.



ATTENTION!

En vue d'éviter tous problèmes de dégazage, ne pas toucher, les mains nues, les éléments devant être exposés au vide. Mettre toujours des gants ou toute autre protection appropriée.

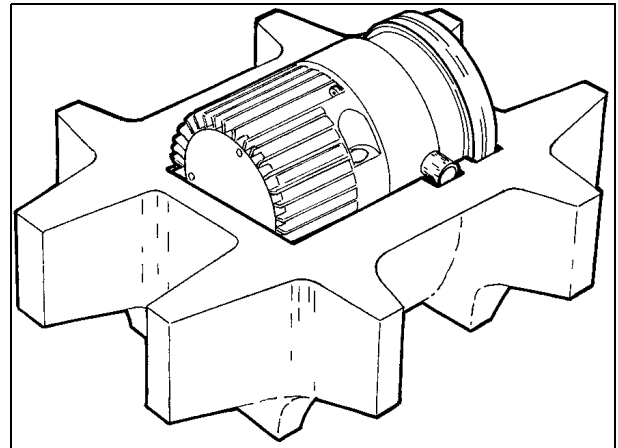

NOTE

La pompe ne peut être endommagée en restant simplement exposée à l'atmosphère. Il est de toute façon conseillé de la garder enfermée jusqu'au moment de l'installation, afin d'éviter toute pollution due à la poussière.

INSTALLATION

Ne pas installer et/ou utiliser la pompe dans des milieux exposés à des agents atmosphériques (pluie, gel, neige), à des poussières, à des gaz de combat ainsi que dans des milieux explosifs ou à risque élevé d'incendie. Pendant le fonctionnement, il est nécessaire de respecter les conditions environnementales suivantes:

- pression maxi: 2 bar
- température: de +5°C° à +35°C
- humidité relative: 0 - 95% (non condensante)

Les pompes turbomoléculaires de la série Turbo-V 70D ne doivent être utilisées qu'avec l'un des contrôleurs spéciaux Varian (série 969-9405, 969-9505, 969-9507 ou 969-9508) et doivent être connectées à une pompe primaire (Cf. schéma dans "Technical Information").



ATTENTION!

N'enlever l'adhésif, puis le couvercle qu'au moment de la connexion de la turbopompe au système.

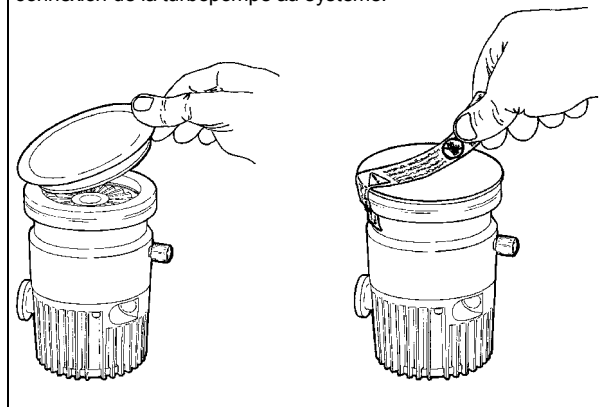

NON!



! DANGER!

Pour éviter toutes lésions à la personne, ne jamais introduire - pour quelque motif que ce soit - les doigts ou bien des objets dans l'entrée de la turbopompe. Il est conseillé d'utiliser un filet de protection (option). Si l'on utilise un amortisseur de vibrations ou bien un soufflet métallique flexible sur l'entrée, fixer toujours la turbopompe à la base.

La turbopompe devra être installée en position verticale ou en position retournée avec une inclinaison maximum de 10° par rapport à l'axe vertical.

La turbopompe peut être installée dans n'importe quelle position. Fixer la turbopompe dans une position stable en reliant la bride d'entrée à une contre-bride fixe pouvant supporter un couple de 200 Nm autour de son axe, ou bien en utilisant le kit en option prévu pour une fixation à la base de la pompe.

La turbopompe à bride d'entrée ISO doit être fixée à la chambre à vide à l'aide de colliers doubles ou simples. Le tableau suivant indique le nombre de colliers nécessaires et le couple de serrage prescrit.

BRIDE	TYPE DE COLLIER	NBRE	COUPLE DE SERRAGE
ISO 63	Collier double à filetage M10	4	22 Nm
	Collier simple à filetage M8	4	11 Nm

La turbopompe à bride d'entrée ConFiat doit être fixée à la chambre à vide à l'aide des éléments mécaniques Varian prévus à cet effet. Pour tout autre détail, se reporter à l'appendice "Technical Information".

Pour fixer la pompe au moyen de sa base, il est nécessaire d'utiliser trois vis M4 fixées aux trous prévus à cet effet se trouvant sur la base de la pompe. Les vis utilisées doivent avoir une limite d'élasticité de 500 N/mm² et être fixées à un couple de 0,9 Nm.

Pour l'installation des accessoires en option, consulter "Technical Information".

UTILISATION

Toutes les instructions pour le fonctionnement correct de la turbopompe sont contenues dans la notice de l'unité de contrôle.

Il est conseillé de lire attentivement cette notice avant d'utiliser la pompe. Pour atteindre de meilleures pressions limite, il est possible de chauffer le carter de la pompe à l'aide du réchauffeur optionnel. Pendant le chauffage éventuel de la chambre à vide, la température de la bride d'entrée ne doit pas dépasser 120°C. Utiliser toujours le refroidissement par eau pendant les opérations de chauffage.

Utiliser toujours le refroidissement par eau pendant les opérations de chauffage.

! DANGER!

Eviter de toucher la turbopompe ainsi que ses accessoires éventuels pendant les opérations de chauffage. La température élevée peut causer des lésions aux personnes.

ATTENTION!

Pour le refoulement de l'air de la pompe, utiliser de l'air ou du gaz inerte exempt de poussière ou de particules. La pression d'entrée à travers la porte prévue à cet effet doit être inférieure à 2 bar.

ATTENTION!

Lorsque la turbopompe fonctionne, éviter tout choc, oscillation ou déplacement brusque car les paliers pourraient se détériorer.

ATTENTION!

Pour le pompage de gaz nocif, utiliser exclusivement les versions spéciales de la pompe Turbo-V70D. Ces pompes sont dotées d'un port ad hoc, à travers laquelle il est nécessaire de fournir à la pompe un flux de gaz inerte compris entre 0,4 et 1 mbar l/s.

ENTRETIEN

Les pompes de la série Turbo-V70D ne requièrent aucun entretien particulier. Toute intervention doit être effectuée par du personnel agréé.

! DANGER!

Avant de procéder à toute opération sur la turbopompe, débrancher le connecteur, refouler l'air de la pompe en ouvrant la soupape prévue à cet effet et attendre jusqu'à l'arrêt complet du rotor et jusqu'à ce que la température superficielle de la pompe soit inférieure à 50°C.

En cas de panne, il est possible de s'adresser au service réparations Varian ou bien au "Varian advanced exchange service" qui permet d'obtenir une pompe régénérée à la place de la pompe détraquée.

NOTE

Avant de renvoyer au constructeur une pompe pour des réparations ou un "advanced exchange service", remplir et faire parvenir au bureau local Varian la fiche "Sécurité et Santé" annexée à la présente notice d'instructions. Une copie de cette fiche devra être mise dans l'emballage de la pompe avant l'expédition.

En cas de mise au rebut de la pompe, procéder à son élimination conformément aux réglementations nationales en la matière.

INFORMACION GENERAL

Este equipo se ha concebido para un uso profesional. El usuario deberá leer atentamente el presente manual de instrucciones y cualquier otra información suplementaria facilitada por Varian antes de utilizar el equipo. Varian se considera libre de cualquier responsabilidad debida al incumplimiento total o parcial de las instrucciones, al uso poco apropiado por parte de personal sin adiestrar, a las intervenciones no autorizadas o al uso que no cumpla con las normas nacionales específicas.

Las bombas de la serie Turbo-V 70D son bombas turbomoleculares para aplicaciones de vacío alto y ultra alto que pueden bombear cualquier tipo de gas o de compuesto gaseoso. No son apropiadas para bombear líquidos o partículas sólidas.

El efecto de bombeo se consigue mediante una turbina rotativa de alta velocidad (75000 r.p.m./min. máx) movida por un motor trifásico de gran rendimiento. Las bombas Turbo-V 70D no llevan ningún tipo de agentes contaminantes y por lo tanto son aptas para aplicaciones que requieren un vacío "limpio".

Los apartados siguientes contienen toda la información necesaria para garantizar la seguridad necesaria del operador al utilizar el aparato. Información más detallada se puede encontrar en el anexo "Technical Information".

Este manual utiliza los símbolos convencionales siguientes:



¡PELIGRO!

Los mensajes de peligro atraen la atención del operador sobre un procedimiento o una operación específica que, al no realizarse correctamente, podría provocar graves lesiones personales.



¡ATENCIÓN!

Los mensajes de atención se visualizan antes de procedimientos que, al no respetarse, podrían provocar daños al equipo.

NOTA

Las notas contienen información importante extraída del texto.

ALMACENAMIENTO

Para garantizar el nivel máximo de funcionalidad y fiabilidad de las bombas turbomoleculares Varian, deberán aplicarse las siguientes instrucciones:

- durante el transporte, desplazamiento y almacenamiento de las bombas no deberán superarse las siguientes condiciones ambientales:
 - temperatura: entre -20°C y 70°C ;
 - humedad relativa: entre 0 y 95 % (no condensante);
- el cliente deberá activar siempre las bombas turbomoleculares en modalidad Soft-Start al recibir las y ponerlas en funcionamiento por primera vez;
- el período máximo de almacenamiento de una bomba turbomolecular es de diez meses a contar de la fecha de envío al cliente.



¡ATENCIÓN!

En caso de superarse por cualquier motivo el período máximo permitido de almacenamiento, será necesario devolver la bomba al fabricante. Para mayores informaciones al respecto, se ruega contactar con el representante local de Varian.

PREPARACION PARA LA INSTALACION

La bomba se suministra en un embalaje de protección dimensional; si se observan señales de daños, que podrían haberse producido durante el transporte, ponerse en contacto con la oficina de venta más cercana.

Durante la operación de desembalaje, prestar una atención especial a no dejar caer la bomba ni someterla a golpes.

No dispersar el embalaje en el medio ambiente. El material es totalmente reciclable y se ajusta a la directiva CEE/399 para la preservación del medio ambiente.



¡ATENCIÓN!

Para evitar la degasificación, no tocar con las manos sin guantes los componentes destinados a someterse al vacío. Utilizar siempre los guantes u otra protección apropiada.

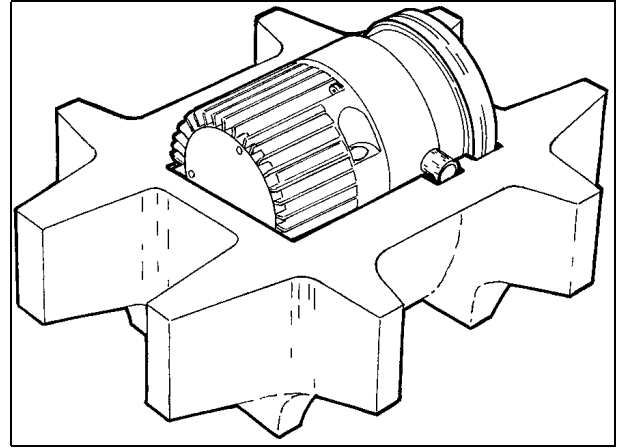

NOTA

La bomba no se puede dañar sólo por quedar expuesta a la atmósfera. De todas formas, se aconseja mantenerla cerrada hasta el momento de la instalación en el sistema para evitar una posible contaminación debida al polvo.

INSTALACION

No instalar ni utilizar la bomba en ambientes expuestos a agentes atmosféricos (lluvia, hielo, nieve), polvos, gases agresivos, en ambientes explosivos o con alto riesgo de incendio.

Durante el funcionamiento es preciso que se respeten las condiciones ambientales siguientes:

- presión máxima: 2 bar
- temperatura: de $+5^{\circ}\text{C}$ a $+35^{\circ}\text{C}$
- humedad relativa: 0 - 95% (no condensadora)

Las bombas turbomoleculares de la serie Turbo-V 70D han de utilizarse exclusivamente con uno de los controladores Varian (serie 969-9405, 969-9505, 969-9507 ó 969-9508) y se conectarán a una bomba primaria (véase esquema en "Technical Information").



¡ATENCIÓN!

Eliminar el adhesivo y quitar el tapón de protección sólo en el momento en que se conecte la turbobomba al sistema.

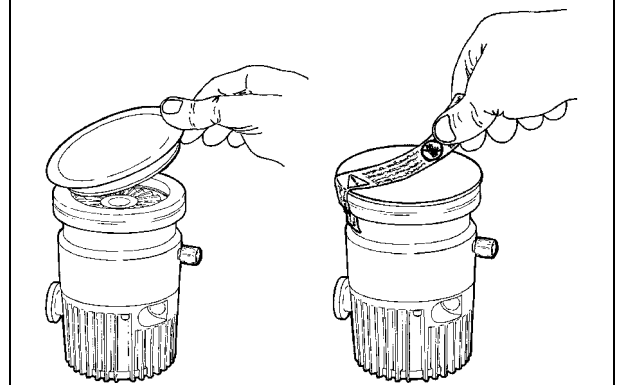



La turbobomba se puede instalar en cualquier posición. Fijar la turbobomba en posición estable uniendo la brida de entrada de la turbobomba con una contrabrida fija capaz de resistir a un par de 200 Nm alrededor de su eje, o utilizando el kit opcional apropiado para la fijación a la base.

La turbobomba con brida de entrada ISO ha de ir fijada a la cámara de vacío mediante mordazas dobles o mordazas individuales. La tabla siguiente describe el número de mordazas necesarias y el par de apriete al que han de apretarse.

BRIDA	TIPO DE MORDAZA	N.	PAR DE APRIETE
ISO 63	Mordaza doble con rosca M10	4	22 Nm
	Mordaza individual con rosca M8	4	11 Nm

La turbobomba con brida de entrada ConFiat se fijará a la cámara de vacío mediante los accesorios mecánicos Varian. Para más detalles véase el anexo "Technical Information".

Para fijar la bomba mediante su base, es necesario utilizar tres tornillos M4 fijados en los orificios correspondientes que se encuentran en la base de la bomba. Los tornillos utilizados han de tener una carga de deformación elástica de 500 N/mm² y han de fijarse a un par de 0,9 Nm.

Para instalar los accesorios opcionales, véase "Technical Information".

UTILIZACION

Todas las instrucciones para el funcionamiento correcto de la turbobomba se encuentran en el manual de la unidad de control. Leer atentamente dicho manual antes de utilizarla.

Para obtener mejores presiones límite, se puede calentar la envoltura de la bomba utilizando el calentador opcional. Durante el posible calentamiento de la cámara de vacío, la temperatura de la brida de entrada no deberá superar 120°C. Utilizar siempre la refrigeración por agua durante las operaciones de calentamiento.



operaciones de calentamiento. La alta temperatura puede provocar lesiones a las personas.



Para el envío de aire de la bomba utilizar aire o gas inerte sin polvo o partículas. La presión de entrada a través de la puerta apropiada deberá ser inferior a 2 bar.



Evítense golpes, oscilaciones o bruscos desplazamientos de la turbobomba durante su funcionamiento. Los cojinetes podrían dañarse.



Para bombear gases agresivos utilizar sólo las versiones especiales de la bomba Turbo - V 70D. Estas bombas van dotadas de una puerta a través de la cual es preciso suministrar a la bomba un caudal de gas inerte comprendido entre 0.4 y 1 mbar l/s.

MANTENIMIENTO

Las bombas de la serie Turbo-V70D no necesitan ningún tipo de mantenimiento. Cualquier operación tendrá que ser realizada por personal autorizado.



Antes de realizar cualquier intervención en la turbobomba, desempalmar el conector de alimentación, enviar aire a la bomba abriendo la válvula apropiada y esperar hasta que el rotor se pare completamente y esperar a que la bomba esté por debajo de 50 °C.

En caso de avería se podrá utilizar el servicio de reparación Varian o el "Varian advanced exchange service", que permite obtener una bomba regenerada para sustituir la averiada.

NOTA

Antes de enviar al fabricante una bomba para su reparación o "advanced exchange service", es imprescindible cumplimentar y remitir a la oficina de Ventas más cercana la ficha de "Seguridad y Salud" adjunta al presente manual de instrucciones. Una copia de la misma se deberá introducir en el embalaje de la bomba antes de enviarla.

En caso de que la bomba se tenga que desguazar, efectuar su eliminación respetando las normas nacionales específicas.

INFORMAÇÕES GERAIS

Esta aparelhagem destina-se ao uso profissional. O utilizador deve ler atentamente o presente manual de instruções e qualquer outra informação adicional fornecida pela Varian antes de usar a aparelhagem. A Varian não se responsabiliza pela eventual inobservância total ou parcial das instruções, pelo uso indevido por parte de pessoas não treinadas, por operações não autorizadas ou pelo uso contrário às normas nacionais específicas.

As bombas da série Turbo-V 70D são bombas turbomoleculares para aplicações de alto e ultra-alto vácuo, capazes de bombear qualquer tipo de gás ou de composto gasoso. Não são adequadas para bombear líquidos ou partículas sólidas.

O efeito da bomba é obtido através de uma turbina rotativa de alta velocidade (75.000 r.p.m. máx.) movida por um motor eléctrico trifásico de alto rendimento. As bombas Turbo-V 70D são totalmente sem agentes contaminadores e, portanto, são adequadas para aplicações que requerem um vácuo "limpo".

Nos parágrafos seguintes estão descritas todas as informações necessárias para garantir a segurança do técnico durante o uso da aparelhagem. Informações detalhadas são fornecidas no apêndice "Technical Information".

Este manual utiliza as seguintes convenções:



PERIGO!

As mensagens de perigo chamam a atenção do técnico para um procedimento ou uma prática específica que, se não efectuada correctamente, poderia provocar graves lesões pessoais.



ATENÇÃO!

As mensagens de atenção são visualizadas antes de procedimentos que, se não observados, poderiam causar danos à aparelhagem.

OBS

As obs. contêm informações importantes destacadas do texto.

ARMAZENAGEM

Para garantir o nível Máximo de funcionalidade e fiabilidade das bombas Turbomoleculares Varian, devem ser observadas as seguintes prescrições:

- durante o transporte, o deslocamento e a armazenagem das bombas as condições ambientais devem ser as seguintes:
 - temperatura: de -20 °C a 70 °C
 - umidade relativa: de 0 a 95% (não condensante)
- ao acionar as bombas turbomoleculares pela primeira vez, o cliente deve ativá-las sempre em modalidade Soft-Start
- o tempo máximo de armazenagem de uma bomba turbomolecular é de 10 meses a contar da data da expedição.



ATENÇÃO!

Se, por uma razão qualquer, o período de armazenagem for superior, será necessário enviar outra vez a bomba para o fabricante. Para mais informações, contactar o representante local da Varian.

PREPARAÇÃO PARA A INSTALAÇÃO

A bomba é fornecida numa embalagem protectora especial; se apresentarem sinais de danos, que poderiam verificar-se durante o transporte, entrar em contacto com o escritório de vendas local. Durante a retirada da embalagem, tomar muito cuidado para não deixar cair a bomba e não submetê-la a colisões ou vibrações. Não depositar a embalagem no meio ambiente. O material é completamente reciclável e responde às normas CEE 85/399 para a protecção do meio ambiente.



ATENÇÃO!

Para evitar problemas de perdas de gás, não tocar com as mãos os componentes destinados à exposição do vácuo. Utilizar sempre luvas ou outra protecção adequada.

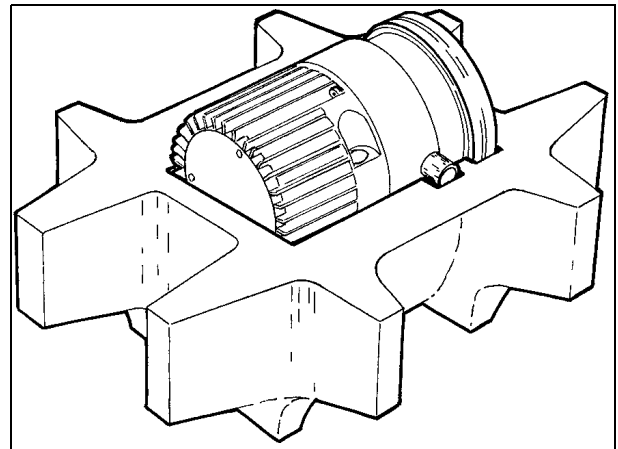

OBS

A bomba não pode ser danificada permanecendo simplesmente exposta à atmosfera. Aconselha-se, no entanto, mantê-la fechada até o momento da instalação no sistema para evitar que se suje com poeiras.

INSTALAÇÃO

Não instalar e/ou usar a bomba em ambientes expostos a agentes atmosféricos (chuva, gelo, neve), poeiras, gases agressivos, em ambientes com possibilidade de explosão ou com elevado risco de incêndio.

Durante o funcionamento é necessário que sejam respeitadas as seguintes condições ambientais:

- pressão máxima: 2 bar
- temperatura: de + 5°C a + 35°C
- humidade relativa: 0 - 95% (não condensante).



ATENÇÃO!

Remover o adesivo e retirar o tampão de protecção só no momento da ligação da turbobomba ao sistema.

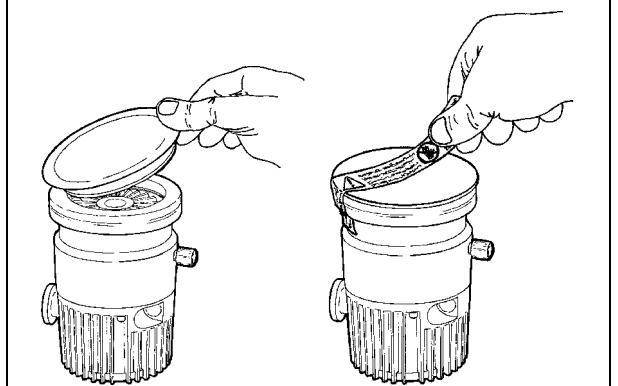

As bombas turbomoleculares da série Turbo-V 70D devem ser utilizadas somente com um dos controladores Varian específicos (série 969-9405, 969-9505, 969-9507 ou 969-9508) e devem ser ligadas a uma bomba primária (ver esquema em "Technical Information").

NÃO!



PERIGO!

Para evitar lesões à pessoa nunca colocar, por qualquer motivo, os dedos ou objectos no bocal de entrada da turbobomba. Aconselha-se o uso da rede de protecção (opcional). Se é utilizado um amortecedor de vibrações ou um respirador metálico flexível no bocal de entrada, fixar sempre a turbobomba à base.

A turbobomba pode ser instalada em qualquer posição. Fixar a turbobomba em posição estável ligando a flange de entrada da turbobomba a uma contraflange fixa capaz de resistir a um torque de 200 Nm ao redor do próprio eixo, ou utilizando o kit específico opcional para a fixação à base.

A turbobomba com flange de entrada ISO, deve ser fixada às câmaras de vácuo através de bornes duplos ou simples. A tabela a seguir descreve o número de bornes necessários e com qual torque devem ser apertados.

FLANGE	TIPO DE BORNE	Nº	TORQUE
ISO 63	Borne duplo com rosca M10	4	22 Nm
	Borne simples com rosca M8	4	11 Nm

A turbobomba com flange de entrada ConFlat deve ser fixada à câmara de vácuo através de parafusos específicos da mecânica Varian. Para maiores detalhes, ver o apêndice "Technical Information".

Para fixar a bomba através da sua base, é necessário utilizar três parafusos M4 fixados aos furos específicos existentes na base da bomba. Os parafusos utilizados devem possuir um limite de carga de 500 N/mm² e devem ser fixados com um binário de 0,9 Nm.

Para a instalação dos acessórios opcionais, ver "Technical Information".

UTILIZAÇÃO

Todas as instruções para o correcto funcionamento da turbobomba estão contidas no manual da unidade de controlo. Ler atentamente este manual antes da utilização.

Para atingir melhores pressões limite é possível aquecer o invólucro da bomba utilizando o aquecedor opcional. Durante o eventual aquecimento da câmara a vácuo, a temperatura no flange de entrada não deve ser superior a 120 °C. Utilizar sempre o resfriamento com água durante as operações de aquecimento. Utilizar sempre o resfriamento com água durante as operações de aquecimento.



PERIGO!

Não tocar a turbobomba e os seus eventuais acessórios durante as operações de aquecimento. A elevada temperatura pode causar lesões às pessoas.



ATENÇÃO!

Para a saída de ar da bomba utilizar ar ou gás inerte sem poeiras ou partículas. A pressão de entrada através da porta específica deve ser inferior a 2 bar.



ATENÇÃO!

Evitar colisões, oscilações ou deslocamentos bruscos da turbobomba quando está a funcionar. Os rolamentos poderiam sofrer danos.



ATENÇÃO!

Para bombear gases agressivos utilizar só as versões especiais da bomba Turbo - V 70D. Estas bombas estão equipadas com uma porta específica através da qual é necessário fornecer à bomba um fluxo de gás inerte entre 0.4 e 1 mbar l/s.

MANUTENÇÃO

As bombas da série Turbo-V70D não requerem qualquer manutenção. Qualquer operação deve ser efectuada por pessoal autorizado.



PERIGO!

Antes de efectuar qualquer operação na turbobomba desligar o conector de alimentação, introduzir ar na bomba abrindo a válvula específica, aguardar até a completa paragem do rotor e até que a temperatura superficial da bomba seja inferior a 50°C.

Em caso de defeito é possível usufruir do serviço de reparação Varian ou do "Varian advanced exchange service", que permite obter uma bomba regenerada que substitua a bomba com defeito.

OBS.

Antes de enviar ao construtor uma bomba para reparações ou advanced exchange service, é indispensável preencher e enviar ao escritório local de vendas a ficha "Segurança e Saúde" anexa ao presente manual de instruções. A cópia da mesma deve ser colocada na embalagem da bomba antes da expedição.

Caso uma bomba deva ser destruída, proceder à sua eliminação respeitando as normas nacionais específicas.

ALGEMENE INFORMATIE

Deze apparatuur is bestemd voor beroepsmatig gebruik. De gebruiker wordt verzocht aandachtig deze handleiding en alle overige door Varian verstrekte informatie door te lezen alvorens het apparaat in gebruik te nemen. Varian acht zich niet aansprakelijk voor de gevolgen van het niet of gedeeltelijk in acht nemen van de aanwijzingen, onoordeelkundig gebruik door niet hiervoor opgeleid personeel, reparaties waarvoor geen toestemming is verkregen of gebruik in strijd met de specifieke nationale wetgeving.

De pompen van de serie Turbo-V 70D zijn turbomoleculaire pompen voor hoge en ultrahoge vacuümtoepassingen, die in staat zijn om elk type gas of gasverbinding te pompen. Ze zijn niet geschikt voor het pompen van vloeistoffen of vaste deeltjes.

Het pompeffect wordt verkregen door een zeer snel draaiende turbine (max. 75.000 toeren/min.) die aangedreven wordt door een elektrische draaistroommotor met hoog rendement. De Turbo-V 70D pompen zijn volledig vrij van verontreinigingen en zijn dus ook geschikt voor toepassingen die een "schoon vacuüm" verlangen. In de volgende paragrafen is alle informatie vermeld om de veiligheid van de operator tijdens het gebruik van de apparatuur te verzekeren. Gedetailleerde informatie is te vinden in de bijlage "Technical information".

Deze handleiding gebruikt de volgende symbolen:



Bij dit symbool staat tekst die de aandacht van de operator vestigt op een speciale procedure of methode die, indien niet correct uitgevoerd, ernstig lichamelijk letsel kan veroorzaken.



Bij dit symbool staat tekst met procedures die, indien niet opgevolgd, schade aan apparatuur kunnen veroorzaken.

OPMERKING

De opmerkingen bevatten belangrijke informatie die uit de tekst is gelicht.

OPSLAG

Om een zo goed mogelijke werking en betrouwbaarheid van de Turbomoleculaire pompen van Varian te garanderen, moeten de volgende voorschriften in acht worden genomen:

- tijdens transport, verplaatsing en opslag van de pompen moet aan de volgende omgevingscondities worden voldaan:
 - temperatuur: van -20 °C tot 70 °C
 - relatieve vochtigheid: van 0 tot 95% (niet condenserend)
- de klant moet de turbomoleculaire pompen altijd met de Soft-Start opstarten wanneer ze ontvangen worden en voor de eerste keer in werking worden gesteld
- de opslagtijd van een turbomoleculaire pomp bedraagt 10 maanden vanaf de verzenddatum.



Indien om een willekeurige reden de opslagtijd langer is, moet de pomp weer naar de fabriek worden gestuurd. Voor meer informatie wordt verzocht contact op te nemen met de plaatselijke vertegenwoordiger van Varian.

UITPAKKEN

De pomp wordt in een speciale beschermende verpakking geleverd; als er schade wordt geconstateerd die tijdens het transport veroorzaakt zou kunnen zijn, meteen contact opnemen met het plaatselijke verkoopkantoor.

Zorg er bij het uitpakken voor dat de pomp niet kan vallen of stoten te verduren krijgt.

Laat de verpakking niet ergens buiten achter. Het verpakkingsmateriaal is volledig recyclebaar en voldoet aan de EEG milieurichtlijn 85/399.



Om ontgassingsproblemen te voorkomen, mogen de componenten die met het vacuüm in aanraking komen niet met de blote handen aangeraakt worden. Gebruik altijd wanten of een andere geschikte bescherming.

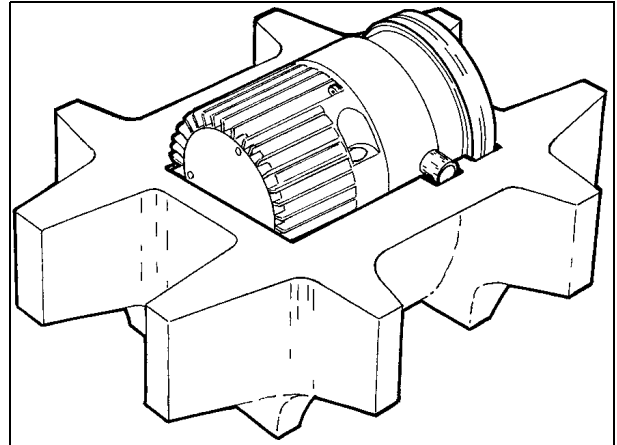

OPMERKING

De pomp kan niet beschadigd worden door eenvoudigweg aan de atmosfeer blootgesteld te worden. Toch wordt aangeraden om de pomp gesloten te houden zolang deze niet in het systeem wordt ingebouwd, zodat eventuele vervuiling door stof wordt voorkomen.

INSTALLATIE

De pomp mag niet geïnstalleerd en/of gebruikt worden in ruimten die blootgesteld zijn aan de weersomstandigheden (regen, vorst, sneeuw), stof, agressieve gassen, of in ruimten met explosiegevaar of zeer hoog brandgevaar.

Tijdens de werking moeten de volgende omgevingscondities aanwezig zijn:

- max. druk: 2 bar
- temperatuur: van +5°C tot +35°C
- relatieve vochtigheid: 0 - 95% (niet condenserend).



Alleen op het moment waarop de turbopomp op het systeem wordt aangesloten mogen de sticker en de beschermdop verwijderd worden.

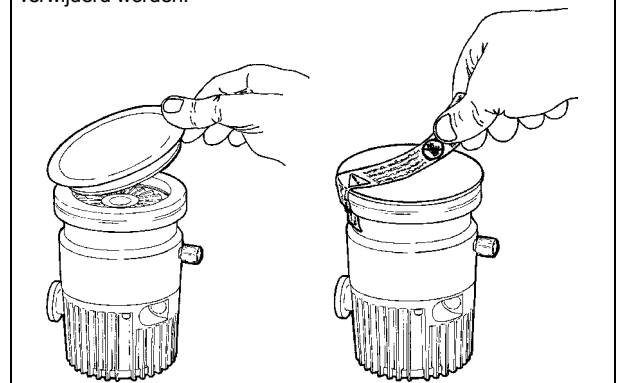

De turbomoleculaire pompen van de serie Turbo-V 70D mogen alleen gebruikt worden in combinatie met een van de speciale Varian controllers (serie 969-9405, 969-9505, 969-9507, of 969-9508) en moeten aangesloten zijn op een primaire pomp (zie schema in "Technical Information").

NEE!



GEVAAR!

Om persoonlijk letsel te voorkomen mogen nooit, om geen enkele reden, de vingers of voorwerpen in de inlaatopening van de turbopomp worden gestoken. Men raadt gebruik van het beschermgaasje aan (optional). Als een trillingdemper of een metalen flexibel balgje op de inlaatopening wordt aangebracht, de turbopomp altijd aan de basis bevestigen.

De turbopomp kan in alle standen worden geïnstalleerd. Bevestig de turbopomp in een stabiele positie en verbind de inlaatflens van de turbopomp met een vaste contraflens die een koppel van 200 Nm rondom de eigen as kan verdragen, of gebruik het speciale optie-pakket voor bevestiging aan de basis.

De turbopomp met ISO inlaatflens moet aan de vacuümkamer worden verbonden met behulp van dubbele of enkelvoudige klemmen. De volgende tabel beschrijft het aantal benodigde klemmen en het aanhaalkoppel waarmee ze vastgezet moeten worden.

FLENS	KLEMTYPE	NR.	AANHAALKOPPEL
ISO 63	Dubbele klem met M10 schroefdraad	4	22 Nm
	Enkelvoudige klem met M8 schroefdraad	4	11 Nm

De turbopomp met ConFlat inlaatflens moet aan de vacuümkamer worden bevestigd met behulp van de speciale mechanische bevestigingselementen van Varian. Zie voor meer informatie de bijlage "Technical Information".

Om de pomp met behulp van zijn basis te bevestigen, zijn drie M4 bouten nodig die in de gaten in de basis van de pomp worden ingebracht. Deze bouten moeten een vloeisterkte van 500 N/mm² bezitten en met een koppel van 0,9 Nm worden aangehaald.

Zie "Technical Information" voor installatie van accessoires die als optie verkrijgbaar zijn.

GEBRUIK

Alle aanwijzingen voor de correcte werking van de turbopomp zijn in de handleiding van de regeleenheid vermeld.

Lees aandachtig deze handleiding vóór ingebruikname door.

Om een betere grensdruk te bereiken, kan het pomphuis verwarmd worden met behulp van een optionele verwarmingsunit. Tijdens de eventuele verwarming van de vacuümkamer mag de temperatuur op de inlaatflens niet meer dan 120° C bedragen.

Pas tijdens het verwarmen altijd waterkoeling toe.

GEVAAR!

Raak de pomp en eventuele accessoires niet tijdens het verwarmen aan. De hoge temperatuur kan lichamelijk letsel veroorzaken.

ATTENTIE!

Gebruik voor de luchttoevoer naar de pomp lucht of inert gas zonder stof of vaste deeltjes. De inlaatdruk via de hiervoor bestemde poort moet minder dan 2 bar (boven de atmosferische druk) bedragen.

ATTENTIE!

Vermijd schokken, trillingen of bruuske verplaatsingen van de turbopomp wanneer deze in werking is. De lagers kunnen anders beschadigd raken.

ATTENTIE!

Gebruik voor het pompen van agressieve gassen alleen de speciale uitvoeringen van de Turbo-V70D pomp. Deze pompen zijn voorzien van een speciale poort, waardoor een stroom inert gas moet worden geleverd die varieert tussen 0.4 en 1 mbar lt/s.

ONDERHOUD

De pompen van de serie Turbo-V70D zijn onderhoudsvrij. Eventuele werkzaamheden moeten door bevoegd personeel worden uitgevoerd.

GEVAAR!

Alvorens werkzaamheden aan de turbopomp uit te voeren, de stekker verwijderen, de pomp met behulp van de hiervoor bestemde klep ontluichten en wachten totdat de rotor volledig stil staat en de oppervlaktetemperatuur van de pomp onder een temperatuur van 50 °C is gezakt.

In geval van storing is het mogelijk om de reparatiedienst van Varian of de "Varian advanced exchange service" in te schakelen: zo krijgt men een ruilpomp ter vervanging van de defecte pomp.

OPMERKING

Alvorens de pomp ter reparatie of ruil naar de fabrikant op te sturen, moet de bij deze handleiding gevoegde kaart "Veiligheid en Gezondheid" volledig ingevuld naar het plaatselijke verkoopkantoor worden gestuurd. Een kopie van deze kaart moet vóór versturing bij de pomp in de verpakking worden gevoegd.

Mocht de pomp gesloopt worden, ga dan overeenkomstig de specifieke nationale wetgeving te werk.

ALMENE OPLYSNINGER

Dette materiel er beregnet til professionel anvendelse. Brugeren bedes læse denne håndbog samt enhver yderligere vejledning. Varian har leveret, inden udstyret tages i brug. Varian er ikke ansvarlig, hvis vejledningen ikke er nøje fulgt, eller hvis den kun er delvist fulgt, og heller ikke hvis udstyret anvendes forkert af ukvalificeret personale, hvis der foretages uautoriserede indgreb på det, eller hvis udstyret benyttes på en måde, der står i kontrast til det pågældende lands særlige normer.

Turbo-V 70D serien omfatter turbomolekulære pumper til højvakuum og til ultra-højvakuum, der er i stand til at pumpe alle typer luftarter og luftforeninger. Denne serie er ikke egnet til at pumpe væsker eller faste partikler.

Pumpeeffekten opnås ved hjælp af en turbine, der roterer ved høj hastighed (max. 75000 omdr./min.) drevet af en højeffektiv trefaset elektrisk motor. Turbo-V 70D pumperne er fuldstændig fri for forurenende stoffer og finder derfor god anvendelse, når der kræves et "rent" vakuum.

I det følgende gives alle nødvendige oplysninger for operatørens sikkerhed under brug af udstyret. For detaljerede oplysninger henvises til den vedlagte "Technical Information".

I denne håndbog findes følgende regler:



ADVARSEL!

Advarslerne henkalder operatørens opmærksomhed på et indgreb eller en særlig handling, der kan forårsage alvorlig fare for kvæstelser, hvis den ikke udføres korrekt.



PAS PÅ

Disse ord forekommer inden en arbejdsmetode, der skal overholdes for ikke at skabe risiko for skade på udstyret.

BEMÆRK

Bemærkningerne indeholder vigtige yderligere oplysninger.

OPBEVARING

Det er nødvendigt at overholde følgende forskrifter for at sikre optimal funktion og driftssikkerhed i de turbomolekylære pumper fra Varian:

- Sørg for, at omgivelserne opfylder følgende betingelser i forbindelse med transport, flytning og opbevaring af pumperne:
 - temperatur: fra -20°C til $+70^{\circ}\text{C}$,
 - relativ fugtighed: fra 0 til 95% (ikke kondenserende).
- Kunden skal altid starte de turbomolekylære pumper ved hjælp af Soft-Start funktionen ved modtagelse og start af pumperne for første gang.
- De turbomolekylære pumper må opbevares i 10 måneder fra forsendelsesdatoen.



VIGTIGT!

Hvis opbevaringsperioden af en eller anden grund er længere, er det nødvendigt at sende pumperne tilbage til fabrikken. Yderligere oplysninger fås ved henvendelse til den lokale Varian repræsentant.

FORBEREDELSE TIL MONTERING

Pumpen leveres med en særlig beskyttelsesemballage. Kontakt vores lokale salgskontor, hvis der findes tegn på beskadigelse, der kan være sket under transporten.

Pas på at pumperne ikke falder på gulvet og at der ikke stødes til den under udpakningen.

Smid ikke emballagen væk ude i naturen. Al emballage er genbrugsmateriale i overensstemmelse med EF-direktiv 85/399 vedrørende miljøbeskyttelse.



PAS PÅ

For at undgå afgangsproblemer skal man ikke røre med de bare hænder de dele, der vil blive udsat for vakuum. Brug altid handsker eller anden passende beskyttelse.

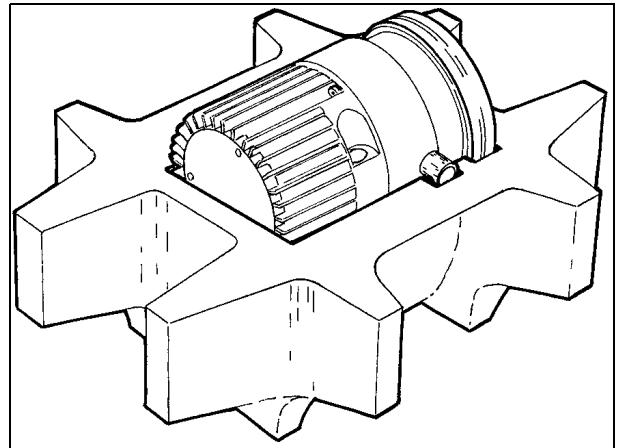

BEMÆRK

Pumpen kan ikke beskadiges ved blot at være udsat for den atmosfæriske luft. For at undgå forurening fra støv anbefales det dog, at pumpen holdes tilpakket, indtil den monteres i anlægget.

MONTERING

Pumpen må ikke installeres eller bruges i omgivelser, der udsætter den for forvitring (regn, frost, sne), støv, ætsende luftarter, og heller ikke i omgivelser med eksplosionsfare eller stor brandfare.

Følgende betingelser skal overholdes under driften:

- maksimaltryk: 2 bar
- temperatur: fra $+5^{\circ}\text{C}$ til $+35^{\circ}\text{C}$
- relativ fugtighed: 0 - 95% (ikke kondenserende).

Turbomolekylærpumperne i V 70D serien må kun anvendes med en af de særlige Varian kontrolapparater (serie 969-9405, 969-9505, 969-9507 eller 969-9508) og skal forbindes med en primær pumpe (se skemaet i "Technical Information").



PAS PÅ

Etiketten og beskyttelsesdækslet fjernes først i det øjeblik, turbopumpen tilsluttes anlægget.

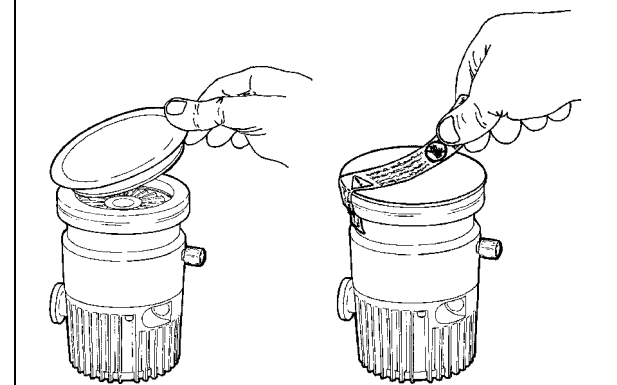



Turbopumpen kan monteres i hvilken som helst stilling. Den fastspændes ved, at turbopumpens indgangsflange fastgøres til en fast modflange, der er i stand til at modstå et drejningsmoment på 200 Nm omkring aksen. Pumpen kan også fastspændes ved hjælp af det særlige udstyr, der fås på efterspørgsel. Turbopumperne med ISO indløbsflange skal fastspændes til vakuumkammeret med dobbelte eller enkelte klemmer. Følgende tabel angiver det nødvendige antal af klemmer og det anvendte tilspændingsmoment for de enkelte flangedimensioner og typer af klemmer.

FLANGE	KLEMMETYPE	ANTAL	TILSPÆNDINGSMOMENT
ISO 63	Dobbelt klemme, gevind M10	4	22 Nm
	Enkelt klemme, gevind M8	4	11 Nm

Turbopumpen med indløbsflange ConFlat skal fastspændes til vakuumkammeret ved hjælp af de specielle fastgørelsesdele fra Varian. For detaljer henvises til "Teknisk information". For at fastspænde pumpen til fundamentet er det nødvendigt at anvende tre M4-skruer, som indsættes i hullerne på pumpens fundament. Skrueerne skal klare en belastning på 500 N/mm² skruernes korrekte tilspændingsmoment er 0,9 Nm. Se "Technical Information" for montering af optionals.

ANVENDELSE

Al vejledning angående turbopumpens korrekte drift er beskrevet i håndbogen til kontrolenheden. Læs den nævnte håndbog omhyggeligt før brugen. For at opnå bedre grænsetryk kan pumpebeklædningen opvarmes. Hvis vakuumkammeret opvarmes, må temperaturen på indgangsflangen ikke overstige 120°C. Brug altid vandafkøling under opvarmningen.

ADVARSEL!

Rør ikke ved turbopumpen eller eventuelt tilbehør under opvarmningsmanøvrerne. Den høje temperatur kan forårsage kvæstelser på personer.

PAS PÅ

Til pumpens luftfløb anvendes luft eller en inaktiv luftart, der er fri for støv og partikler. Indgangstrykket gennem den særlige åbning skal være under 2 bar.

PAS PÅ

Undgå sammenstød, vibrationer eller bratte bevægelser i forbindelse med brug af turbopumpen. Der er risiko for beskadigelse af lejerne.

PAS PÅ

Brug kun specialpumperne af Turbo - V 70D typen til pumpning af ætsende luftarter. Disse pumper er forsynede med en særlig åbning, gennem hvilken den passive luftarts strømning skal ligge mellem 0.4 og 1 mbar l/s.

VEDLIGEHOLDELSE

Pumperne af TURBO-V 70D typen behøver ikke nogen vedligeholdelse. Ethvert indgreb på pumpen skal foretages af autoriseret personale.

ADVARSEL!

Inden der foretages noget som helst indgreb på turbopumpen, skal strømmen først afbrydes og luften lukkes ud af pumpen ved, at man åbner den særlige ventil og venter indtil rotoren er standset helt, og pumpeoverfladetemperatur er lavere end 50°C.

Hvis pumpen går i stykker, kan man benytte sig af Varians reparationservice eller af Varians "Advanced Exchange Service", hvorved man kan få en repareret pumpe i bytte for den, der er gået i stykker.

BEMÆRK

Inden pumpen sendes tilbage til fabrikanten til reparation eller til "Advanced Exchange Service", skal man udfylde formularen "Sikkerhed og Helbred" vedlagt denne håndbog og tilsende den til den lokale forhandler. En kopi af formularen skal vedlægges i pakken med pumpen ved tilbagesendelsen.

Hvis en pumpe skal skrottes, skal dette foregå i overensstemmelse med det pågældende lands særlige love.

ALLMÄN INFORMATION

Utrustningen är avsedd för yrkesmässig användning. Användaren bör läsa denna bruksanvisning, samt övrig dokumentation från Varian före användning av utrustningen. Varian tar inget ansvar för skador helt eller delvis till följd av åsidosättande av instruktionerna, olämplig användning av person utan tillräcklig kunskap, obehörigt bruk av utrustningen eller hantering som strider mot gällande lokala föreskrifter.

Pumparna i Turbo-V 70D -serien är turbomolekylära pumpar för höga och mycket höga vakuumtillämpningar. De kan användas för pumpning av alla typer av gas eller gasföreningar. De lämpar sig inte för pumpning av vätskor eller fasta partiklar.

Pumpningen åstadkoms med hjälp av en högvarv turbin (max 75000 varv/minut) som drivs av en trefas högeffektmotor. Inga tillsatssämnen används i Turbo-V 70D-seriens pumpar, som därför passar för tillämpningar som kräver ett "rent" vakuum.

De följande avsnitten innehåller all information som behövs för att garantera operatörens säkerhet under användningen. Detaljerade uppgifter finns i bilagan "Technical information".

I bruksanvisningen används följande standardrubriker:



VARNING!

Varningsmeddelandena informerar operatören om att en speciell procedur eller en viss typ av arbete måste utföras exakt enligt anvisningarna. I annat fall finns risk för svåra personskador.



VIKTIGT

Detta varningsmeddelande visas framför procedurer som måste följas exakt för att inte risk för maskinskada skall uppstå.

OBSERVERA

Detta visar på viktig information i texten.

FÖRVARING

Respektera följande anvisningar för att garantera optimal prestanda och driftsäkerhet för Varian turbomolekylära pumpar:

- Vid transport, flytt och lagring av pumparna ska följande omgivningsförhållanden respekteras:
 - Temperaturområde: -20 °C till +70 °C.
 - Relativ fuktighet: 0 till 95 % (utan kondens).
- Kunden ska alltid mjukstarta de turbomolekylära pumparna när de mottas och sätts i drift för första gången.
- De turbomolekylära pumparna kan lagras i 10 månader från leveransdatumet.



VIKTIGT !

Om lagringstiden av någon anledning är längre måste pumpen skickas tillbaka till fabriken. Var god och kontakta den lokala Varian-återförsäljaren för ytterligare information.

FÖRBEREDELSE FÖR INSTALLATIONEN

Pumpen levereras i ett särskilt skyddande emballage. Kontakta det lokala försäljningskontoret om emballaget visar tecken på skador som kan ha uppstått under transporten.

Se till att pumpen inte tappas eller utsätts för stötar vid upppackningen.

Kasta inte packmaterialet i soporna. Materialet är återvinningsbart till 100% och uppfyller EU-direktiv 85/399 om miljöskydd.



VIKTIGT

Komponenter som skall utsättas för vakuum får inte hanteras med bara händer p g a kontamineringsrisken. Använd alltid handskar eller liknande skydd.

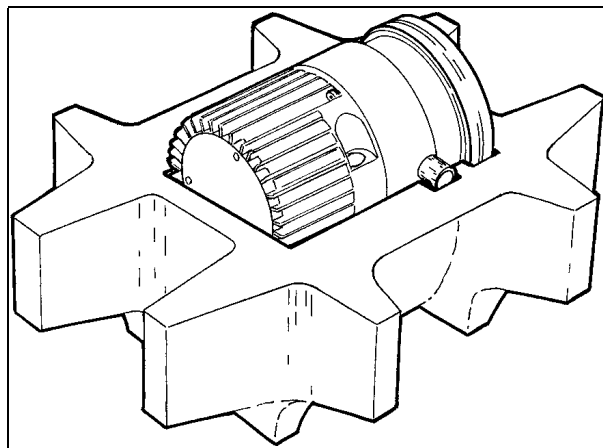

OBSERVERA

Normal påverkan från omgivningen kan inte skada pumpen. Trots det är det säkrast att hålla den stängd tills den har installerats i systemet, för att förhindra att det kommer in damm eller annat i den.

INSTALLATION

Installera inte pumpen i miljöer som utsätts för påverkan från atmosfären (regn, snö, is), damm, aggressiva gaser, och inte heller i explosiv eller brandfarlig miljö.

Följande krav på omgivningsförhållanden gäller vid drift:

- maximitryck: 2 bar
- temperatur: från +5 °C till +35 °C
- relativ luftfuktighet: 0 - 95% (utan kondens)

Turbomolekylärpumparna i serien V 70D måste användas med en särskild styrenhet från Varian (serie 969-9405, 969-9505, 969-9507- eller 969-9508), och anslutas till en förpump (se schema i "Technical information").



VIKTIGT

Ta inte bort tejpens och skyddskåpan innan turbopumpen har anslutits till systemet.

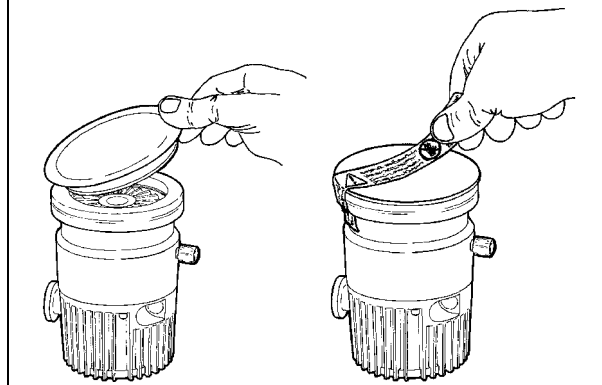

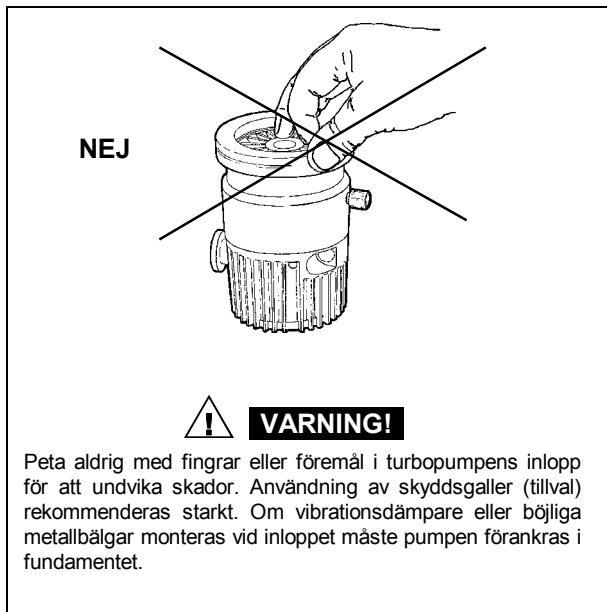

Turbopumpen kan installeras i valfri position. Fäst turbopumpen i ett stabilt läge genom att ansluta pumpens intagsfläns till en fast fläns som måste tåla ett vridmoment på 200 Nm runt den genomgående axeln, eller använd den särskilda monteringsatsen som finns som tillval.

Turbopumpen med ISO-intagsfläns ska fästas i vakuumpkammaren med hjälp av dubbla eller enkla klamrar. Den följande tabellen beskriver nödvändigt antal klamrar och med vilket åtdragningsmoment de ska spännas.

FLÄNS	TYP AV KLAMMER	ANTAL	ÅTDRAGNINGSMOMENT
ISO 63	Dubbel klammer med gänga M10	4	22 Nm
	Enkel klammer med gänga M8	4	11 Nm

Turbopumparna med intagsfläns ConFlat ska fästas till vakuumpkammaren med hjälp av Varian fästdelar. För detaljer hänvisas till bilaga "Technical Information".

För att fästa pumpen till fundamentet är det nödvändigt att använda 3 M4 skruvar, som installeras i hålen på pumpens fundament. De använda skruvarna måste tåla en belastning på 500 N/mm² korrekt åtdragningsmoment är 0,9 Nm.

Installation av tillbehörsutrustning beskrivs i "Technical Information".

ANVÄNDNING

Anvisningar för riktig användning av turbopumpen finns i styrenhetens bruksanvisning.

Läs bruksanvisningen noga innan du startar pumpen.

För att förbättra tryckgränserna kan pumphuset värmas med ett särskilt värmeaggregat som finns som tillval. Under uppvärmningen av pumploppet får temperaturen vid inloppet aldrig bli högre än 120 °C.

Under uppvärmningen måste vattenkyllningen användas.



VARNING!

Vidrör inte turbopumpen eller några tillbehör under uppvärmningen för att undvika brännskador.



VIKTIGT

Använd luft eller ädelgas, fri från damm och partiklar för luftning av pumpen. Trycket vid inloppet får vara högst 2 bar.



VIKTIGT

Undvik sammanstötningar, svängningar eller plötsliga förflyttningar av turbopumpen när den är igång. Lagren kan bli skadade.



VIKTIGT

Vid pumpning av aggressiva gaser skall den specialkonstruerade versionen av Turbo - V 70D pumpen användas. Denna pumptyp är försedd med ett specialuttag dit ett ädelgasflöde mellan 0.4 och 1 mbar l/s skall anslutas.

UNDERHÅLL

Pumparna i Turbo-V 70D-serien är underhållsfria. Allt servicearbete måste utföras av auktoriserad personal.



VARNING!

Innan något arbete utförs på turbopumpen måste pumpens strömförsörjning brytas och pumpen luftas genom att den aktuella ventilen öppnas. Vänta sedan tills rotorn stannat samt tills pumpens ytemperatur är lägre än 50°C.

Om pumpen havererar, kontakta Varian reparationsverkstad eller Varian utbytesservice, som kan ersätta pumpen med en renoverad pump.

OBSERVERA

Innan pumpen lämnas in till tillverkaren för reparation eller utbyte mot en renoverad enhet, måste "hälso- och säkerhetsbladet" som medföljer bruksanvisningen fyllas i och skickas in till den lokala återförsäljaren. Bifoga dessutom en kopia av bladet med pumpen.

Skrotning av pumpen skall ske enligt gällande lagstiftning

GENERELL INFORMASJON

Dette utstyret er beregnet til bruk av profesjonelle brukere. Brukeren bør lese denne brukerveiledningen og all annen informasjon fra Varian før utstyret tas i bruk. Varian kan ikke holdes ansvarlig for hendelser som skjer på grunn av manglende oppfølging av disse instruksjonene, selv delvis, feilaktig bruk av utrent personell, ikke autoriserte endringer av utstyret eller handlinger som på noen måte er i strid med nasjonale bestemmelser.

Turbo-V 70D serien med pumper er turbo-molekulære pumper for bruk i høy- eller ultrahøye vakuumanlegg, og kan pumpe nesten alle typer gass eller gassforening. De er ikke beregnet for å pumpe væsker eller faste partikler.

Pumpingen oppnås med en høyhastighetsturbin (maks. 75000 rpm) koplet til en trefaset elektrisk motor. Turbo-V 70D pumper har ingen forurensende stoffer og er derfor egnet for anlegg med behov for "rene" vakuu.

De følgende avsnitt inneholder all informasjon som er nødvendig for å sikre brukeren når utstyret er i bruk. For mer detaljert bruk vises det til tilleggset "Teknisk informasjon".

Denne manualen bruker følgende standardprotokoll:



ADVARSEL!

Disse meldingene skal tiltrekke seg brukerens oppmerksomhet til en spesiell fremgangsmåte eller praksis som, hvis den ikke følges, kan medføre alvorlige skader.



FORSIKTIG

Denne advarselen vises foran fremgangsmåter som, dersom de ikke følges, kan føre til at utstyret skades.

MERK

Merknadene inneholder viktig informasjon som er hentet fra teksten.

LAGRING

For å garantere optimal drift og pålitelighet for Varian turbomolekulære pumper må følgende anvisninger følges:

- Under transport, flytting og lagring av pumpene må ikke følgende miljøforhold overstiges:
 - Temperatur: fra -20°C til 70°C .
 - Relativ fuktighet: fra 0 til 95% (uten kondensering).
- Kunden må alltid soft-starte de turbomolekulære pumpene når de mottas og startes opp første gang.
- Lagringstiden for en turbomolekulær pumpe er 10 måneder fra sendedato.



FORSIKTIG!

Hvis lagringstiden av en hvilken som helst grunn er lenger må pumpen returneres til fabrikk. Vennligst kontakt den lokale Varian-forhandleren for informasjon.

KLARGJØRE TIL INSTALLASJON

Pumpen leveres i en spesiell beskyttelsesemballasje. Viser denne tegn på skader som kan ha oppstått under transporten, må du ta kontakt med det lokale salgskontoret.

Når pumpen pakkes ut, må du se til at den ikke slippes ned eller utsettes for noen form for støt.

Emballasjen må ikke kastes på en ulovlig måte. Alle materialer er 100% resirkulerbare og er i samsvar med EU-direktiv 85/399 om miljøbeskyttelse.



FORSIKTIG

For å unngå avgassingsproblemer, må ingen del som skal utsettes for vakuu håndteres med bare hendene. Bruk alltid hansker eller andre og passende verneutstyr.

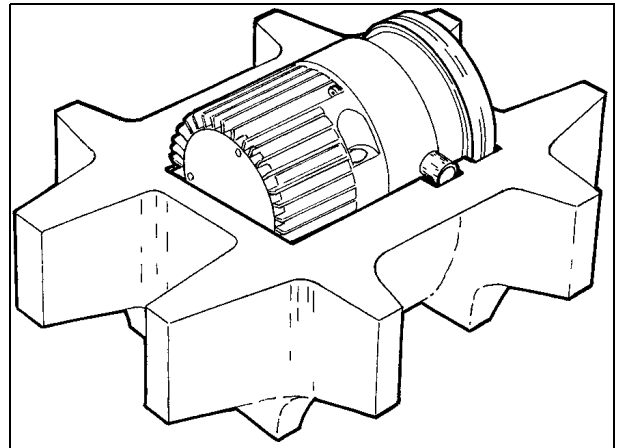

MERK

Normale miljømessige belastninger kan ikke ødelegge pumpen. Likevel anbefaler vi å holde den lukket til den er montert i systemet, slik at den ikke forurenses eller utsettes for nedstøving.

INSTALLASJON

Ikke installer eller bruk pumpen i miljøer som utsettes for regn, snø eller is, støv, aggressive gasser, eksplosjonsfarlige miljøer eller miljøer med stor brannfare.

Under bruk må følgende forhold respekteres:

- maksimalt trykk: 2 bar
- temperatur: fra $+5^{\circ}\text{C}$ til $+35^{\circ}\text{C}$
- relativ fuktighet: 0 - 95% (uten kondens)

Turbo-V 70D serien turbo-molekulære pumper må kun brukes med en av de spesielle Varian kontrollere (969-9405, 969-9505, 969-9507 eller 969-9508), og må koples til hovedpumpen (se skjema i "Teknisk informasjon").



FORSIKTIG

Ikke fjern klebemerket og det beskyttende dekslet før turbopumpen skal festes til systemet

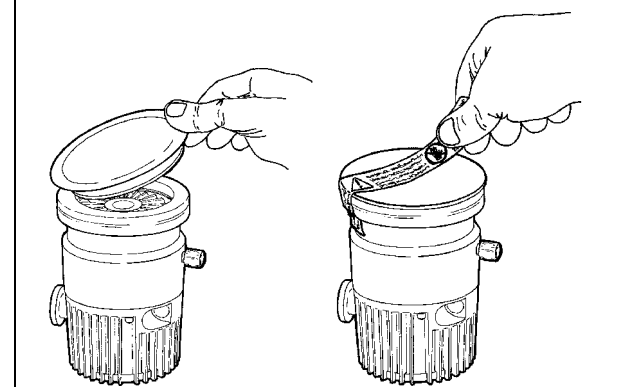



Turbopumpen kan monteres i en valgfri stilling. Fest turbopumpen i en stabil stilling med inngangsfleisen festet mot en koplingsflens med et dreiemoment på 200 Nm rundt akselen, eller ved å bruke bunnfestesettet.

Turbopumpene med ISO innløpsflens skal festes til vakuumkanteret med dobbel eller enkel klemmer. Følgende tabell angir det nødvendige antall klemmer og det relevante strammemomentet for de enkelte flensdimensjonene.

FLENS	TYPE KLEMME	ANTALL	STRAMME-MOMENT
ISO 63	Dobbel klemme gjenge M10	4	22 Nm
	Enkel klemme gjenge M8	4	11 Nm

Turbopumpen med innløpsflens ConFlat skal festes på vakuumkanteret ved hjelp av de spesielle låsedelene fra Varian. For detaljer henvises det til "Teknisk informasjon".

For å feste pumpen til fundamentet er det nødvendig å bruke tre M4-skruer, som skrues fast i hullene på pumpens fundament. Skruene skal klare en belastning på 500 N/mm² skruenes riktige strammemoment er 0,9 Nm.

For installasjon av tilleggsutstyr vises det til "Teknisk informasjon".

BRUK

Alle instruksjoner for korrekt bruk av turbopumpen finnes i kontrollenhetens manual.

Les nøye gjennom denne manualen før pumpen tas i bruk.

For å øke trykkgrensene kan pumpehuset varmes opp med en varmer som kan fås som ekstrautstyr. Mens oppvarmingen av kammeret pågår må temperaturen ved inngangsfleisen ikke overskride 120°C.

Bruk alltid vannavkjøling under oppvarmingen

ADVARSEL!

Ikke berør turbopumpen eller noe av tilleggsutstyret under oppvarmingen. De høye temperaturene kan føre til brannskader.

FORSIKTIG

Bruk støv- og partikkelfri luft eller inaktiv gass ved lufting av pumpen. Trykket ved inngangen må ikke være mindre enn 2 bar.

FORSIKTIG

Unngå støt, svingninger eller plutselige bevegelser av turbinpumpen når den er i funksjon. Lagrene kan skades.

FORSIKTIG

Ved pumping av aggressive gasser må det brukes spesialversjoner av Turbo - V 70D pumpen. Disse pumpene har en spesiell port som kan brukes til flyt av inaktive gasser med trykk mellom 0.4 og 1 mbar l/s.

VEDLIKEHOLD

Turbo-V 70D serien pumper er vedlikeholdsfrie. Alt arbeid på pumpen må kun utføres av autorisert personell.

ADVARSEL!

Før noe arbeid gjøres på turbopumpen må den frakoples tilførselen, den må luftes ved å åpne den aktuelle ventilen og deretter vente til rotoren har stanset og pumpens overflatetemperatur er lavere enn 50°C.

Dersom pumpen stanser, må du ta kontakt med Varians reparasjonsservice eller med Varians avanserte bytteservice som kan tilby overholte pumper til erstatning for den ødelagte pumpen.

MERK

Før pumpen returneres til produsenten for reparasjon, eller som innbytte for en overholt pumpe, må det vedlagte skjemaet "Helse og sikkerhet" fylles inn og sendes til det lokale salgskontoret. En kopi av dette arket må vedlegges pumpen som sendes tilbake.

Dersom en pumpe skal kasseres, må dette skje i henhold til nasjonale bestemmelser.

YLEISIÄ TIETOJA

Tämä laite on tarkoitettu ammattimaiseen käyttöön. Ennen laitteen käyttöönottoa tulee käyttäjän lukea huolellisesti mukana seuraava käyttöohje sekä kaikki muu Varianin toimittama lisätieto. Varian ei ota vastuuta seurauksista, jotka johtuvat laitteen käyttöohjeiden täydestä tai osittaisesta laiminlyönnistä, ammattitaidottoman henkilön virheellisestä laitteen käytöstä, valtuuttamattomista toimenpiteistä tai kansallisen lainsäädännön vastaisesta käytöstä. Turbo-V 70D sarjan pumput ovat korkean ja ultrakorkean tyhjiön käyttöön tarkoitettuja kaikyntyyppisiä kaasuja tai kaasukoostumien pumppaavia turbomolekyylipumppuja. Ne eivät sovellu nesteiden tai kiinteiden hiukkasten pumppaukseen. Pumpaus saadaan aikaan korkealla nopeudella (75000 kierrosta/min. max) pyörivän turbiinin avulla, jonka korkeatehoinen kolmivaiheinen sähkömoottori käynnistää. Turbo-V 70D sarjan pumpeissa ei ole lainkaan liikaavia aineita, joten ne soveltuvat myös "puhdasta" tyhjiötä vaativiin käyttötärpeisiin. Seuraavilla sivuilla on luettavissa kaikki tarpeellinen tieto laitteen käyttäjän turvallisuuden takaamiseksi laitteen käytön aikana. Yksityiskohtaista tietoa saa osasta "Technical Information".

Tämä käsikirja käyttää seuraavanlaisia merkintöjä:



VAARA!

Vaara-merkit saavat käyttäjän kiinnittämään huomion erityiseen käyttö- tai toimintatapaan, joiden vääränlainen suoritus voi johtaa vakaviin henkilövaurioihin.



HUOMIO

Huomio-merkit ovat nähtävissä ennen toimintatapoja, joiden laiminlyönti voi johtaa laitteen vahingoittumiseen.

HUOMAUTUKSET

Huomautuksissa käyvät ilmi tekstissä käsitellyt tärkeät tiedot.

VARASTOINTI

Noudata seuraavia ohjeita, jotta Varian turbomolekyylinen pumppu toimisi erittäin tehokkaasti ja luotettavasti:

- Kun pumppua kuljetetaan, siirretään ja varastoidaan, seuraavia ympäröiviä olosuhteita ei tule ylittää:
 - lämpötila: -20 °C - 70 °C.
 - suhteellinen kosteus: 0 - 95% (ei tiivistävä).
- Asiakkaan tulee aina käynnistää turbomolekyylinen pumppu soft-start-tavalla vastaanottaessaan pumpun ja käyttäessään sitä ensimmäisen kerran.
- Turbomolekyylisen pumpun varastointiaika on 10 kuukautta toimituspäivästä.



HUOMIO!

Jos varastointiaika on jostain syystä pidempi, pumppu tulee palauttaa tehtaalte. Pyydä lisätietoja paikalliselta Varian-edustajalta.

VALMISTELUT ASENNUSTA VARTEN

Pumpun toimitus tapahtuu erityisessä suojaavassa pakkauksessa; mikäli havaittavissa on mahdollisesti kuljetuksen aikana tapahtuneita vaurioita, ottakaa yhteys paikalliseen myyntitoimistoon.

Pakkauksen purkamisen aikana tulee varoa erityisesti pumpun putoamista tai siihen kohdistuvia iskuja.

Pakkausta ei tule jättää ympäristöön. Pakkausmateriaali on täysin kierrätettävä ja se vastaa EEC 85/399 direktiiviä ympäristön suojelusta.



HUOMIO

Jotta kaasun poistumisongelmilta vältyttäisiin, ei tyhjiön tarkoitettuihin osiin tule koskea paljain käsin. Hanskojen tai muun sopivan suojan käyttö on tarpeellinen.

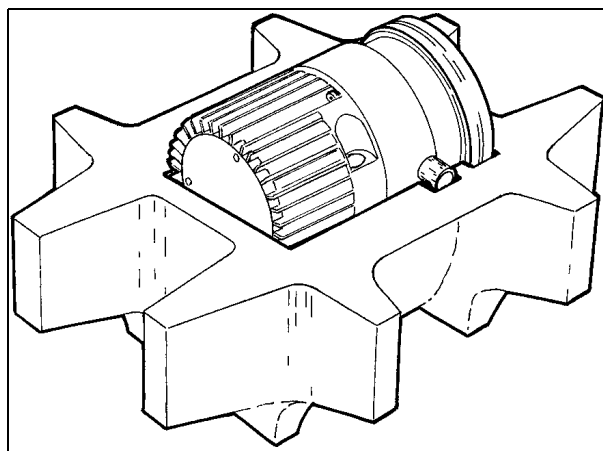

HUOMAUTUKSET

Pumppu ei vahingoitu sen ollessa yksinkertaisesti avoinna. On kuitenkin suositeltavaa pitää se suljettuna kunnes se kytketään järjestelmään, jotta vältettäisiin sen mahdollinen saastuminen pölyltä.

ASENNUS

Pumppua ei tule asentaa eikä käyttää ympäristössä, missä se joutuu kosketuksiin sateen, jään tai lumen, pölyn tai aggressiivisten kaasujen kanssa tai joissa on olemassa räjähdys- tai tulipalovaara. Käytön aikana on tarpeellista noudattaa seuraavia ympäristöä koskevia ehtoja:

- maksimipaine: 2 bar
- lämpötila: + 5°C - +35°C
- suhteellinen kosteus: 0 - 95 % (ei tiivistävä).

Sarjan V 70D turbomolekyylipumppuja tulee käyttää ainoastaan niihin sopivien varian valvojen kanssa (sarja 969-9405, 969-9505, 969-9507 tai 969-9508) ja niiden täytyy olla yhdistettyinä pääpumppuun (katso kaaviota osasta "Technical Information").



HUOMIO

Irrottakaa tarra ja poistakaa suojakansi sillä hetkellä kun turbopumppu liitetään järjestelmään.

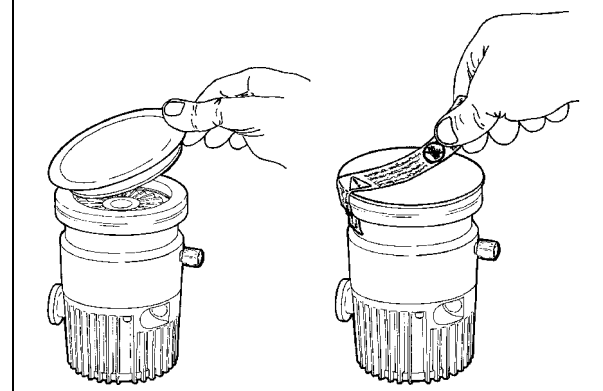

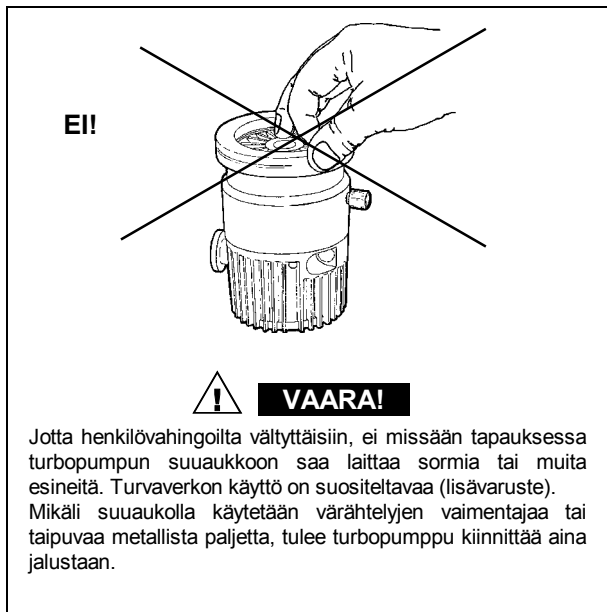

Turbopumppu voidaan asentaa mihin tahansa asentoon. Turbopumppu tulee kiinnittää vakaaseen asentoon liittämällä turbopumpun sisääntulolaippa kiinteään vastalaippaan, joka kannattaa 200 Nm paria akselinsa ympärillä, tai käyttäen tarkoitukseen sopivia lisävarusteita sen kiinnittämiseen. Turbopumppu ISO sisääntulolaipalla tulee kiinnittää tyhjiökammariin kaksois kiinnikkeillä tai yksinkertaisilla kiinnikkeillä. Seuraava taulukko kuvaa kaikki laippakoot ja kiinnikemallit, kiinnikkeiden tarpeellisen määrän ja kiristysmomentti.

LAIPPA	KIINNIKE	MÄÄRÄ	KIRISTYSMO- ENTTI
ISO 63	Kaksoiskiinnike, kierteyks M10	4	22 Nm
	Yksinkertainen kiinnike, kierteyks M8	4	11 Nm

Torbopumppu ConFlat sisääntulolaipalla tulee kiinnittää tyhjiökammariin sopivien Varian mekaanisten varusteiden avulla. Lisätietoja löytyy ©Technical Information©-liitteestä. Pumppu tulee kiinnittää jalustan avulla käyttäen kolmea M4 ruuvia jotka on kiinnitetty sopiviin pumpun jalustassa oleviin rakoisiin. Ruuveilla tulee olla venytysrasitus joka vastaa 500 N/mm², ja tulee kiinnittää 0,9 Nm momentilla. Lisälaitteiden asennuksen ohjeet ovat nähtävissä "Technical Information" osassa.

KÄYTTÖ

Turbopumpun oikeaoppiseen käyttöön tarvittavat ohjeet löytyvät valvojan käsikirjasta.

Lukekaa huolellisesti kyseinen käsikirja ennen käyttöönottoa. Jotta saavutettaisiin paremmat rajapaineet, on pumpun kotelon kuumentaminen mahdollista käyttämällä lisätilauksesta saatavaa kuumenninta. Tyhjiökammion mahdollisen kuumentamisen aikana ei sisääntohtavan laipan lämpötila saa olla yli 120 °C. Käyttäkää aina kuumentamisen aikana vettä jäähdytykseen.



VAARA!

Älkää koskeko turbopumppuun tai sen lisäosiin kuumentamisen aikana. Korkea lämpötila voi saada aikaan henkilöiden loukkaantumisia.



HUOMIO

Päästettäessä pumppuun ilmaa tulee käyttää ilmaa tai jalokaasua, joissa ei ole pölyä tai hiukkasia. Sisäänjohtavan paineen siihen sopivan aukon läpi täytyy olla alle 2 bar:ia.



HUOMIO

Vältä kolhuja, heiluntaa tai äkkiliikkeitä turbopumpun toiminnan aikana, sillä laakerit voivat vahingoittua.



HUOMIO

Aggressiivisten kaasujen pumppauksessa käyttäkää ainoastaan Turbo-V70D pumpun erikoisversiota. Näissä pumpeissa on aukko, jonka läpi on kuljettava 0.4 ja 1 mbar l/s:n välillä oleva jalokaasuvirta.

HUOLTO

Sarjan Turbo-V 70D pumput eivät vaadi lainkaan huoltoa. Minkä tahansa toimenpiteen täytyy suorittaa siihen valtuutettu henkilö.



VAARA!

Ennen minkään tyyppistä toimenpidettä ottakaa pois päältä verkkovirta, päästäkää pumppuun ilmaa avaten siihen tarkoitettu venttiili ja odottakaa roottorin täydellistä pysähtymistä ja että pumpun pintalämpö on alle 50°.

Laitteen vahingoituessa on mahdollista käyttää Varianin korjauspalvelua tai "Varian advanced exchange service", joka mahdollistaa regeneroidun pumpun saamisen vahingoittuneen tilalle.

HUOMAUTUS

Ennen pumpun lähettämistä valmistajalle korjausta tai advanced exchange serviceä varten, on ehdottomasti täytettävä ja toimitettava paikalliseen myyntitoimistoon "Turvallisuus ja Terveys"-kaavake, joka löytyy liitteenä ohjekirjan mukana. Kyseisen kaavakkeen kopio tulee liittää pumpun pakkaukseen ennen sen lähettämistä.

Mikäli pumppu täytyy romuttaa, toimikaa kansallisen lainsäädännön määräämällä tavalla.

ΓΕΝΙΚΕΣ ΠΛΗΡΟΦΟΡΙΕΣ

Αυτή η συσκευή προορίζεται για επαγγελματική χρήση. Ο χρήστης θα πρέπει να διαβάσει προσεκτικά τις οδηγίες του παραντος εγχειριδίου και οποιαδήποτε άλλη πρό σθετη πληροφορία που δίνει η Varian, πριν από τη χρησιμοποίηση της συσκευής.

Η Varian δεν φέρει καμία ευθύ νη ό σον αφορά την ολική ή μερική αθέτηση των οδηγιών, την ακατάλληλη χρήση εκ μέρους ανεκπαίδευτου προσωπικού, αυθαίρετες επεμβάσεις ή χρήση που δεν συμφωνεί με τις ειδικές εθνικές διατάξεις.

Οι αντλίες της κατηγορίας Turbo-V 70D είναι (στροβιλομοριακές) αντλίες (ή μοριακές τουρμπίνες) για εφαρμογές υψηλού και πολύ υψηλού κενού, ικανές να αντλήσουν κάθε είδους αέριο. Είναι ακατάλληλες για την άντληση υγρών ή στερεών σωματιδίων.

Η άντληση επιτυγχάνεται διαμέσου μίας τουρμπίνας που περιστρέφεται με μεγάλη ταχύτητα (το ανώτερο 75000 σ.α.λ.), η οποία κινείται από ένα τριφασικό ηλεκτρικό μοτέρ υψηλής από δοσης. Οι αντλίες Turbo-V 70D δεν περιέχουν ρυπαντικούς παράγοντες, είναι κατάλληλες λοιπόν και για εφαρμογές που απαιτού ν ένα "καθαρό " κενό .

Στις επό μενες παραγράφους αναφέρονται ό λες οι απαραίτητες πληροφορίες που εγγυού νται την ασφάλεια του χειριστή κατά τη διάρκεια της χρησιμοποίησης της συσκευής. Λεπτομερείς πληροφορίες δίνονται στο παράρτημα " Τεχνικές Πληροφορίες ".

Αυτο το εγχειρίδιο χρησιμοποιεί τις ακό λουθες συμβάσεις:

**ΚΙΝΔΥΝΟΣ!**

Οι ενδείξεις κινδύ νου ελκύ ουν την προσοχή του χειριστή σε μια διαδικασία ή σε μια ειδική εργασία η οποία εάν δεν εκτελεστεί σωστά, θα μπορού σε να προκαλέσει σοβαρές προσωπικές βλάβες.

**ΠΡΟΣΟΧΗ!**

Οι ενδείξεις προσοχής εμφανίζονται πριν από τις διαδικασίες οι οποίες εάν δεν εκτελεστού ν με προσοχή, θα μπορού σαν να προκαλέσουν ζημιές στη συσκευή.

ΣΗΜΕΙΩΣΗ

Οι σημειώσεις περιέχουν σημαντικές πληροφορίες που έχουν αποσπαστεί από το κείμενο.

ΑΠΟΘΗΚΕΥΣΗ

Για να εγγυηθεί το Μέγιστο επίπεδο λειτουργικό τητας και αξιοπιστίας των Στροβιλομοριακών αντλιών ηφιαριαν, πρέπει να τηρού νται οι εξής προδιαγραφέςή

- κατά τη μεταφορά, τη διακίνηση και την αποθήκευση των αντλιών δεν πρέπει να υπερβαίνονται οι εξής περιβαλλοντικές συνθήκεςή
 - θερμοκρασίαή από - 20 ºΧ έως 70 ºΧ
 - σχετική υγρασίαή από 0 έως 95% (μη συμπυκνώσιμη)
- ο πελάτης πρέπει να ανόβει τις στροβιλομοριακές αντλίες με τον τρό πο Σοφτ-Σταρτ ό ταν παραλαμβάνονται και θέτονται σε λειτουργία για πρώτη φορά
- ο χρό νος αποθήκευσης μίας στροβιλομοριακής αντλίας είναι 10 μήνες από την ημερομηνία αποστολής.

**ΠΡΟΣΟΧΗ!**

Εάν, για οποιοδήποτε λόγο, ο χρό νος αποθήκευσης είναι μεγαλύτερος, χρειάζεται να επιστρέψετε την αντλία στο εργοστάσιο. Για κάθε πληροφορία, παρακαλού με να επικοινωνήσετε με την τοπική αντιπροσωπεία της ηφιαριαν.

ΠΡΟΕΤΟΙΜΑΣΙΑ ΓΙΑ ΤΗΝ ΕΓΚΑΤΑΣΤΑΣΗ

Η αντλία εναι εξοπλισμένη με μία ευρύχωρη προστατευτική συσκευασία. Αν υπάρχουν ενδείξεις βλάβης που θα μπορού σαν να έχουν προκληθεί κατά τη διάρκεια της μεταφοράς, συμβουλευτείτε το τοπικό τμήμα πωλήσεων.

Κατά τη διάρκεια του ανοίγματος της συσκευασίας, δάψτε ιδιαίτερη προσοχή έτσι ώστε να μην πέσει και να μην χτυπηθεί η αντλία.

Μην εγκαταλείπετε τη συσκευασία στο περιβάλλον. Το υλικό ανακυκλώνεται πλήρως και ανταποκρίνεται στην Οδηγία της Ε.Ε. 85/399 για τη διαφύ λαξη του περιβάλλοντος.

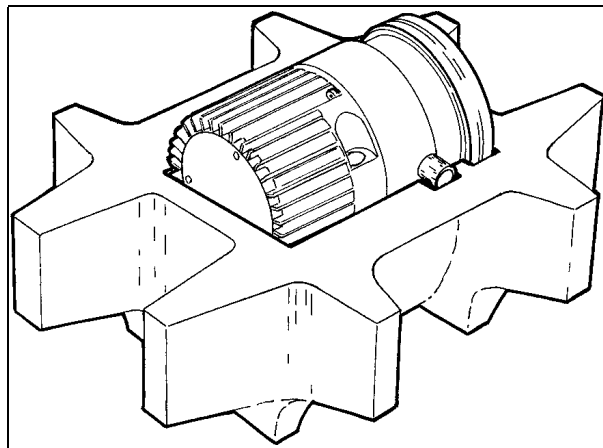
**ΠΡΟΣΟΧΗ!**

Προκειμένου να αποφύ γετε προβλήματα από την αελευθέρωση αερίου, μην αγγίζετε με γυμνά χέρια τα τμήματα που πρό κειται να εκτεθού ν στο κενό . Να χρησιμοποιείτε πάντα γάντια ή άλλη κατάλληλη προστασία.

ΣΗΜΕΙΩΣΗ

Η αντλία δεν καταστρέφεται εάν απλά εκτεθεί στον ατμοσφαιρικό αέρα. Σας συμβουλεύ ουμε ό μως να την κρατήσετε κλειστή μέχρι τη στιγμή που θα εγκατασταθεί στο σύστημα, έτσι ώστε να αποφευχθεί η ενδεχό μενη ρύπανση από τη σκό νη.

ΕΓΚΑΤΑΣΤΑΣΗ

Η αντλία δεν θα πρέπει να εγκατασταθεί και-ή να χρησιμοποιηθεί σε χώρους εκτεθειμένους σε ατμοσφαιρικούς παράγοντες (βροχή, πάγο, χιό νι), σκό νες, χημικά αέρια, σε χώρους ό που υπάρχει κίνδυνος έκρηξης ή κίνδυνος πυρκαγιάς.

Κατά τη διάρκεια της λειτουργίας πρέπει να τηρού νται οι ακό λουθες συνθήκες περιβάλλοντος:

- max. πίεση: 2 bar
- θερμοκρασία: από +5°C μέχρι +35°C
- σχετική υγρασία: 0 - 95 % (αυτοαποξηραντική).

**ΠΡΟΣΟΧΗ!**

Ξεκολλάτε το αυτοκό λλητο και βγάξτε το προστατευτικό καπάκι μό νον τη στιγμή της σύ νδεσης της τουρμποαντλίας στο σύστημα.

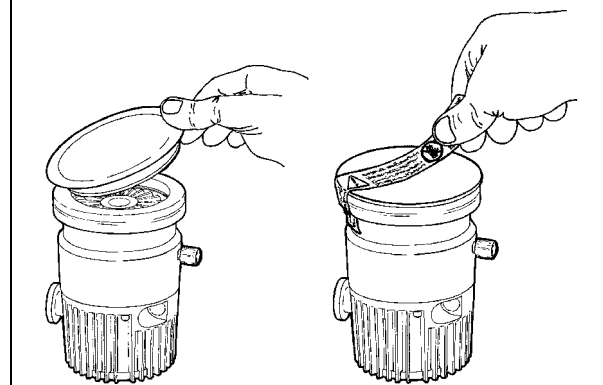

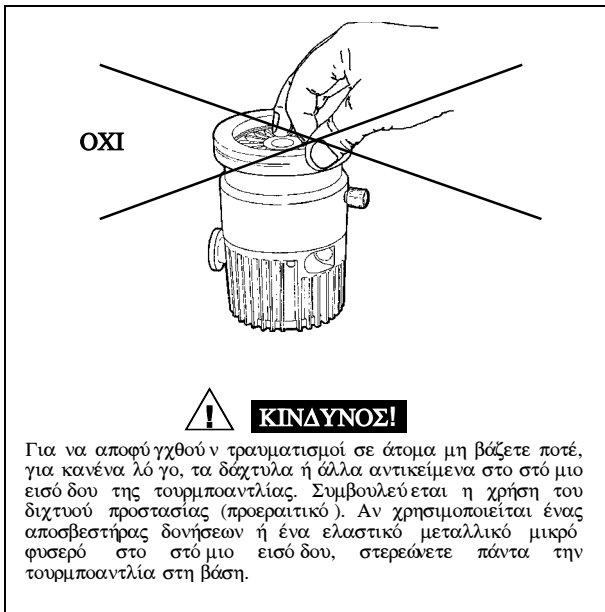

Για να αποφευχθούν τραυματισμοί σε άτομα μη βάζετε ποτέ, για κανένα λόγο, τα δάχτυλα ή άλλα αντικείμενα στο στόμιο εισόδου της τουρμποαντλίας. Συμβουλεύεται η χρήση του διχτυού προστασίας (προαιρετικό). Αν χρησιμοποιείται ένας αποσβεστήρας δονήσεων ή ένα ελαστικό μεταλλικό μικρό φυσερό στο στόμιο εισόδου, στερεώνετε πάντα την τουρμποαντλία στη βάση.

Οι τουρμπομοριακές αντλίες της σειράς Turbo-V70D πρέπει να χρησιμοποιούνται μόνο με έναν από τους ειδικούς ελέγχους Varian (σειρά 969-9405, 969-9505, 969-9507 ή 969-9508) και πρέπει να είναι συνδεδεμένες με μία πρωτεύουσα αντλία (βλέπε σχήμα στις "Τεχνικές Πληροφορίες").

Η τουρμποαντλία μπορεί να τοποθετηθεί σε οποιαδήποτε θέση. Στερεώστε την τουρμποαντλία σε σταθερή θέση ενώνοντας τη φλάντζα εισόδου με μία σταθερή κόντροφλάντζα ικανή να συγκρατήσει ένα ζευγάρι 200 Nm γύρω από τον άξονά της, ή χρησιμοποιήστε το κατάλληλο σχετικό κιτ για να σταθεροποιήσετε τη βάση.

Η τουρμποαντλία με φλάντζα εισόδου ISO πρέπει να στερεωθεί στο θάλαμο κενού μέσω διπλών ή μονών μέγγενων. Η ακόλουθη ταμπέλα περιγράφει το απαραίτητο νούμερο μέγγενων και με ποιο ζεύγος βιδώματος να τα σφίξετε.

ΦΛΑΝΤΖΑ	ΤΥΠΟΣ ΜΕΓΓΕΝΗΣ	N.	ΖΕΥΓΟΣ ΒΙΔΩΜΑΤΟΣ
ISO 63	Διπλή μέγγενη με ελίκωση M10	4	22 Nm
	Μονή μέγγενη με ελίκωση M8	4	11 Nm

Η τουρμποαντλία με φλάντζα εισόδου ConFlat πρέπει να στερεωθεί στο θάλαμο κενού μέσω των κατάλληλων μηχανικών εξαρτημάτων Varian. Για περισσότερες λεπτομέρειες βλέπε την επιφυλλίδα "Τεχνικές Πληροφορίες".

Για να στερεώσετε την αντλία μέσω της βάσης της είναι απαραίτητο να χρησιμοποιήσετε τρεις βίδες M4 στερεώστε στην ειδική οπή που υπάρχουν στη βάση της αντλίας. Οι χρησιμοποιούμενες βίδες πρέπει να έχουν αντοχή 500 N/mm², και πρέπει να στερεωθούν με ένα ζευγάρι 0,9 Nm.

Για την εγκατάσταση των προαιρετικών αξεσουάρ, βλέπε "Τεχνικές Πληροφορίες".

ΧΡΗΣΗ

Όλες οι οδηγίες για τη σωστή λειτουργία της τουρμποαντλίας περιέχονται στο εγχειρίδιο ελέγχου.

Διαβάστε προσεκτικά αυτό το εγχειρίδιο πριν από τη χρήση. Για να επιτύχετε καλύτερες οριακές πιέσεις μπορείτε να θερμάνετε το περίβλημα της αντλίας χρησιμοποιώντας τον έξτρα θερμαντή. Κατά τη διάρκεια της ενδεχόμενης θέρμανσης του θαλάμου κενού η θερμοκρασία στη φλάντζα εισόδου δεν πρέπει να ξεπερνάει τους 120°C. Κατά τη θέρμανση να χρησιμοποιείτε πάντα γρήγη ψύξη.

⚠ KINΔYΝΟΣ!

Μην αγγίζετε την τουρμποαντλία και τα διάφορα εξαρτήματά της κατά τις εργασίες θέρμανσης. Η υψηλή θερμοκρασία μπορεί να προκαλέσει προσωπικές βλάβες.

👉 ΠΡΟΣΟΧΗ!

Για να διοχετεύσετε με αέρα την αντλία χρησιμοποιήστε αέρα ή αδρανές αέριο καθαρό από σκόνη ή άλλα στοιχεία. Η πίεση εισόδου διαμέσου της ειδικής πόρτας, πρέπει να είναι μικρότερη από 2 bar.

👉 ΠΡΟΣΟΧΗ!

Αποφύγετε συγκρούσεις, ολισθησεις ή αποτομική μετακινήσεις της αντλίας ή του αεροπλάσματος όταν βρίσκεται σε λειτουργία. Θα μπορούσαν να παραθούν ζημιές ή τα κομμάτια.

👉 ΠΡΟΣΟΧΗ!

Για την άντληση πολεμικών αερίων χρησιμοποιήστε μόνο τις εκδόσεις της αντλίας Turbo - V70D. Αυτές οι αντλίες είναι εφοδιασμένες με μια ειδική θυρά μω της οποίας είναι αναγκαία η διοχύτευση αδρανούς αερίου που να κυμαίνεται μεταξύ 0.4 και 1μβαρλ.δ.

ΣΥΝΤΗΡΗΣΗ

Οι αντλίες της κατηγορίας Turbo - V70D δε χρειάζονται καμμία συντήρηση. Οποιαδήποτε επέμβαση πρέπει να γίνεται από ειδικευμένο προσωπικό.

⚠ KINΔYΝΟΣ!

Πριν επιχειρήσετε οποιαδήποτε επέμβαση στην τουρμποαντλία, αποσυνδέστε το καλώδιο τροφοδοσίας, κάντε εξάερωση στην αντλία ανοίγοντας την ειδική βαλβίδα και περιμένετε μέχρι να σταματήσει τελείως το μοτέρ.

Σε περίπτωση βλάβης μπορείτε να απευθυνθείτε στο service της Varian ή στο "Varian advanced exchange service", που σας δίνει τη δυνατότητα να αντικαταστήσετε την χαλασμένη αντλία με μία άλλη ενισχυμένη.

ΣΗΜΕΙΩΣΗ

Πριν επιστρέψετε στον κατασκευαστή την αντλία για επισκευή ή για advanced exchange service, είναι απαραίτητο να συμπληρώσετε και να παρουσιάσετε στο τοπικό Γραφείο Πωλήσεων, το έντυπο - Σιγουριά και υγεία- συνημμένο στο παρόν εγχειρίδιο οδηγιών. Αντίγραφο του ίδιου εντύπου πρέπει να υπάρχει μέσα στη συσκευασία της αντλίας πριν από την αποστολή.

Όταν πλέον παύσει να λειτουργεί η αντλία θα πρέπει να καταστραφεί σύμφωνα με τους ειδικούς εθνικούς κανονισμούς.

GENERAL INFORMATION

This equipment is destined for use by professionals. The user should read this instruction manual and any other additional information supplied by Varian before operating the equipment. Varian will not be held responsible for any events occurring due to non-compliance, even partial, with these instructions, improper use by untrained persons, non-authorized interference with the equipment or any action contrary to that provided for by specific national standards.

The Turbo-V 70D series pumps are turbo-molecular pumps for high and ultra-high vacuum applications and can pump any type of gas or gas compound. They are not suitable for pumping liquids or solid particles. The pumping action is obtained through a high speed turbine (max. 75000 rpm) driven by a high-performance 3-phase electric motor. The Turbo-V 70D pumps are free of contaminating agents and, therefore, are suitable for applications requiring a "clean" vacuum.

The following paragraphs contain all the information necessary to guarantee the safety of the operator when using the equipment. Detailed information is supplied in the appendix "Technical Information".

This manual uses the following standard protocol:



WARNING!

The warning messages are for attracting the attention of the operator to a particular procedure or practice which, if not followed correctly, could lead to serious injury.



CAUTION

The caution messages are displayed before procedures which, if not followed, could cause damage to the equipment.

NOTE

The notes contain important information taken from the text.

STORAGE

In order to guarantee the maximum level of performance and reliability of Varian Turbomolecular pumps, the following guidelines must be followed:

- when shipping, moving and storing pumps, the following environmental specifications should not be exceeded:
 - temperature range: -20 °C to 70 °C
 - relative humidity range: 0 to 95% (non condensing)
- the turbomolecular pumps must be always soft-started when received and operated for the first time by the customer
- the shelf life of a turbomolecular pump is 10 months from the shipping date.



CAUTION

If for any reason the shelf life time is exceeded, the pump has to be returned to the factory. Please contact the local Varian Vacuum Sales and Service representative for informations.

PREPARATION FOR INSTALLATION

The pump is supplied in a special protective packing. If this shows signs of damage which may have occurred during transport, contact your local sales office.

When unpacking the pump, be sure not to drop it and avoid any kind of sudden impact or shock vibration to it.

Do not dispose of the packing materials in an unauthorized manner. The material is 100% recyclable and complies with EEC Directive 85/399.

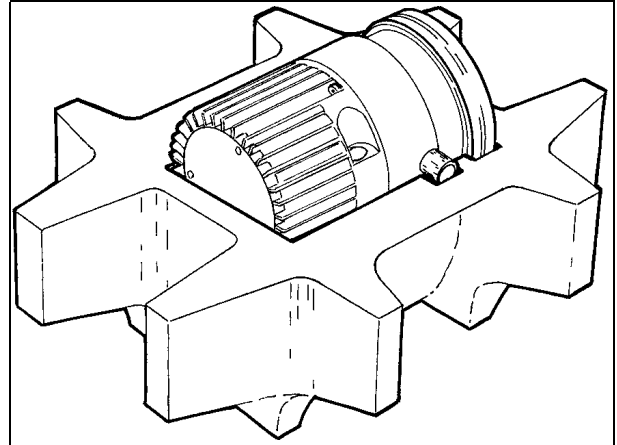

CAUTION

In order to prevent outgassing problems, do not use bare hands to handle components which will be exposed to vacuum. Always use gloves or other appropriate protection.

NOTE

Normal exposure to the environment cannot damage the pump. Nevertheless, it is advisable to keep it closed until it is installed in the system, thus preventing any form of pollution by dust.

INSTALLATION

Do not install or use the pump in an environment exposed to atmospheric agents (rain, snow, ice), dust, aggressive gases, or in explosive environments or those with a high fire risk. During operation, the following environmental conditions must be respected:

- maximum pressure: 2 bar
- temperature: from +5 °C to +35 °C
- relative humidity: 0 - 95% (non-condensing)

The Turbo-V 70D series pumps must only be used with one of the special Varian controllers (series 969-9405, 969-9505, 969-9507 or 969-9508) and must be connected to a primary pump (see "Technical Information").

The turbopump can be installed in any position.

Fix the turbopump in a stable position connecting the inlet flange of the turbopump to a fixed counter-flange capable of withstanding a torque of 200 Nm around its axis, or use the optional base fixing kit



CAUTION!

Do not remove the adhesive and protective cap before connecting the turbopump to the system.

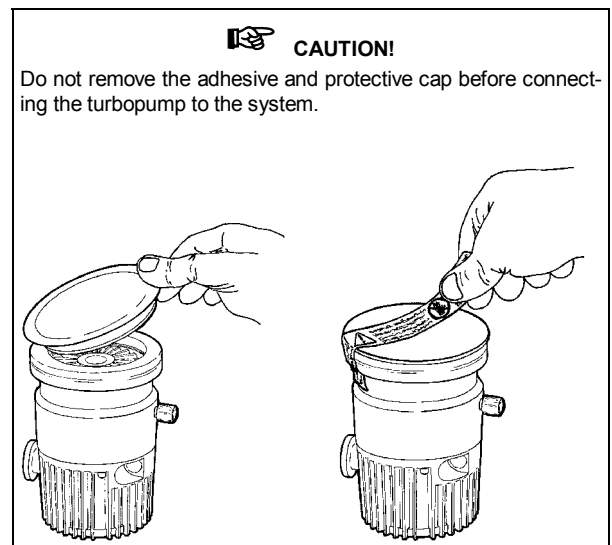

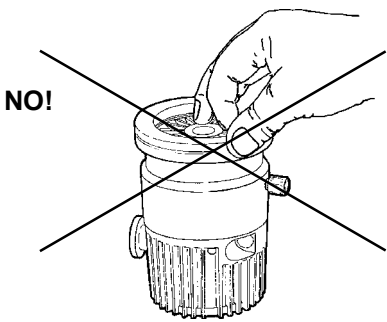

NO!

WARNING!

To avoid injury, never put fingers or any objects whatsoever in the inlet port of the turbopump. The use of the protective screen is strongly advised (optional extra). If a vibration damper or flexible metallic bellows are used on the inlet port, make sure that the pump is fixed to the base.

The turbopump with ISO inlet flange must be fixed to the vacuum chamber by means of clamps or claws. The following table shows, for each flange and fixing device, the necessary number of clamps or claws and the relevant fixing torque.

FLANGE	FIXING DEVICE	N.	FIXING TORQUE
ISO 63	M10 clamps	4	22 Nm
	M8 claws	4	11 Nm

The turbopump with ConFlat inlet flange must be fixed to the vacuum chamber by means of the appropriate Varian hardware. See the appendix "Technical Information" for a detailed description. To fix the pump by means of its base, it is necessary to use three M4 screws fixed to the foreseen holes of the pump base. The used screws must have a minimum strength point of 500 N/mm² and must be fixed with a torque of 0,9 Nm. For installation of optional accessories, see "Technical Information".

USE

All the instructions for the correct use of the turbopump are contained in the control unit manual. Read the manual carefully before using the pump. In order to achieve a better (lower) base pressure, the pump casing may be heated using the optional heater. While heating the pump, the temperature of its inlet flange must not exceed 120 °C. Always use the water cooling system during the heating operations.

WARNING!

Do not touch the turbopump or any of its accessories during the heating process. The high temperatures may cause burns.

CAUTION

Use air or inert gas free from dust or particles for venting the pump. The pressure at the vent port must be less than 2 bar.

CAUTION

Avoid impacts, oscillations or harsh movements of the pump when in operation. The bearings may become damaged.

CAUTION

For pumping aggressive gases, use the specially designed versions of the Turbo - V 70D pump. These pumps are fitted with a special port through which a flow of inert gas must be passed between 0,4 and 1 mbar l/s.

MAINTENANCE

The Turbo-V70D series pump does not require any maintenance. Any work performed on the pump must be carried out by authorized personnel.

WARNING!

Before carrying out any work on the turbopump, disconnect it from the supply, vent the pump by opening the appropriate valve, wait until the rotor has stopped turning and wait until the surface temperature of the pump falls below 50 °C.

In the case of breakdown, contact your local Varian service center who can supply a reconditioned pump to replace that broken down.

NOTE

Before returning the pump to the constructor for repairs, or replacement with a reconditioned unit, the "Health and Safety" sheet attached to this instruction manual must be filled-in and sent to the local sales office. A copy of the sheet must be inserted in the pump package before shipping.

If a pump is to be scrapped, it must be disposed of in accordance with the specific national standards.

DESCRIPTION OF THE TURBOPUMP

The Turbo-V70D pump is available in four versions. The difference between the two versions lies purely in the high vacuum connection. The four versions are:

- Model 969-9361 with ISO 63 high vacuum flange
- Model 969-9362 with ConFlat 4.5" external diameter high vacuum flange
- Model 969-9363 with KF 40 NW high vacuum flange
- Model 969-9364 with ConFlat 2.75" external diameter high vacuum flange

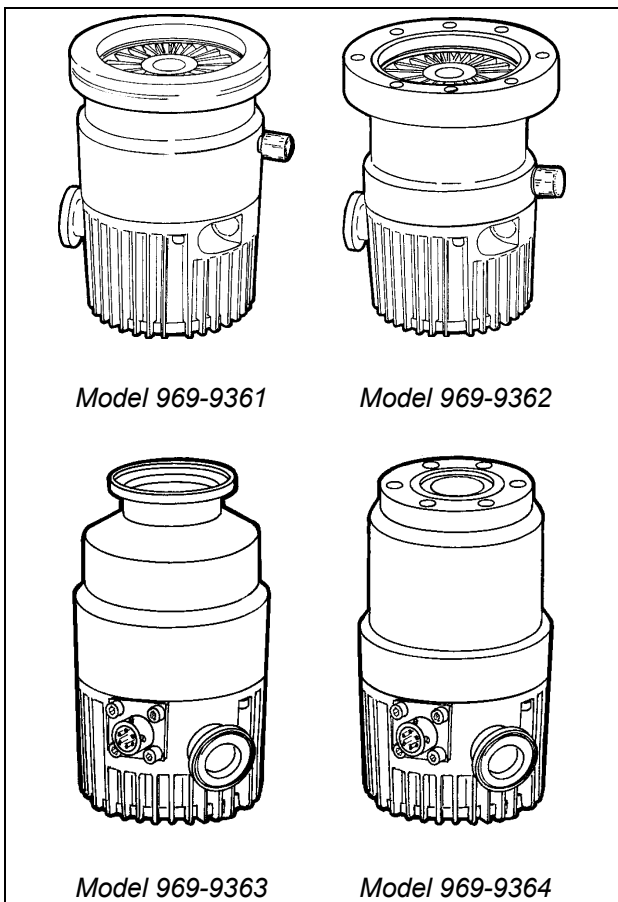

The Turbo-V70D pump consists of a high frequency motor driving a turbine fitted with 7 bladed stages and 4 Macrotrorr stages. The turbine rotates in an anticlockwise direction when viewed from the high vacuum flange end.

The turbine is made of high-strength, light aluminium alloy, and is machined from a single block of aluminium. The turbine blades have five different angles, from 42° to 12°, while the Macrotrorr stages are in the form of discs

The turbine rotor is supported by permanently lubricated high precision ceramic ball bearings installed on the forevacuum side of the pump.

The static blades of the stator are fabricated in stainless steel. These are supported and accurately positioned by spacer rings.

The Macrotrorr stators are in the form of self-positioning machined discs with pumping channels and an opening restricted by the corresponding rotor discs. These are fabricated in aluminium alloy

During normal operation, the motor functions with a power feed at 54 Vac three-phase at 1250 Hz. To reduce losses during start-up to a minimum, the frequency increases according to a ramp with a higher initial voltage/frequency ratio.

The external body of the pump is fitted with fins which allow the pump itself to function with natural convection air cooling. Kits are available for water cooling or forced air cooling to cool the pump in the cases where it is used under heavy load or when natural convection is insufficient for cooling purposes.

A thermistor sensor is mounted near the upper bearing to prevent the pump from overheating.

The thermistor sensor, the motor stator windings and the earth are connected to a Turbo-V controller through a 6 pin socket on the side of the pump.

The pump is balanced after assembly with a residual vibration amplitude less than 0.01 µm.

The pump can operate in any position and can be supported on the high vacuum flange or on its base. The connection of the forevacuum on the side of the pump is a KF 16 NW flange.

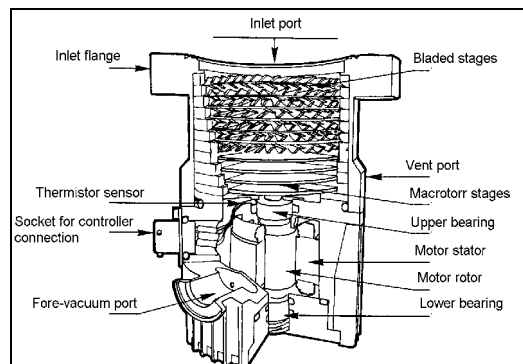

TECHNICAL SPECIFICATION

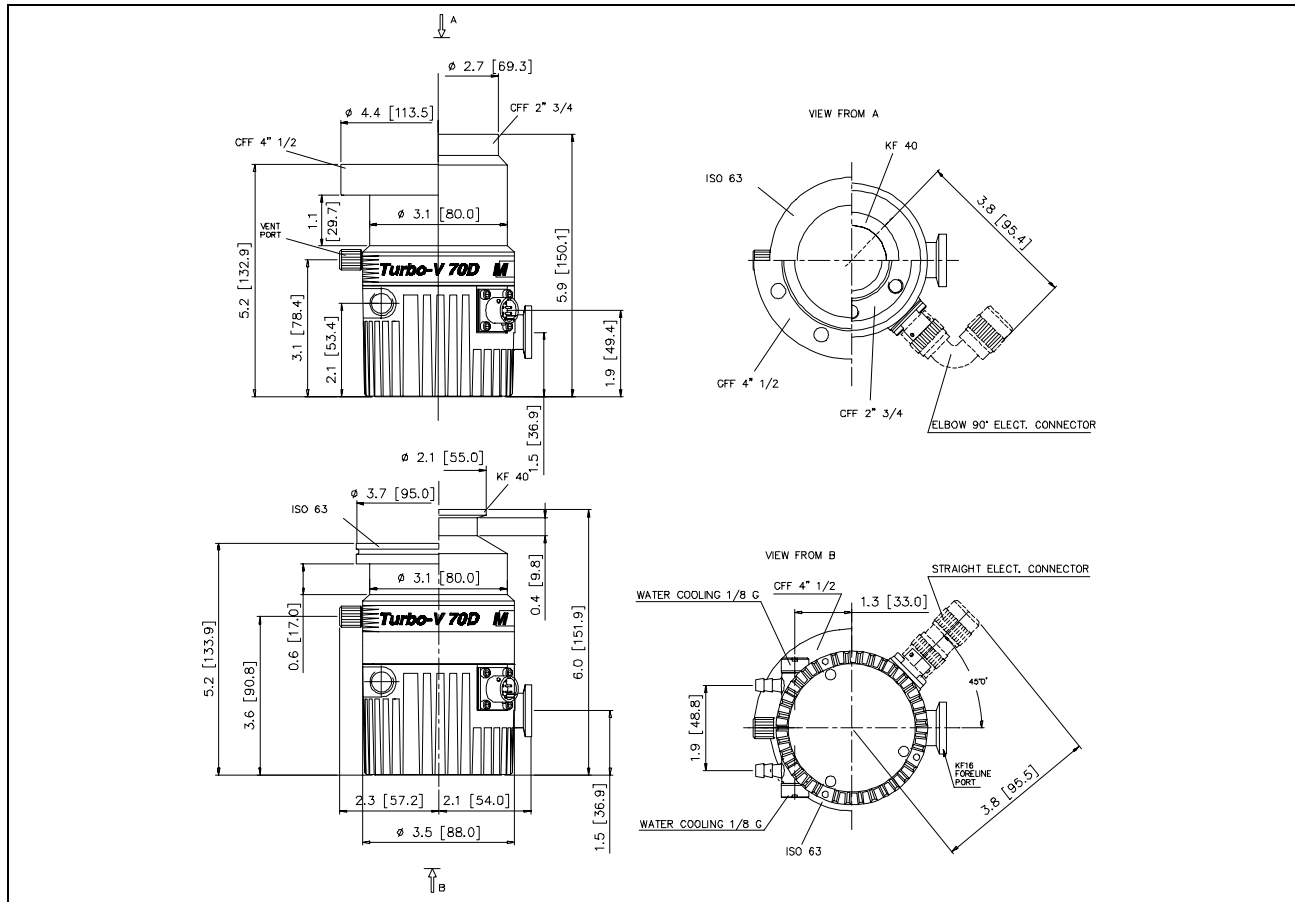

Pumping speed (l/s)	With CF 4.5" or ISO 63: N ₂ : 60 l/s He: 30 l/s H ₂ : 20 l/s	With CF 2.75" or KF 40 NW: N ₂ : 40 l/s He: 27 l/s H ₂ : 20 l/s
Compression ratio	N ₂ : 5 x 10 ⁷ He: 7 x 10 ³ H ₂ : 1.5 x 10 ³	
Base pressure*	with recommended mechanical fore pump: 1 x 10 ⁻⁹ mbar (8 x 10 ⁻¹⁰ Torr) with recommended diaphragm fore pump: 1 x 10 ⁻⁹ mbar (8 x 10 ⁻⁷ Torr)	
Inlet flange	CF 4.5" O.D. ISO63 CF 2.75" O.D. KF 40 NW	
Foreline flange	KF 16 NW	
Rotational speed	75000 RPM	
Start-up time	< 60 seconds	
Recommended fore-pump	mechanical: Varian SD-40 diaphragm: Varian MD 6	
Operating position	any	
Cooling requirements	Natural air convection Forced air or water optional	

Operating ambient temperature	+ 5° C to + 35° C
Coolant water	flow: 10 l/h (0.05 GPM) temperature: + 10° C to + 30° C pressure: 2 to 4 bar (30 to 60 Psi)
Bakeout temperature	120° C at inlet flange max. (CF flange) 80° C at inlet flange max. (ISO flange)
Vibration level (displacement)	< 0.01 μm at inlet flange
Noise level	45 dB (A) at 1 meter
Input	54 Vac, three phase, 1250 Hz
Lubricant	permanent lubrication
Installation category	II
Pollution degree	2
Storage temperature	- 20° C to + 70° C
Weight kg (lbs)	ISO: 2.3 (6) CFF: 1.6 (4)

* According to standard DIN 28 428, the base pressure is that measured in a leak-free test dome, 48 hours after the completion of test dome bake-out, with a Turbopump fitted with a ConFlat flange and using the recommended pre-vacuum pump.

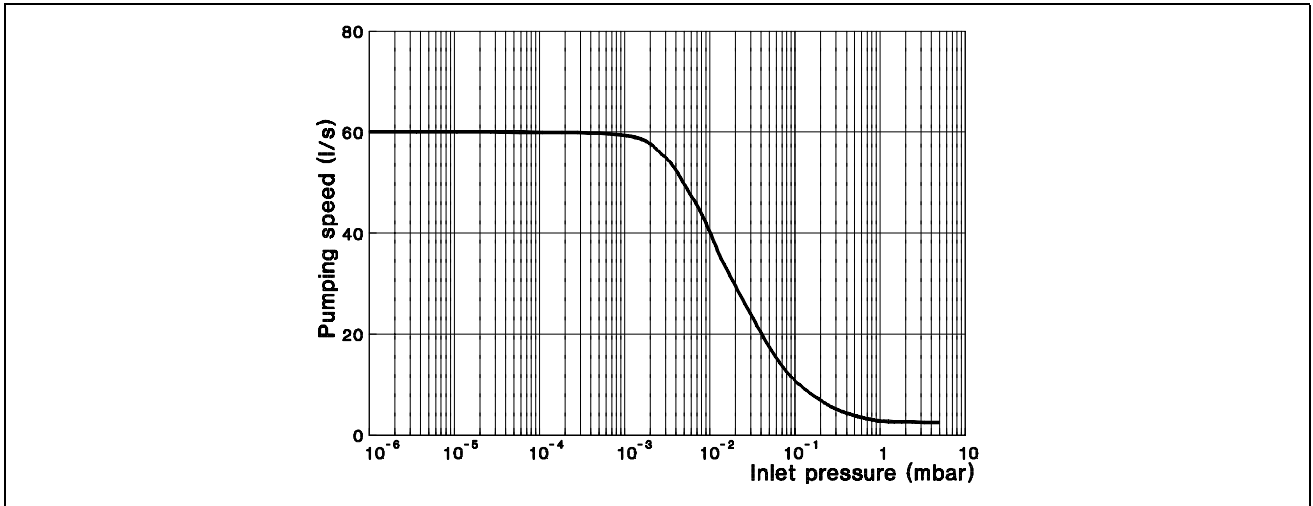

Graph of nitrogen pumping speed against inlet pressure

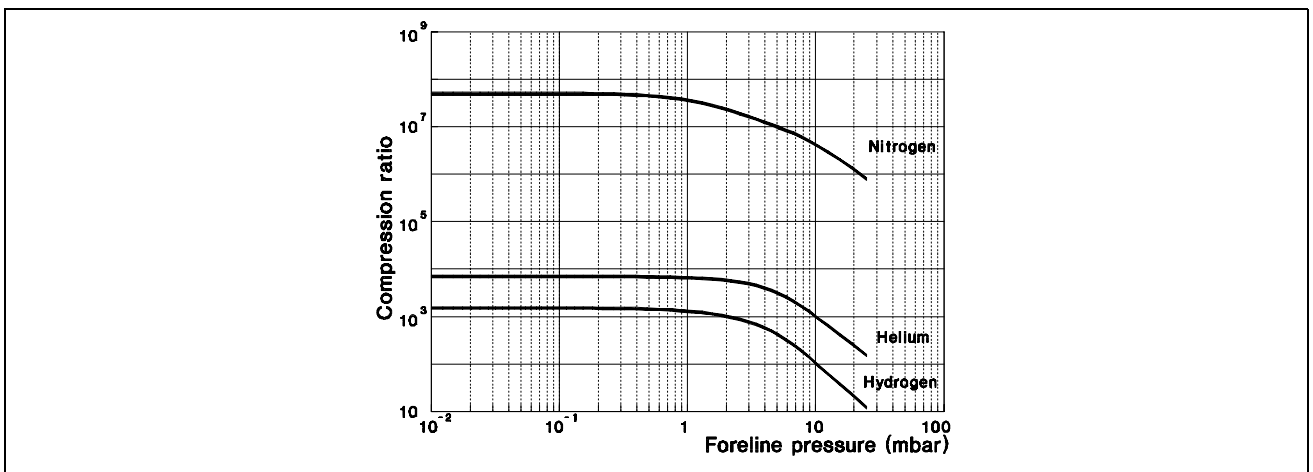

Graph of compression ratio against foreline pressure

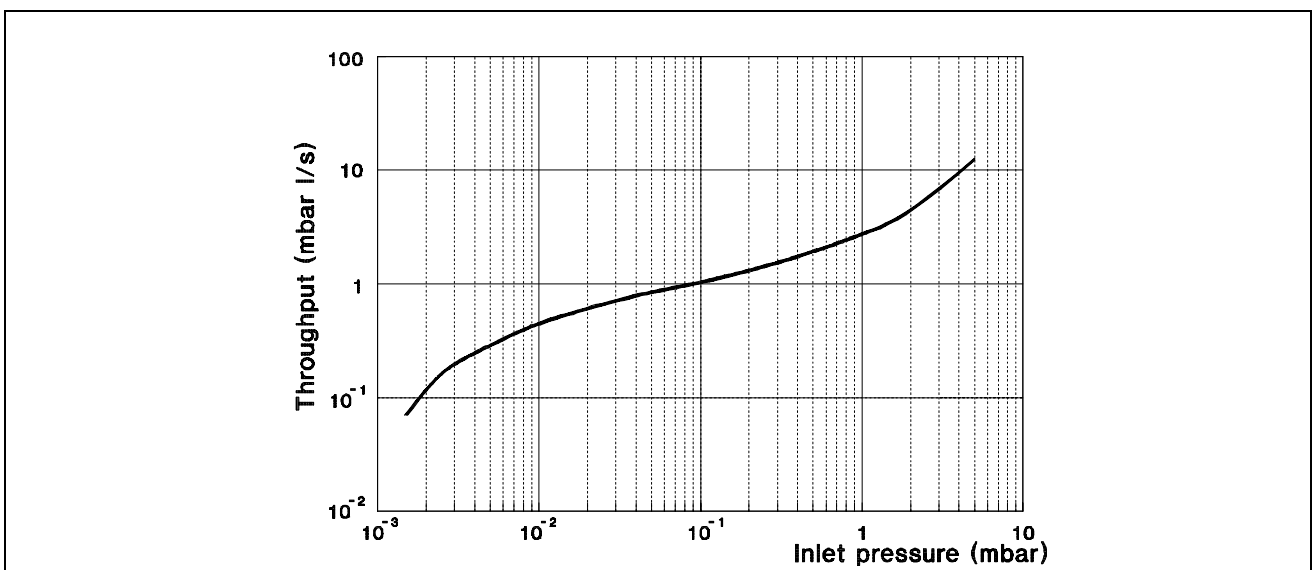

Graph of nitrogen throughput against inlet pressure using the recommended mechanical forevacuum pump

INLET SCREEN INSTALLATION

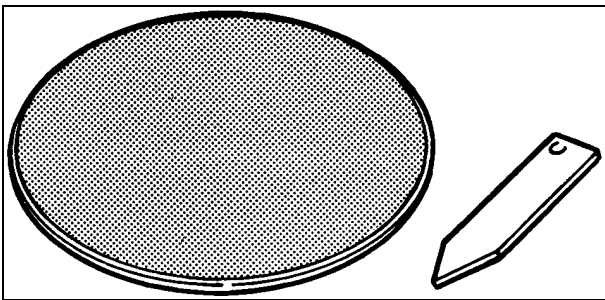

The inlet screens mod. 969-9300 and 969-9309 prevent the blades of the pump from being damaged by debris greater than 0.7 mm diameter.

The inlet screen, however, does reduce the pumping speed by about 10%.

The inlet screen is fitted in the upper part of the pump, as shown in the figure.



The screen can be mounted on either pump series and is supplied with a small tab for easy removal (see figure).

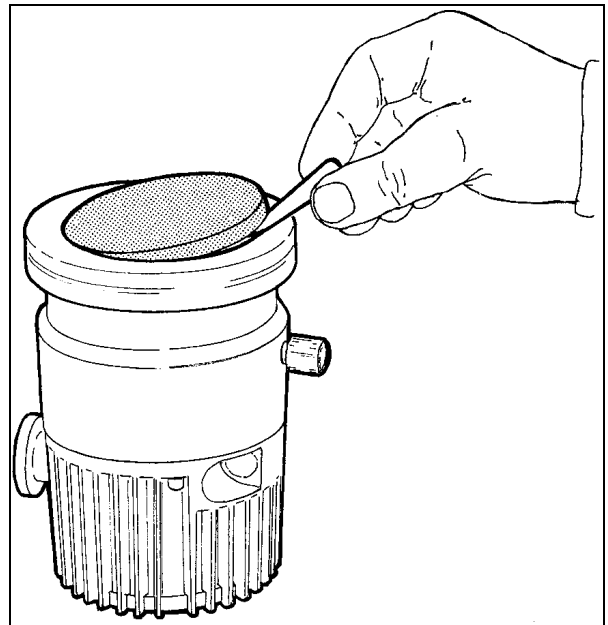

The following figure shows the overall flange dimensions with the protection screen fitted on pump with ISO flange (on the left side) and pump with 4.5" CFF flange (on the right side).

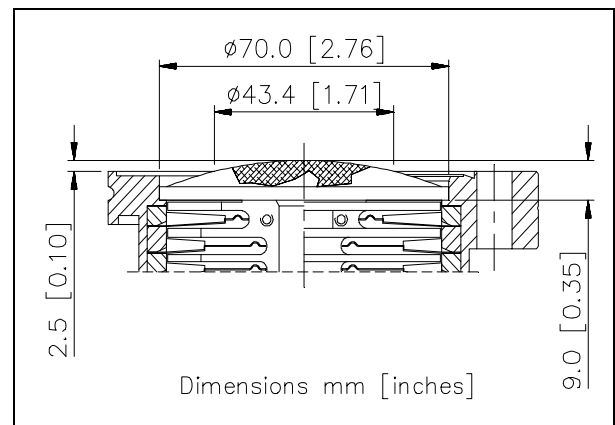

HEATER BAND INSTALLATION

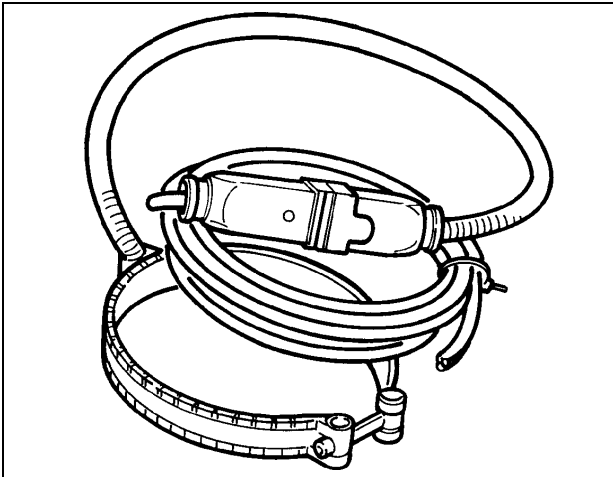

The heater band model 969-9801 and 969-9802 can be used to heat the pump casing when a bakeout is needed.

The heater band is applied to the upper part of the pump envelope, as shown in the figure, and heats it to a temperature of about 80° C.

The heater band must be mounted such that there is perfect thermal contact with the pump wall to obtain fast and efficient heating.

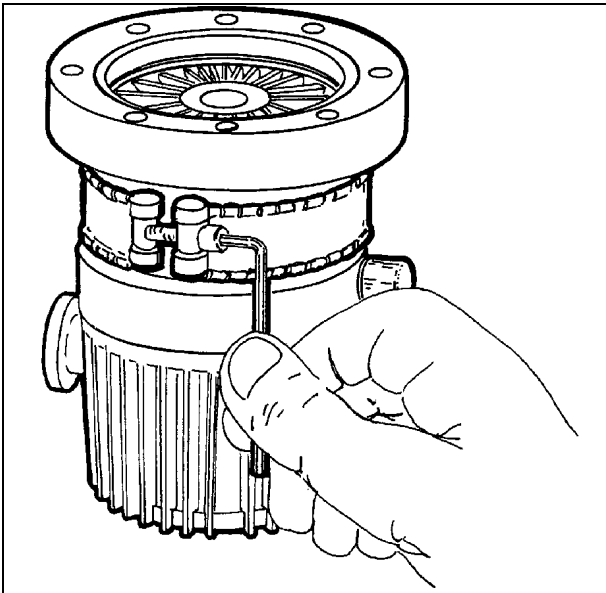

Switch on the heater while the turbopump is in operation. If, for any reason, the turbopump body overheats, it will be automatically cut out by the thermistor sensor.

NOTE

The turbopump must be "baked" only when operating with an inlet pressure less than 10⁻⁴ mbar and with water cooling.

 **CAUTION**

If the chamber of the system is "baked" at a high temperature, a shield should be installed to prevent thermal radiation heating the high vacuum flange on the pump. The maximum temperature allowed for the inlet flange is 120° C.

WATER COOLING KIT INSTALLATION

Two types of water cooling kits are available to be mounted when the pump is used under heavy load conditions or when air cooling is insufficient.

The two model part numbers are: 969-9337 (metallic model), and 969-9347 (plastic model).

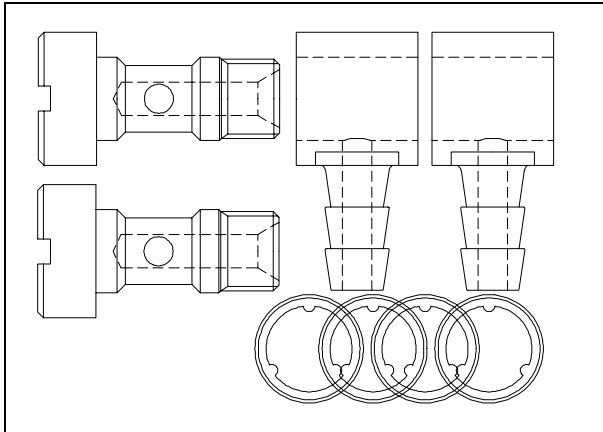

Model 969-9337

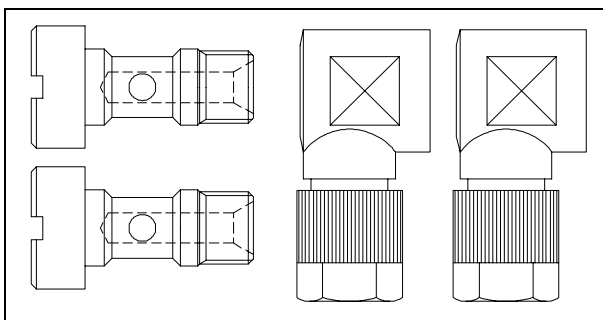

Model 969-9347

CAUTION

The items of the plastic model kit must be assembled as shown in the following figure

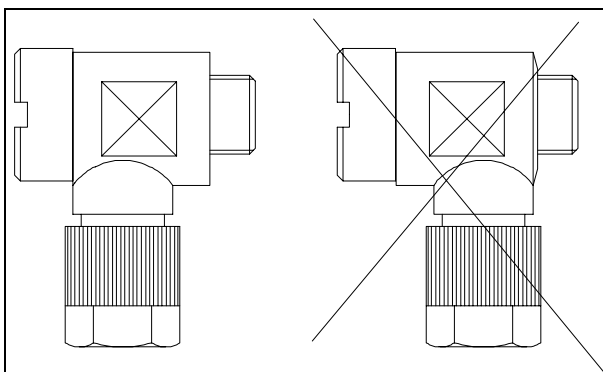

The assembled kit must be screwed into the suitable holes of the pump body with a recommended closing torque of 5 Nm.

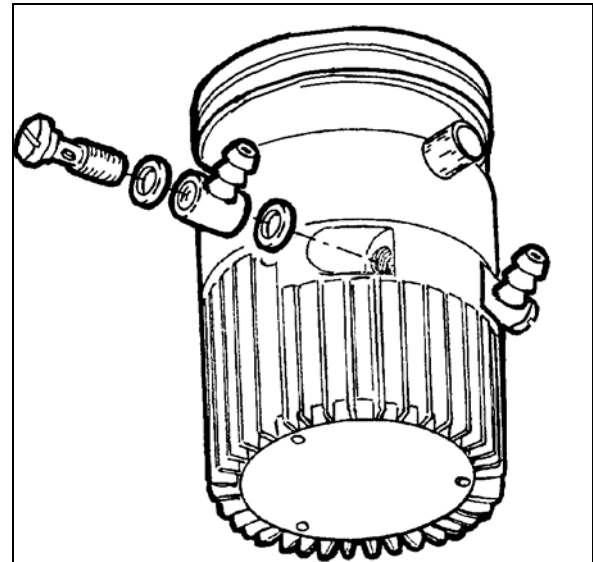

Two 6 mm (1/4") internal diameter rubber or plastic hoses from the water supply must be fitted to the two nozzles.

NOTE

These hoses must be held on the respective nozzles using hose clips to avoid that the tube do not detach during operation.

The plastic model must be screwed into the suitable holes of the pump. Cooling may be carried out either through an open circuit with eventual discharge of the water, or using a closed circuit cooling system.

In both cases, the water temperature must be between +10°C and +30°C, with an inlet pressure between 2 and 4 bar. This allows a flow of about 10 l/h.

NOTE

The water electrical conductance must be $\leq 500 \mu\text{s/cm}$. When the conductance is higher, in closed water circuit, the use of up to 20% of Ethyl-Glycole is suggested.

The overall dimensions with the water cooling kit mounted are shown in the figure.

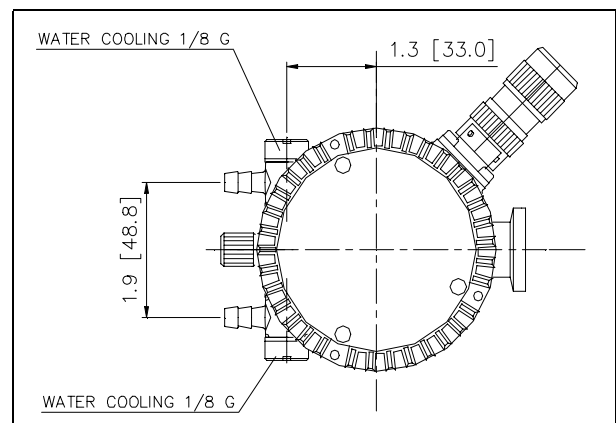

BASE FIXING KIT INSTALLATION

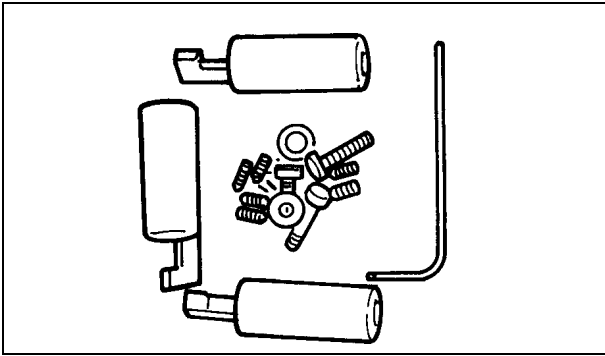

The kit mod. 969-9326 enables the pump to be fixed at the base.

Open the package containing the feet and respective screws.

Insert the three grub screws in the three feed from the rear, as shown in the diagram, and screw them in ensuring that they do not protrude from the other end.

Use the Allen key supplied for this purpose.

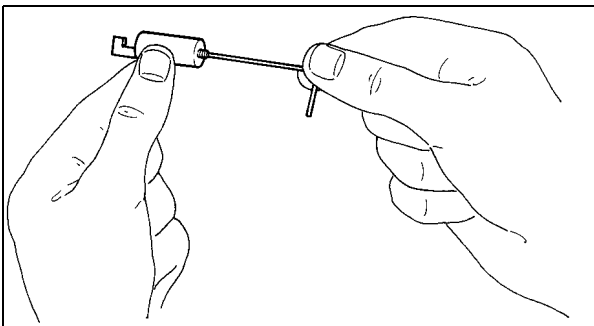

Turn the pump upside down



CAUTION

Before overturning the pump, remove the protection screen, if fitted.

Insert the three feed as shown in the figure, bearing in mind that the position must be as indicated in the figure.

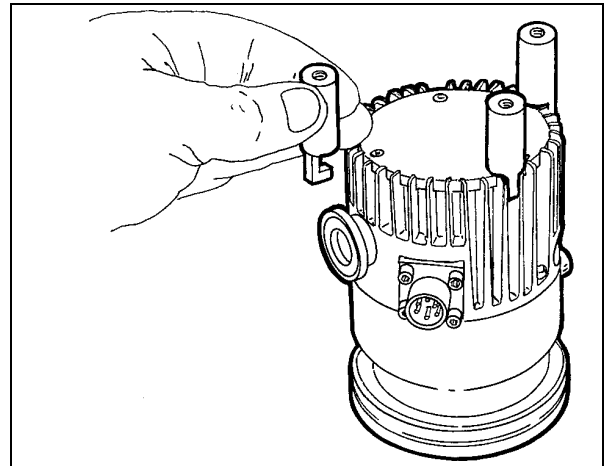

For the feet to the pump by tightening the previously inserted grub screws with the Allen key.

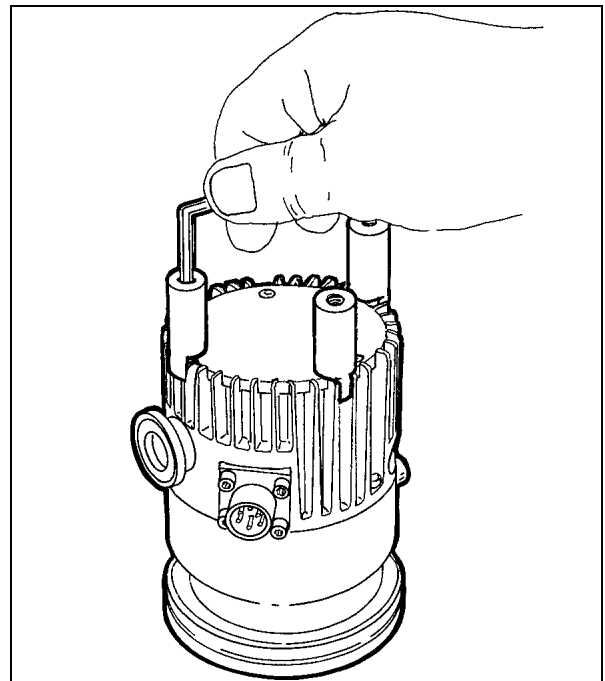

Turn the pump the right way up. Fix the pump to a base by using the three screws provided (M4 thread) in the holes in the three feet.

AIR COOLING KIT INSTALLATION

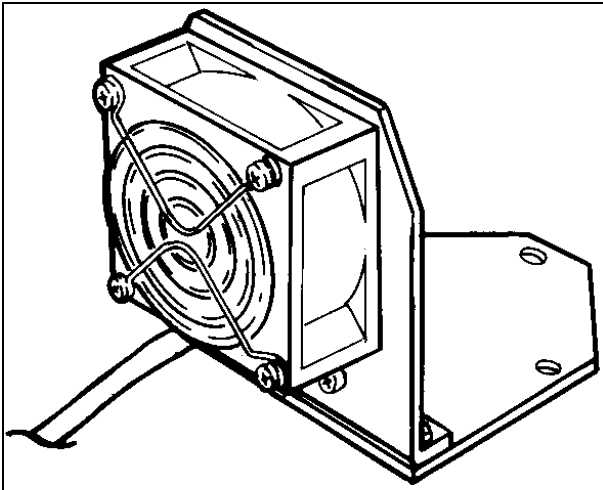

A fan kit model 969-9310 is available for air cooling the pump, when natural air convection is insufficient.

Fan specification:

- air flow: 9 l/s (10 CFM)
 - input voltage: 24 Vdc
 - maximum power: 2.16 W
 - dimensions: 60x60 mm (2.36x2.36 inches)
- Open the package containing the feet and respective screws and install them as indicated in the installation of the base fixing kit.

Position the fan on the pump, ensuring that the holes in the plate line up with those in the feet.

Insert the respective washers and screws and tighten with a screwdriver.

Connect the fan to the controller.

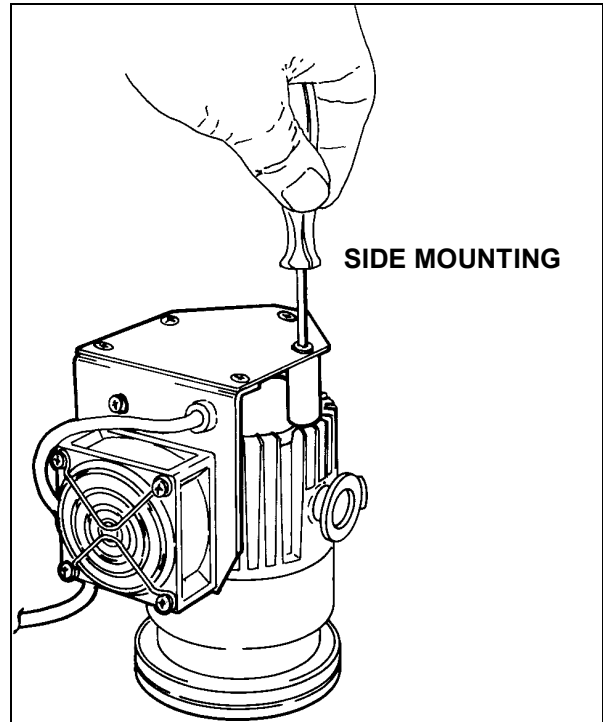

The fan can also be mounted under the pump as shown in the figure.

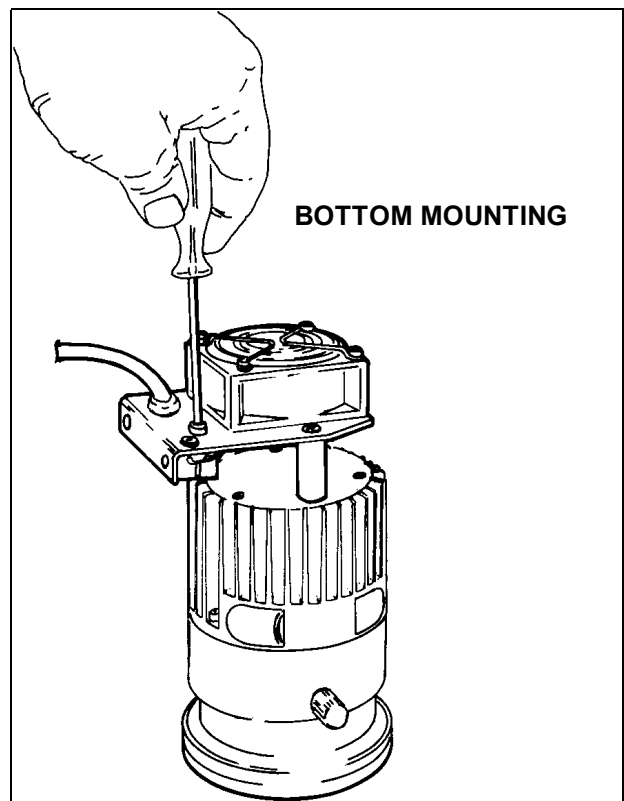

VENT VALVE INSTALLATION

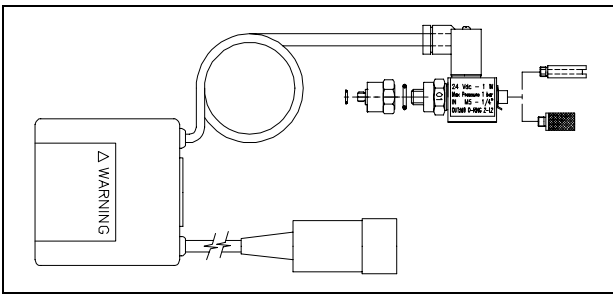

The vent valve mod. 969-9833 enables undesired pump aeration during a temporary power failure (5 sec maximum) to be avoided, and enables an automatic vent operation.

Unscrew the threaded plug.

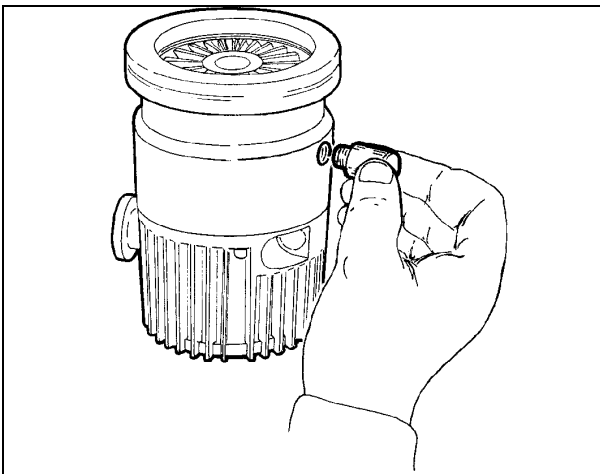

Screw the adapter (1) into the vent hole (2) of the pump.

Fix the valve (3) to the adapter (1).

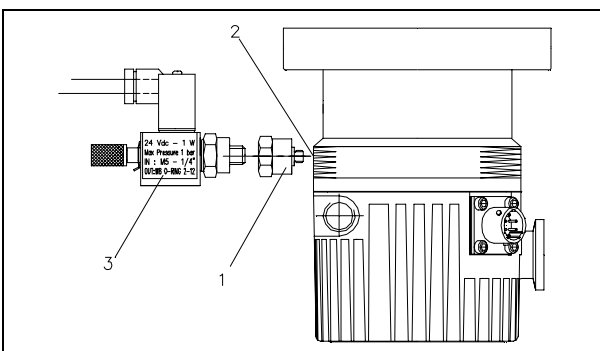

Tighten the valve using a 16 mm hexagonal spanner.

CAUTION

Do not overtighten the valve as this may damage the thread on the pump.

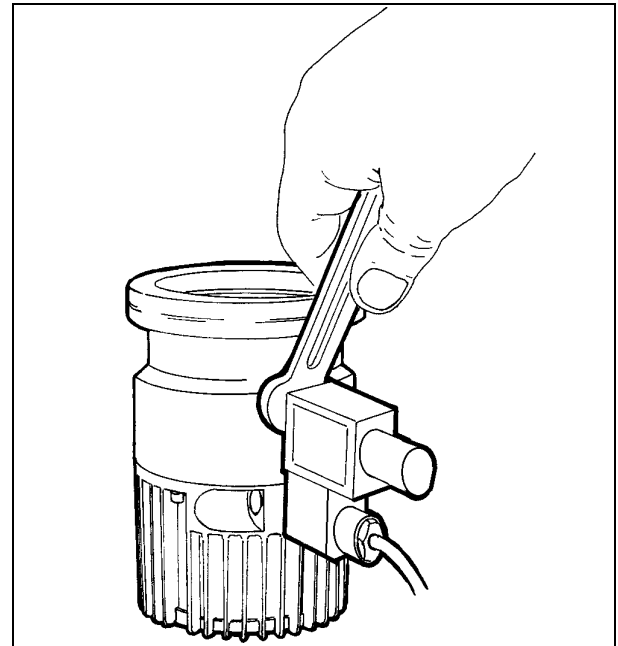

VENT DEVICE INSTALLATION

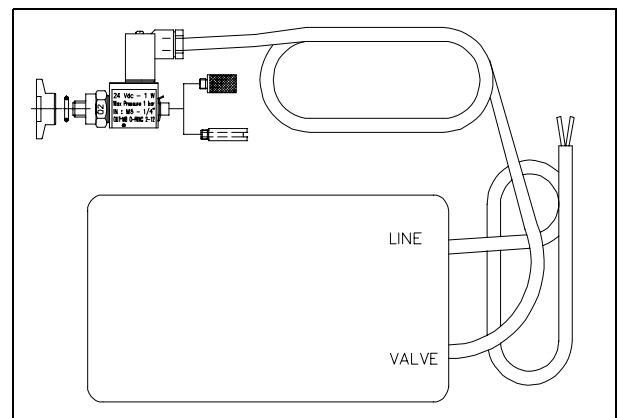

The vent device mod. 969-9831 allows to avoid undesired pump aeration of the pump during a temporary power failure (adjustable time up to 36 min.), and enables an automatic vent operation.

Unscrew and remove the threaded plug.

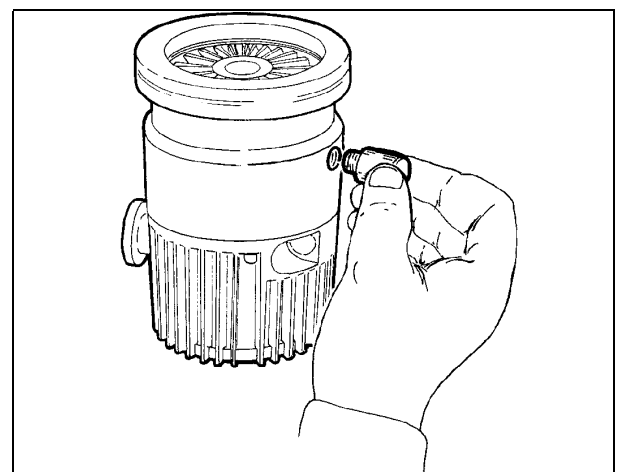

Screw the flange mod. 969-9109 on the pump, taking care of the o-ring right position.

Assemble the seal ring and lock the vent device in position using the KF clamp.

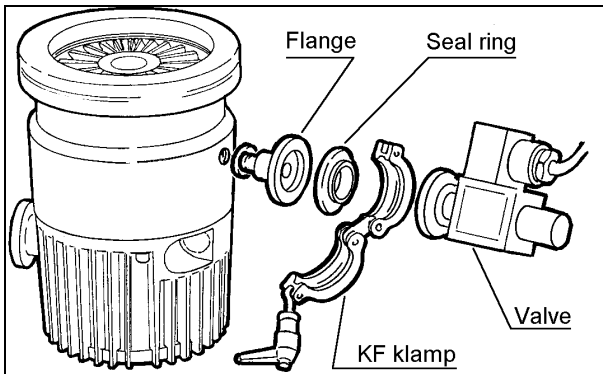

VIBRATION ISOLATOR INSTALLATION

A vibration damper model 969-9340 for ISO 63 inlet flange version pump is available as accessories.

It typically reduces the vibration transmitted from the Turbo-V 70D pump to the system by a factor of 20.

Please refer to the relevant instruction manual.

TYPICAL LAYOUT DIAGRAM

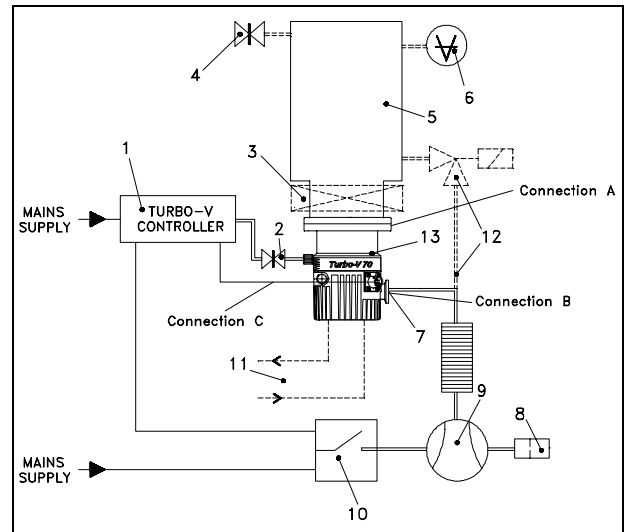

1. Turbo-V controller
2. Vent valve
3. Vacuum pump shut-off valve (optional)
4. System vent valve (optional)
5. Vacuum chamber
6. Ionization gauge
7. Fore-vacuum pump connecting flange
8. Oil mist eliminator
9. Fore-vacuum pump with internal one-way valve
10. Fore-vacuum pump control relay
11. Connection for water cooling
12. Roughing line with valve (optional)
13. Turbopump

Connection A - HIGH VACUUM FLANGE

To connect the Turbo-V70D pump to the ISO inlet flange, remove the outer ring and position the centering ring as shown in the figure.

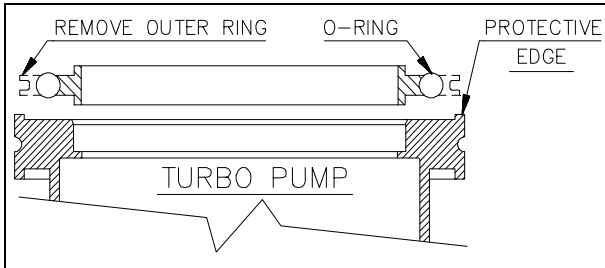

Then fix the two flanges with the clamps or claws as shown in the figure.

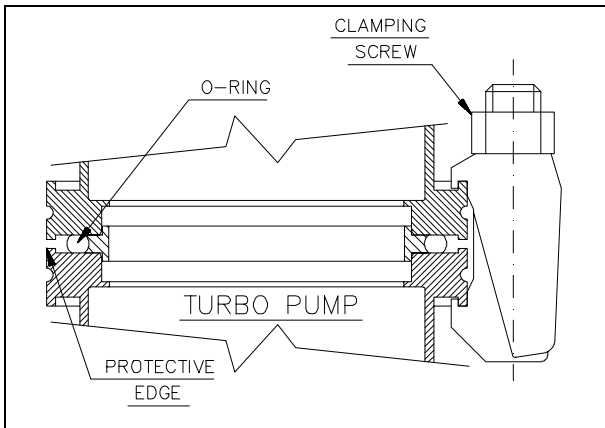

For ConFlat flange connections we recommend using Varian hardware.

To facilitate assembly and dismantling, apply Felpro C-100 high temperature lubricant to the screw threads protruding from the flange and between the nuts and flange. Note that the 2.75" CF flange has six blind holes.

Attach the units and tighten each one in turn. Repeat the sequential tightening until the flange faces meet.

CAUTION

Exercise care when tightening nuts and bolts to avoid creating dents in the envelope as this may cause the pump rotor to lock.

Connection configurations

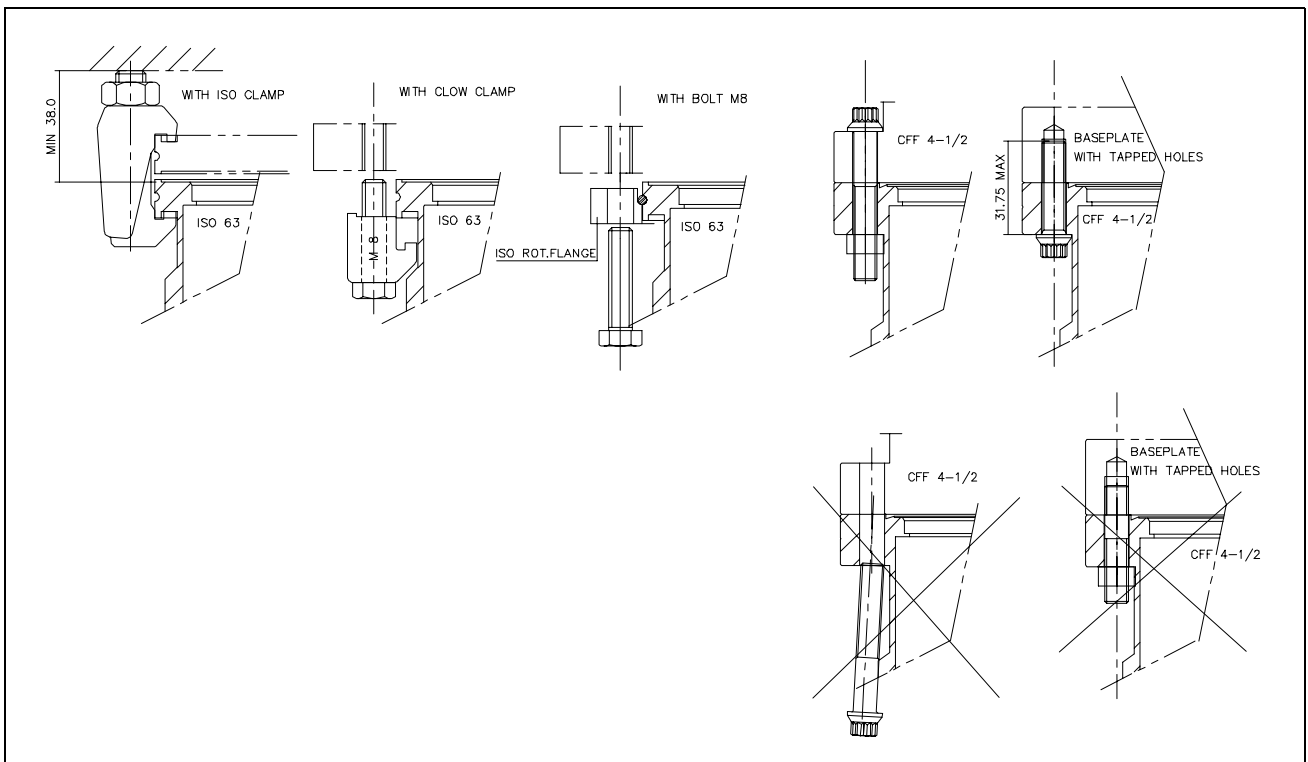

Connection B - FORE-VACUUM PUMP

A flange KF 16 NW is available to connect the Turbo-V 70D to the fore-vacuum pump. A hose or vacuum approved pipe can be used. If a rigid pipe is used, any vibration generated by the mechanical pump must be eliminated through the use of bellows.

NOTE

The Turbo-V 70D is characterised by its high compression ratio also for oil vapors. When using a mechanical oil-sealed pump, it is advisable to install a suitable trap between the turbopump and the fore-vacuum pump in order to prevent oil backstreaming.

Connection C - ELECTRICAL

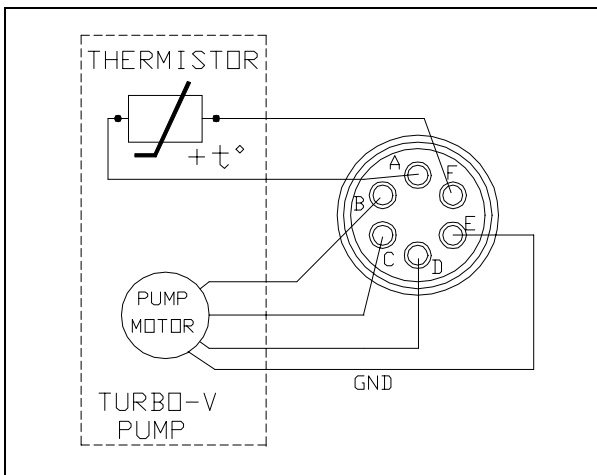

The turbopump is connected to the controller through an 6-pin connector. Pins B, C and D are the 3-phase supply to the motor, pins A and F are connected to the temperature sensor (NTC type, 30 KΩ resistance at 25° C) and pin E is connected to the pump earth.

If the temperature sensor is disconnected, the pump will not start. To prevent damage to the pump when the temperature exceeds 60° C, the sensor automatically cuts out the power supply.

ACCESSORIES

DESCRIPTION	PART NUMBER
Inlet screen DN40	969-9309
Inlet screen DN63	969-9300
Heather band, 120 V	969-9802
Heather band, 220 V	969-9801
Water cooling kit	969-9337
Plastic water cooling kit	969-9347
Air cooling kit	969-9310
Vibration damper, DN 63 ISO	969-9340
Vent valve NW 10 KF	969-9109
Vent valve with fixed delay time	969-9833
Vent valve with adjustable delay time	969-9831
Forepump SD 40, with 1 phase universal motor	P1111-307
Forepump MD 6, 120 V	969-9421
Forepump MD 6, 220 V	969-9422
Base fixing kit	969-9326

For a complete overview of Varian's extensive product lines, please refer to the Varian catalog.



Request for Return



1. A Return Authorization Number (RA#) **WILL NOT** be issued until this Request for Return is completely filled out, signed and returned to Varian Customer Service.
2. Return shipments shall be made in compliance with local and international **Shipping Regulations** (IATA, DOT, UN).
3. The customer is expected to take the following actions to ensure the **Safety** of workers at Varian: (a) Drain any oils or other liquids, (b) Purge or flush all gasses, (c) Wipe off any excess residues in or on the equipment, (d) Package the equipment to prevent shipping damage, (for Advance Exchanges please use packing material from replacement unit).
4. Make sure the shipping documents clearly show the RA# and then return the package to the Varian location nearest you.

North and South America

Varian Vacuum Technologies
 121 Hartwell Ave
 Lexington, MA 02421
 Phone : +1 781 8617200
 Fax: +1 781 8609252

Europe and Middle East

Varian SpA
 Via Flli Varian 54
 10040 Leini (TO) – ITALY
 Phone: +39 011 9979111
 Fax: +39 011 9979330

Asia and ROW

Varian Vacuum Technologies
 Local Office

CUSTOMER INFORMATION

Company name:	
Contact person: Name:	Tel:
Fax:	E-Mail:
Ship Method:	Shipping Collect #: P.O.#:
<i>Europe only:</i> VAT reg. Number:	<i>USA only:</i> <input type="checkbox"/> Taxable <input type="checkbox"/> Non-taxable
Customer Ship To:	Customer Bill To:
.....
.....

PRODUCT IDENTIFICATION

Product Description	Varian P/N	Varian S/N	Purchase Reference

TYPE OF RETURN (check appropriate box)

<input type="checkbox"/> Paid Exchange	<input type="checkbox"/> Paid Repair	<input type="checkbox"/> Warranty Exchange	<input type="checkbox"/> Warranty Repair	<input type="checkbox"/> Loaner Return
<input type="checkbox"/> Credit	<input type="checkbox"/> Shipping Error	<input type="checkbox"/> Evaluation Return	<input type="checkbox"/> Calibration	<input type="checkbox"/> Other

HEALTH and SAFETY CERTIFICATION

Varian Vacuum Technologies **CAN NOT ACCEPT** any equipment which contains **BIOLOGICAL HAZARDS** or **RADIOACTIVITY**. Call Varian Customer Service to discuss alternatives if this requirement presents a problem.

The equipment listed above (check one):

HAS NOT been exposed to any toxic or hazardous materials

OR

HAS been exposed to any toxic or hazardous materials. In case of this selection, check boxes for any materials that equipment was exposed to, check all categories that apply:

Toxic Corrosive Reactive Flammable Explosive Biological Radioactive

List all toxic or hazardous materials. Include product name, chemical name and chemical symbol or formula.

.....

Print Name: Customer Authorized Signature:

Print Title: Date:/...../.....

NOTE: If a product is received at Varian which is contaminated with a toxic or hazardous material that was not disclosed, **the customer will be held responsible** for all costs incurred to ensure the safe handling of the product, and **is liable** for any harm or injury to Varian employees as well as to any third party occurring as a result of exposure to toxic or hazardous materials present in the product.

Do not write below this line

Notification (RA)#: Customer ID#: Equipment #:

FAILURE REPORT

TURBO PUMPS and TURBOCONTROLLERS

<input type="checkbox"/> Does not start <input type="checkbox"/> Does not spin freely <input type="checkbox"/> Does not reach full speed <input type="checkbox"/> Mechanical Contact <input type="checkbox"/> Cooling defective	<input type="checkbox"/> Noise <input type="checkbox"/> Vibrations <input type="checkbox"/> Leak <input type="checkbox"/> Overtemperature	POSITION <input type="checkbox"/> Vertical <input type="checkbox"/> Horizontal <input type="checkbox"/> Upside-down <input type="checkbox"/> Other:	PARAMETERS Power: Rotational Speed: Current: Inlet Pressure: Temp 1: Foreline Pressure: Temp 2: Purge flow: <hr/> OPERATION TIME:
TURBOCONTROLLER ERROR MESSAGE:			

ION PUMPS/CONTROLLERS

<input type="checkbox"/> Bad feedthrough <input type="checkbox"/> Vacuum leak <input type="checkbox"/> Error code on display	<input type="checkbox"/> Poor vacuum <input type="checkbox"/> High voltage problem <input type="checkbox"/> Other
Customer application:	

VALVES/COMPONENTS

<input type="checkbox"/> Main seal leak <input type="checkbox"/> Solenoid failure <input type="checkbox"/> Damaged sealing area	<input type="checkbox"/> Bellows leak <input type="checkbox"/> Damaged flange <input type="checkbox"/> Other
Customer application:	

LEAK DETECTORS

<input type="checkbox"/> Cannot calibrate <input type="checkbox"/> Vacuum system unstable <input type="checkbox"/> Failed to start	<input type="checkbox"/> No zero/high background <input type="checkbox"/> Cannot reach test mode <input type="checkbox"/> Other
Customer application:	

INSTRUMENTS

<input type="checkbox"/> Gauge tube not working <input type="checkbox"/> Communication failure <input type="checkbox"/> Error code on display	<input type="checkbox"/> Display problem <input type="checkbox"/> Degas not working <input type="checkbox"/> Other
Customer application:	

PRIMARY PUMPS

<input type="checkbox"/> Pump doesn't start <input type="checkbox"/> Doesn't reach vacuum <input type="checkbox"/> Pump seized	<input type="checkbox"/> Noisy pump (describe) <input type="checkbox"/> Over temperature <input type="checkbox"/> Other
Customer application:	

DIFFUSION PUMPS

<input type="checkbox"/> Heater failure <input type="checkbox"/> Doesn't reach vacuum <input type="checkbox"/> Vacuum leak	<input type="checkbox"/> Electrical problem <input type="checkbox"/> Cooling coil damage <input type="checkbox"/> Other
Customer application:	

FAILURE DESCRIPTION

(Please describe in detail the nature of the malfunction to assist us in performing failure analysis):

NOTA: Su richiesta questo documento è disponibile anche in Tedesco, Italiano e Francese.
REMARQUE : Sur demande ce document est également disponible en allemand, italien et français.
HINWEIS: Auf Aufrage ist diese Unterlage auch auf Deutsch, Italienisch und Französisch erhältlich.

Sales and Service Offices

Argentina

Varian Argentina Ltd.

Sucursal Argentina
Av. Ricardo Balbin 2316
1428 Buenos Aires
Argentina
Tel: (54) 1 783 5306
Fax: (54) 1 786 5172

Australia

Varian Australia Pty Ltd.

679-701 Springvale Road
Mulgrave, Victoria ZZ 3170
Australia
Tel: (61) 395607133
Fax: (61) 395607950

Benelux

Varian Vacuum Technologies

Rijksstraatweg 269 H,
3956 CP Leersum
The Netherlands
Tel: (31) 343 469910
Fax: (31) 343 469961

Brazil

Varian Industria e Comercio Ltda.

Avenida Dr. Cardoso de Mello 1644
Vila Olimpia
Sao Paulo 04548 005
Brazil
Tel: (55) 11 3845 0444
Fax: (55) 11 3845 9350

Canada

Central coordination through:

Varian Vacuum Technologies
121 Hartwell Avenue
Lexington, MA 02421
USA
Tel: (781) 861 7200
Fax: (781) 860 5437
Toll Free: (800) 882 7426

China

Varian Technologies - Beijing

Room 1201, Jinyu Mansion
No. 129A, Xuanwumen Xidajie
Xicheng District
Beijing 1000031 P.R. China
Tel: (86) 10 6608 1530
Fax: (86) 10 6608 1534

France and Wallonie

Varian s.a.

7 avenue des Tropiques
Z.A. de Courtaboeuf – B.P. 12
Les Ulis cedex (Orsay) 91941
France
Tel: (33) 1 69 86 38 13
Fax: (33) 1 69 28 23 08

Germany and Austria

Varian Deutschland GmbH

Alsfelder Strasse 6
Postfach 11 14 35
64289 Darmstadt
Germany
Tel: (49) 6151 703 353
Fax: (49) 6151 703 302

India

Varian India PVT LTD

101-108, 1st Floor
1010 Competent House
7, Nangal Raya Business Centre
New Delhi 110 046
India
Tel: (91) 11 5548444
Fax: (91) 11 5548445

Italy

Varian Vacuum Technologies

Via F.lli Varian, 54
10040 Leini, (Torino)
Italy
Tel: (39) 011 997 9111
Fax: (39) 011 997 9350

Japan

Varian Vacuum Technologies

Sumitomo Shibaura Building, 8th Floor
4-16-36 Shibaura
Minato-ku, Tokyo 108
Japan
Tel: (81) 3 5232 1253
Fax: (81) 3 5232 1263

Korea

Varian Technologies Korea, Ltd.

Shinsa 2nd Bldg. 2F
966-5 Daechi-dong
Kangnam-gu, Seoul
Korea 135-280
Tel: (82) 2 3452 2452
Fax: (82) 2 3452 2451

Mexico

Varian S.A.

Concepcion Beistegui No 109
Col Del Valle
C.P. 03100
Mexico, D.F.
Tel: (52) 5 523 9465
Fax: (52) 5 523 9472

Taiwan

Varian Technologies Asia Ltd.

18F-13 No.79, Hsin Tai Wu Road
Sec. 1, Hsi Chih
Taipei Hsien
Taiwan, R.O.C.
Tel: (886) 2 2698 9555
Fax: (886) 2 2698 9678

UK and Ireland

Varian Ltd.

28 Manor Road
Walton-On-Thames
Surrey KT 12 2QF
England
Tel: (44) 1932 89 8000
Fax: (44) 1932 22 8769

United States

Varian Vacuum Technologies

121 Hartwell Avenue
Lexington, MA 02421
USA
Tel: (781) 861 7200
Fax: (781) 860 5437
Toll Free: (800) 882 7426

Other Countries

Varian Vacuum Technologies

Via F.lli Varian, 54
10040 Leini, (Torino)
Italy
Tel: (39) 011 997 9111
Fax: (39) 011 997 9350

Internet Users:

Customer Service & Technical Support:

vtt.customer.service@varianinc.com

Worldwide Web Site:

www.varianinc.com/vacuum

Order On-line:

www.evarian.com

Representatives in most countries



VARIAN