

OPERATING INSTRUCTIONS

GA01300_0902

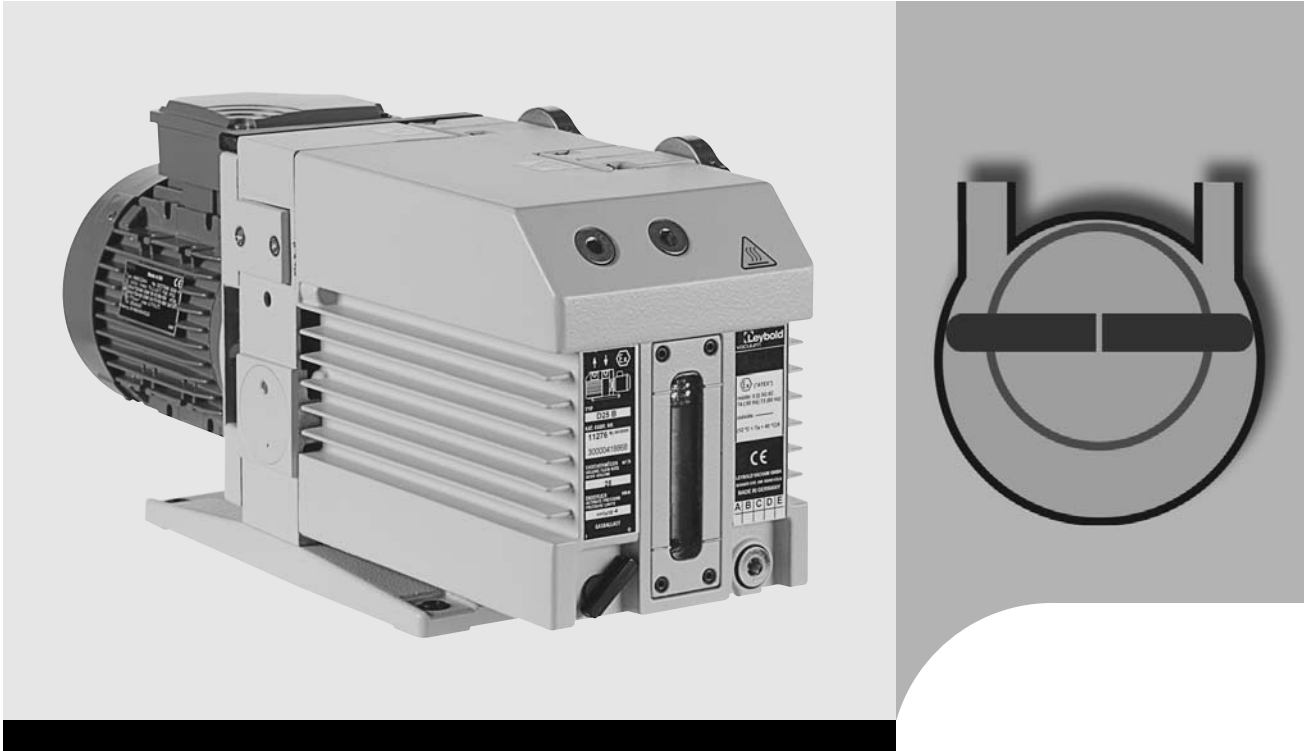

TRIVAC® B D 16 BCS / D 25 BCS

Rotary Vane Vacuum Pump

- with mineral oil
- with PFPE

Part Nos.

113 68/69
113 70/72/78/79
113 80/82
154 50/51



FOR SALES AND SERVICE PLEASE CALL:

PTB SALES T :: 626.334.0500
service@ptbsales.com
www.ptbsales.com

DATE SERVICED: _____

VIEW OUR INVENTORY

Leybold
vacuum

| Section | Page |
|--|-----------|
| Important Safety Information | 3 |
| 1 Description | 6 |
| 1.1 Design and Function | 7 |
| 1.2 Lubricants | 10 |
| 1.3 Supplied Equipment | 11 |
| 1.4 Technical Data | 12 |
| 1.4.1 Motor Dependent Data | 13 |
| 1.5 Accessories | 14 |
| 1.5.1 Standard Accessories and Lubricants | 14 |
| 1.5.2 TRIVAC System | 14 |
| 2 Transport and Storing | 16 |
| 3 Installation | 16 |
| 3.1 Placement | 16 |
| 3.2 Conforming Utilisation | 17 |
| 3.3 Connection to the System | 18 |
| 3.4 Electrical Connections | 20 |
| 3.4.1 Pumps with EExe II T3 Motors | 21 |
| 4 Operation | 22 |
| 4.1 Start-up | 22 |
| 4.2 Operation | 23 |
| 4.2.1 Non-Condensable Gases | 23 |
| 4.2.2 Condensable Gases and Vapours | 23 |
| 4.2.3 Operating Temperature | 24 |
| 4.3 Switching Off / Shutdown | 24 |
| 5 Maintenance | 26 |
| 5.1 Maintenance Plan (Recommendation) | 27 |
| 5.2 Leybold Service | 28 |
| 5.3 Checking the Oil | 28 |
| 5.4 Oil Change | 30 |
| 5.5 Cleaning the Dirt Trap | 32 |
| 5.6 Removing and Fitting the Internal Demister | 32 |
| 5.7 Disassembly and Reassembly of the Electric Motor | 34 |
| 5.8 Replacing the Outer Shaft Seal | 35 |
| 5.9 Removing and Remounting the Pump Module | 38 |
| 6 Troubleshooting | 40 |
| 7 Shelving after Use | 41 |
| 8 Waste Disposal | 42 |
| EC Declaration of Conformity | 43 |
| EC Manufacturer's Declaration | 44 |

Important Safety Information

Indicates procedures that must be strictly observed to prevent hazards to persons.

Warning

Indicates procedures that must be strictly observed to prevent damage to, or destruction of the product.

Caution

Emphasises additional application information and other useful information provided within these Operating Instructions.

Note

The Leybold TRIVAC BCS has been designed for safe and efficient operation when used properly and in accordance with these Operating Instructions. It is the responsibility of the user to carefully read and strictly observe all safety precautions described in this section and throughout the Operating Instructions. The TRIVAC BCS **must only be operated in the proper condition and under the conditions described in the Operating Instructions**. It must be operated and maintained by trained personnel only. Consult local, state, and national agencies regarding specific requirements and regulations. Address any further safety, operation and/or maintenance questions to your nearest Leybold Vacuum office.



Failure to observe the following precautions could result in serious personal injury!

- Before beginning with any maintenance or service work on the TRIVAC BCS (PFPE), disconnect the pump from all power supplies.
- Do not operate the pump with any of the covers removed. Serious injury may result.
- If exhaust gases must be collected or contained, do not allow the exhaust line to become pressurised.
- Make sure that the gas flow from the exhaust port is not blocked or restricted in any way.
- The standard version of the TRIVAC BCS (PFPE) is not suited for operation in explosion hazard areas. For this applications we offer the TRIVAC B ATEX pumps. Contact us before planning to use the pump under such circumstances.
- Before starting up for the first time, the motor circuit must be equipped with a suitable protective motor switch. Please take note of the information in these Operating Instructions or on the electric motor (wiring diagram).

Warning



Safety Information



- The TRIVAC BCS (PFPE) is not suited for pumping of:
 - combustible and explosive gases or vapours
 - radioactive and toxic substances
 - pyrophorous substances.
- Avoid exposing any part of the human body to the vacuum.
- Never operate the TRIVAC BCS (PFPE) without a connected intake line or blank flange.
- The location at which the TRIVAC BCS (PFPE) (including its accessories) is operated should be such that angles over 10° from the vertical are avoided.
- The location of the TRIVAC BCS (PFPE) should be such that all controls are easily accessible.
- Under certain ambient conditions the TRIVAC BCS (PFPE) may attain a temperature of over 80 °C (176 °F). There then exists the danger of receiving burns.
Note the symbols on the pump pointing to the hazards, and in the case of a hot pump wear the required protective clothing.
- The noise level of the TRIVAC BCS (PFPE) is between 57 and 59 dB(A). Introduce suitable hearing protection.
- Before pumping oxygen (or other highly reactive gases) at concentrations exceeding the concentration in the atmosphere (> 21 % for oxygen) it will be necessary to use a special pump. Such a pump will have to be modified and de-greased, and an inert special lubricant (like PFPE) must be used.
- Before operating the TRIVAC BCS (PFPE) with atmospheric gas ballast (optional) check first compatibility with the pumped media so as to avoid hazardous conditions during operation right from the start.
- Before commissioning the TRIVAC BCS (PFPE), make sure that the media which are to be pumped are compatible with each other so as to avoid hazardous situations.
All relevant safety standards and regulations must be observed.
- It is recommended to always operate the TRIVAC BCS (PFPE) with a suitable exhaust line which is properly connected. It must slope down and away from the pump.
- When moving the TRIVAC BCS (PFPE) always use the allowed means. A lifting eye is provided as standard on the pump.

Failure to observe the following precautions could result in damage to the pump!

- Do not allow the ingestion of small objects (screws, nuts, washers, pieces of wire, etc.) through the inlet port. Always use the screen which is supplied with every pump.
- Do not use the pump for applications that produce abrasive or adhesive powders or condensable vapours that can leave adhesive or high viscosity deposits. Please contact Leybold Sales or Service to select a suitable separator. Also please contact Leybold Sales or Service when planning to pump vapours other than water vapour.
- This pump is suited for pumping water vapour within the specified water vapour tolerance limits.
- Avoid vapours that can condense into liquids upon compression inside the pump, if these substances exceed the vapour tolerance of the pump.
- Before pumping vapours, the TRIVAC BCS (PFPE) should have attained its operating temperature, and the gas ballast should be set to position I (position 0 = closed, position I = max. water vapour tolerance, 25 mbar). The pump will have attained its operating temperature about 30 minutes after starting the pump. During this time the pump should be separated from the process, by a valve in the intake line, for example.
- In the case of wet processes we recommend the installation of liquid separators upstream and downstream of the pump as well as the use of the gas ballast.
- The exhaust line should be laid so that it slopes down and away from the pump so as to prevent condensate from back-streaming into the pump.
- The entry of particles and fluids must be avoided under all circumstances.
- Reactive or aggressive substances in the pump chamber may impair the operating oil or modify it. In addition, such substances may be incompatible with the materials of the pump (Viton, grey cast iron, aluminium, steel, resins, glass etc.).
- Corrosion, deposits and cracking of oil within the pump are not allowed.

- Normal amounts of humidity within the range of the pump's vapour tolerance will not significantly affect pump performance when the gas ballast is active.

In the case of custom pumps (with a Part No. deviating from the Part No. stated in the EC Declaration of Conformity) please note the information provided on a separate sheet.

Caution

Note

The references to diagrams, e.g. (1/2) consist of the Fig. No. and the Item No. in that order.

Figures

We reserve the right to modify the design and the specified data. The illustrations are not binding.

Description

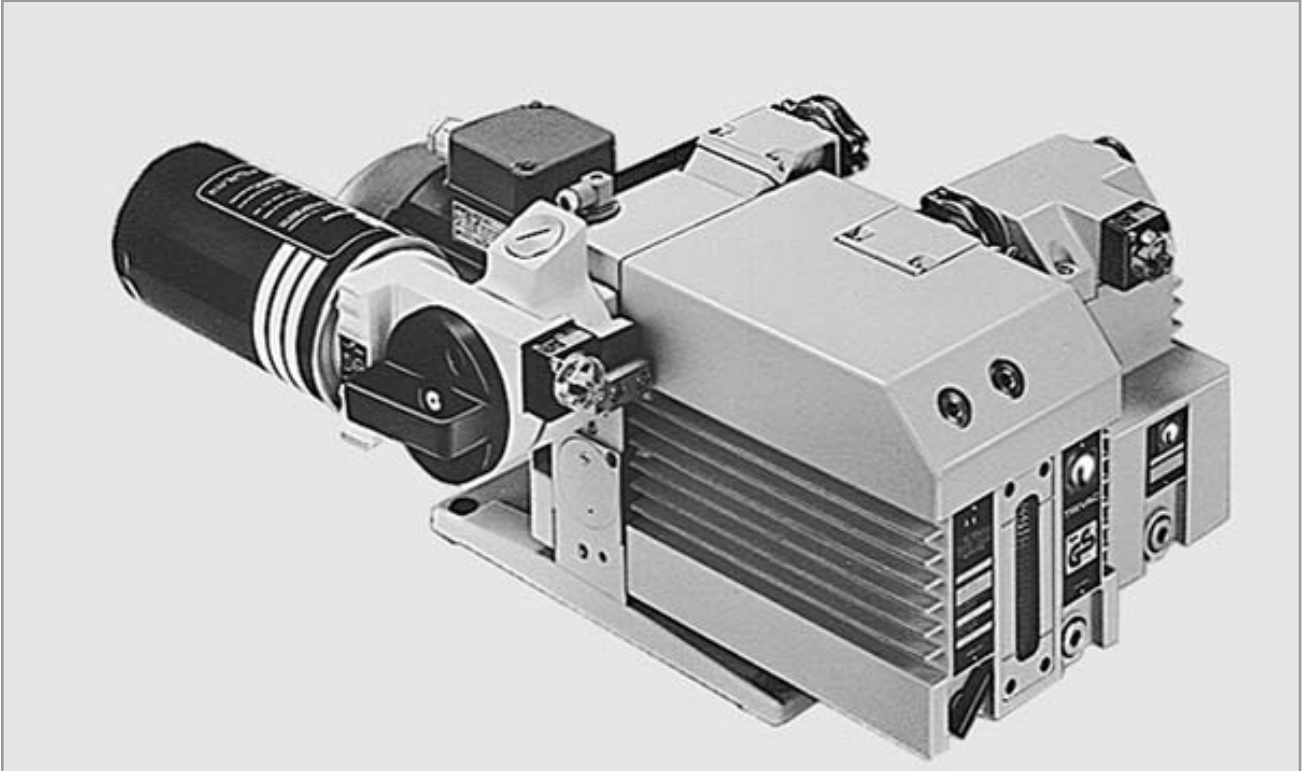

Fig. 1 TRIVAC BCS pump with accessories

1 Description

TRIVAC BCS pumps are oil-sealed rotary vane pumps. The TRIVAC D 16 BCS and D 25 BCS are dual-stage pumps. The number in the type designation (16 or 25) indicates the pumping speed in $\text{m}^3 \cdot \text{h}^{-1}$.

The TRIVAC BCS-PFPE have been prepared especially for operation with perfluoropolyther.

Areas of application

TRIVAC BCS pumps can pump gases and vapours, and evacuate vessels or vacuum systems in the fine vacuum range.

They have been designed particularly for use in connection with corrosive or aggressive media. Moreover, the pump has been prepared for the installation of an electric monitoring facility. Leybold have developed for the TRIVAC BCS a range of accessories which considerably extend the range of applications for this kind of pump. These accessories which in connection with the TRIVAC BCS vacuum pump make up the TRIVAC system, are described briefly in Chapter 1.5.

Drive concept

The drive motor of the TRIVAC BCS is directly flanged to the pump at the coupling housing. The pump and motor shafts are directly connected by a flexible coupling. The bearing points of the pump module are force lubricated sliding bearings.

All controls as well as the oil-level glass and the nameplate are arranged on the front. All connections are to be found at the sides of the pump. The oil-level glass is provided with prisms for better observation of the oil level.

The pump module consists of assembly parts which are pin-fitted so as to allow easy disassembly and reassembly. The pump module can be easily removed without special tools.

Those of standard design are **not** suitable for pumping greater than atmospheric concentrations of oxygen.

Before pumping oxygen (or other highly reactive gases) at concentrations exceeding the concentration in the atmosphere (> 21 % for oxygen) it will be necessary to use a special pump. Such a pump will have to be modified and de-greased, and an inert special lubricant (like PFPE) must be used.

Warning



1.1 Design and Function

The rotor (2/7), mounted eccentrically in the pump housing (2/6), has two radially sliding vanes (2/5) which divide the pump chamber into several compartments. The volume of each compartment changes periodically with the rotation of the rotor.

As a result, gas is sucked in at the intake port (2/1). The gas passes through the dirt trap sieve (2/2), flows past the open anti-suckback valve (2/3) and then enters the pump chamber. In the pump chamber, the gas is passed on and compressed, after the inlet aperture is closed by the vane.

The oil injected into the pump chamber is used for sealing and lubricating. The slap noise of the oil in the pump which usually occurs when attaining the ultimate pressure is prevented by admitting a very small amount of air into the pump chamber.

The compressed gas in the pump chamber is ejected through the exhaust valve (2/10). The oil entrained in the gas is coarsely trapped in the internal demister (2/11); there the oil is also freed of mechanical impurities. The TRIVAC BCS PFPE pumps do not have an internal demister. The gas leaves the TRIVAC BCS-PFPE through the exhaust port.

During compression, a controlled amount of air – the so-called gas ballast – can be allowed to enter the pump chamber by opening the gas ballast valve. The gas ballast stops condensation of vapours in the pump chamber up to the limit of the water vapour tolerance as specified in the technical data for the pump.

The gas ballast valve is opened (position I) and closed (position 0) by turning the gas ballast knob (7/5) on the front.

The gas ballast facility of the TRIVAC BCS pump has been prepared for connecting the inert gas system IGS.

To enable the TRIVAC BCS to be used at intake pressures as high as 1,000 mbar, a special lubricating system was developed featuring force-lubrication of the sliding bearings.

An oil pump (3/6) pumps the oil from the oil reservoir (3/5) into a pressure-lubrication system which supplies oil to all bearing points (3/2). From there the oil enters the pump chamber area (3/4) of the vacuum pump.

Operating principle

Oil filter

Operation with gas ballast

Lubrication system

Description

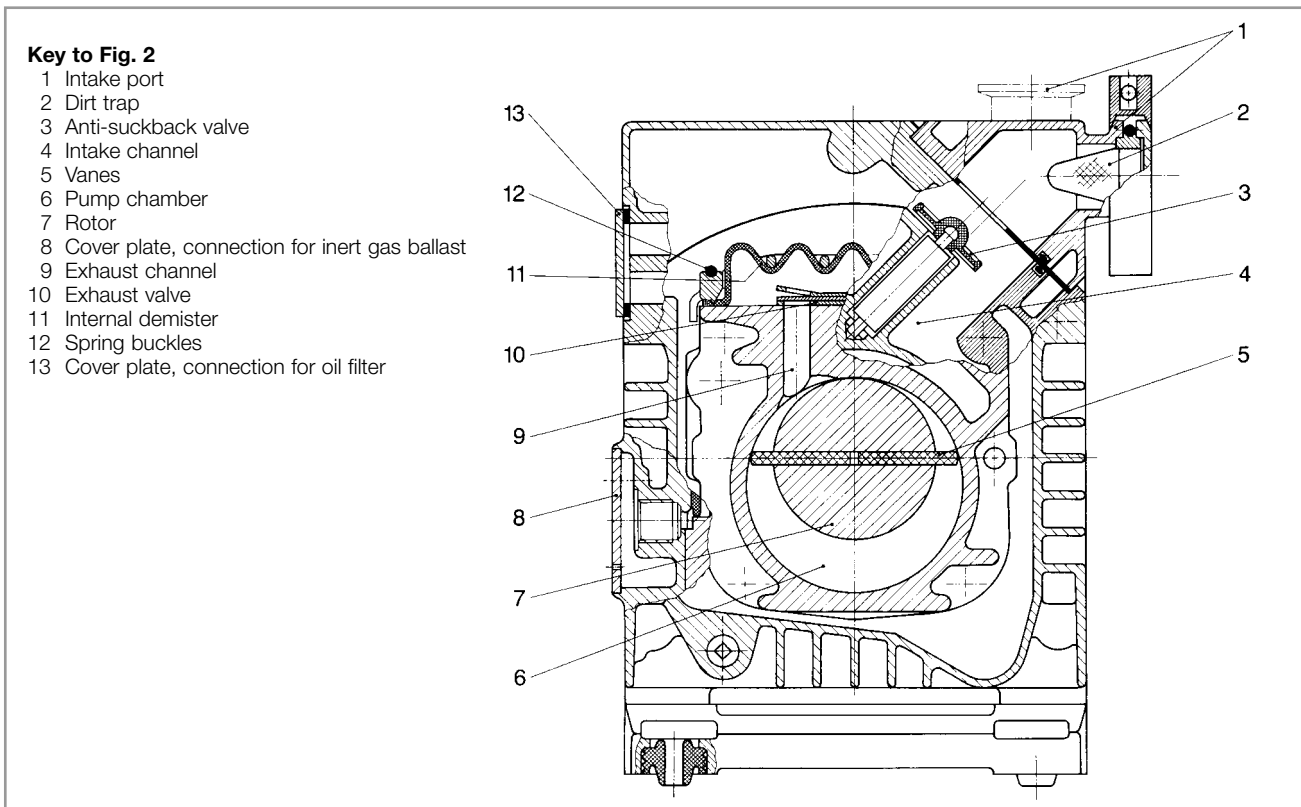

Fig. 2 Sectional drawing of the TRIVAC BCS

The oil pump is fitted in the front end plate on the coupling side of the pump module. The oil suction line is placed low, resulting in a large usable oil reservoir.

Separation of oil and gas

The oil is separated from the gas in the TRIVAC BCS in two steps as described above. First, small droplets are coalesced into large drops in the internal demister (2/11) fitted above the exhaust valve (2/10). Then, the large drops fall into the oil reservoir as the exhaust gas is diverted by the inner walls of the oil case. Thus a low loss of oil is obtained. This and the large usable oil reservoir ensure long intervals between oil changes even at high intake pressures.

Anti-suckback valve

The vacuum is maintained by the TRIVAC BCS through an integrated hydropneumatic anti-suckback valve (2/3) which is controlled via the oil pressure.

During operation of the TRIVAC BCS the control piston (4/3) remains sealed against a spring (4/2) by the oil pressure. The valve disc (4/6) of the anti-suckback valve is held at the lower position by its own weight (valve open). When the pump stops (because it has been switched off or because of a failure), the oil pressure drops and the spring (4/2) presses the control piston (4/3) up. Thus a connection is provided between the oil case or the oil reservoir (4/1) and the piston (4/4) of the anti-suckback valve.

Due to the pressure difference between the oil case and the intake port the oil presses the piston (4/4) up and the valve plate (4/6) against the valve seat (4/5). The quantity of oil in the oil reservoir (4/1) prevents the entry of air into the intake port (2/1) at the beginning of this process.

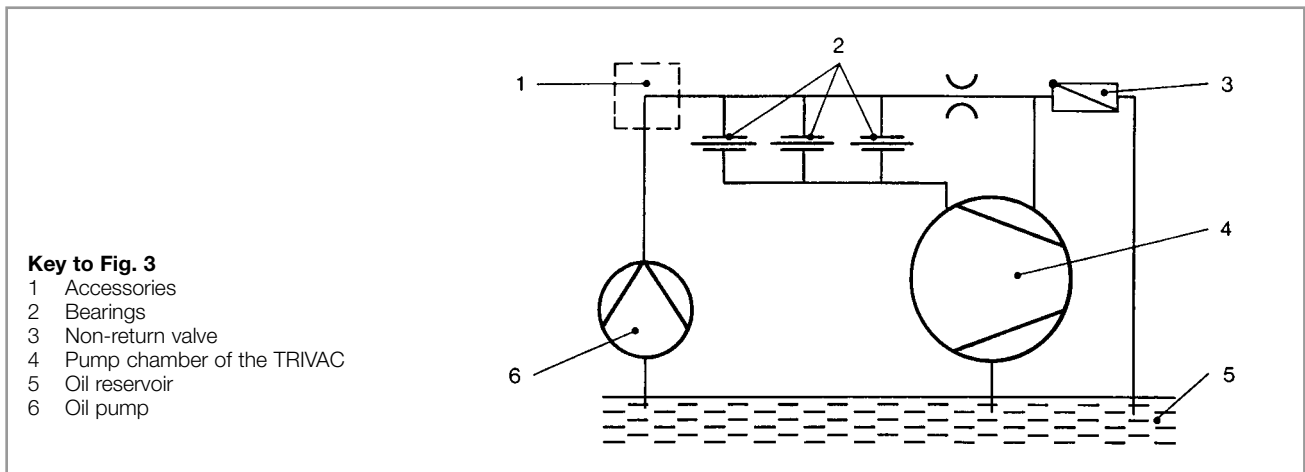

Fig. 3 Schematic of the lubricating system

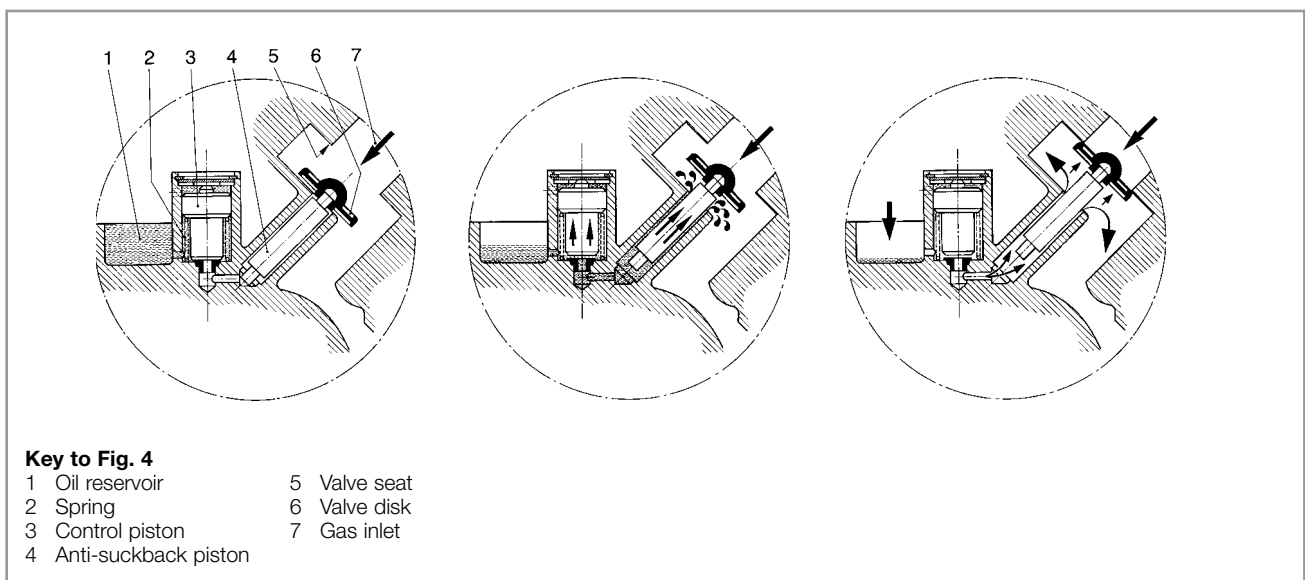

Fig. 4 Hydropneumatic anti-suckback valve

After the oil has flowed out from the reservoir and when the valve plate rests on the valve seat, air follows in, which vents the pump chamber and forces the valve disc (4/6) against its seat. This effectively prevents backstreaming of oil or oil vapours. The anti-suckback valve (2/3) operates independently of the operating mode of the pump, i.e. also with gas ballast.

All aluminium surfaces of the TRIVAC BCS are surface protected and thus particularly capable of resisting aggressive chemicals. A thermocouple has been incorporated in the pump which is used in connection with the optional electrical monitoring facility. The thermocouple may be accessed through the built-in connector (7/8).

Via a second oil fill opening, an exhaust line may be connected for venting the oil case when using the inert gas purging facility.

Surface protection

Thermocouple

1.2 Lubricants

The standard TRIVAC BCS pumps are either ready for operation with mineral oil or with the special lubricant, perfluoropolyther (PFPE).

If mineral oil and PFPE come into contact they will emulsify. That's why the pumps must only be run with the type of lubricant specified for the pump. If you want to change the type of lubricant Leybold should do the change.

In case of operation with mineral oil we recommend our vacuum pump oil N 62.

In case of operation with PFPE we recommend our vacuum pump oil NC 1/14.



Warning

When handling PFPE you should observe the following:

During thermal decomposition at temperatures over 290 °C toxic and corrosive gases are released. When handling PFPE keep it way from open fires. Do not smoke in the work area.

Touch the inner sections of the pumps only while wearing clean gloves, and use clean tools;

Do the necessary work in clean and dry rooms;

After having removed the pump from its packaging, start it up as quickly as possible;

While working on the pump, do not eat, drink or smoke.

As cleaning agents solvents based on hydrofluorether compounds may be used.

Caution

The Operating Instructions GA 07.009 "PFPE for Vacuum Pumps" will be enclosed with all TRIVAC BCS pumps. Observe the handling notes for PFPE collected in these Operating Instructions.

1.3 Supplied Equipment

Pump with motor,

1 centering ring,

1 centering ring with dirt trap,

2 clamping rings DN 25 KF.

Plug without cable to protect the socket for the temperature switch.

For protection during shipment, the connection ports are each blanked off by rubber diaphragms and supporting rings.

The pump is contained with some silica gel in an air-tight plastic bag.

TRIVAC BCS for operation with mineral oil

Upon delivery from Leybold Cologne the pumps will be filled with N62 oil.

TRIVAC BCS for operation with PFPE

The pumps will be supplied without lubricant. However, the pump will still contain residues of the NC 1/14 lubricant. In the D 16 BCS PFPE there will still be about 0.2 litres and in the D 25 BCS PFPE 0.4 litres.

The oil fill plugs have been removed and are supplied separately.

In the case of custom pumps (with a Part No. deviating from the Part No. stated in the EC Declaration of Conformity) please note the information provided on a separate sheet.

Caution

Description

1.4 Technical Data

| TRIVAC BCS | | D 16 BCS two-stage | D 25 BCS two-stage |
|---|--|--|--|
| Nominal pumping speed ¹⁾ | m ³ · h ⁻¹ (cfm) | 18.9 (11.1) | 29.5 (17.4) |
| Pumping speed ¹⁾ | m ³ · h ⁻¹ (cfm) | 16.5 (9.7) | 25.7 (15.1) |
| Ult. partial pr. without gas ballast ¹⁾ | mbar (Torr) | 10 ⁻⁴ (0.75 · 10 ⁻⁴) | 10 ⁻⁴ (0.75 · 10 ⁻⁴) |
| Ultimate total pr. without gas ballast ¹⁾ | mbar (Torr) | < 2 · 10 ⁻³ (< 1.5 · 10 ⁻³) | < 2 · 10 ⁻³ (< 1.5 · 10 ⁻³) |
| Ultimate total pr. with gas ballast ¹⁾ | mbar (Torr) | < 5 · 10 ⁻³ (< 3.8 · 10 ⁻³) | < 5 · 10 ⁻³ (< 3.8 · 10 ⁻³) |
| Water vapour tolerance ¹⁾ | mbar (Torr) | 25 (18.8) | 25 (18.8) |
| Oil filling, min./max. | l | 0.45/1.0 | 0.6/1.4 |
| Connections | DN | 25 KF | 25 KF |
| Motor protection | IP | 55 | 55 |
| Weight * | kg (lbs) | 26 (57.3) | 32 (70.6) |
| Motor power * | W | 550 (750) | 750 |
| Noise level * to DIN 45 635 without/with gas ballast | dB (A) | 52/54 | 52/54 |

TRIVAC BCS with three-phase motor

| | | |
|--|------------------------|------------------------|
| 230/400 V, 50 Hz / 250/440 V, 60 Hz | Part No. 113 68 | Part No. 113 78 |
| 200/346 V, 50 Hz / 208/360 V, 60 Hz | Part No. 113 71 | Part No. 113 81 |
| without motor | Part No. 113 70 | Part No. 113 80 |

| TRIVAC BCS-PFPE | | D 16 BCS-PFPE two-stage | D 25 BCS-PFPE two-stage |
|---|--|--|--|
| Nominal pumping speed ¹⁾ | m ³ · h ⁻¹ (cfm) | 18.9 (11.1) | 29.5 (17.4) |
| Pumping speed ¹⁾ | m ³ · h ⁻¹ (cfm) | 16.5 (9.7) | 25.7 (15.1) |
| Ult. partial pressure without gas ballast ¹⁾ | mbar (Torr) | < 8 · 10 ⁻⁴ (< 6 · 10 ⁻⁴) | < 8 · 10 ⁻⁴ (< 6 · 10 ⁻⁴) |
| Ultimate total pressure with gas ballast ¹⁾ | mbar (Torr) | < 5 · 10 ⁻³ (< 3.8 · 10 ⁻³) | < 5 · 10 ⁻³ (< 3.8 · 10 ⁻³) |
| Ultimate total pressure with reduced gas ballast 200 l · h ⁻¹ ¹⁾ | mbar (Torr) | < 2 · 10 ⁻³ (< 1.5 · 10 ⁻³) | < 2 · 10 ⁻³ (< 1.5 · 10 ⁻³) |
| Lubricant filling min./max. upon delivery | l l | 0,45/1,0 0.2 | 0,6/1,4 0.4 |
| Connections | DN | 25 KF | 25 KF |
| Motor protection | IP | 55 | 55 |
| Weight* | kg (lbs) | 27 (59.5) | 33 (72.8) |
| Motor power* | W | 550 | 750 |
| Noise level* to DIN 45 635, without/with gas ballast | dB (A) | 52/54 | 52/54 |

TRIVAC BCS-PFPE with three-phase motor

| | | |
|--|------------------------|------------------------|
| 230/400 V, 50 Hz / 250/440 V, 60 Hz | Part No. 113 69 | Part No. 113 79 |
| 200/346 V, 50 Hz / 208/360 V, 60 Hz | Part No. 113 73 | Part No. 113 83 |
| 200/400 V, 50 Hz / 200/400 V, 60 Hz | Part No. 154 50 | Part No. 154 51 |
| without motor | Part No. 113 72 | Part No. 113 82 |

1) To DIN 28 400 and subsequent numbers

* Length, weight, motor power and noise level for the models with three-phase motor.

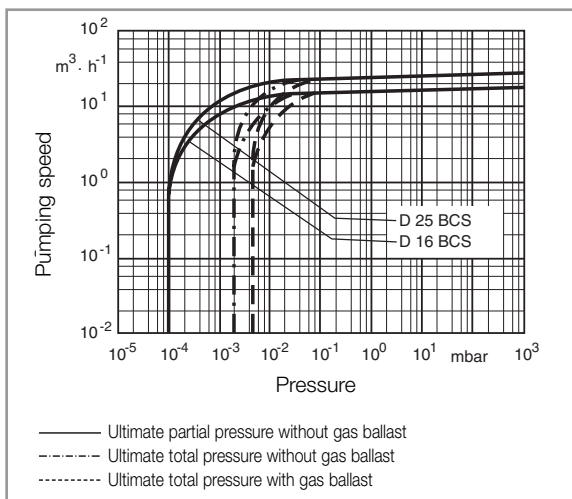

Fig. 5 Pumping speed characteristics for the TRIVAC BCS pumps (50 Hz operation, SI units)

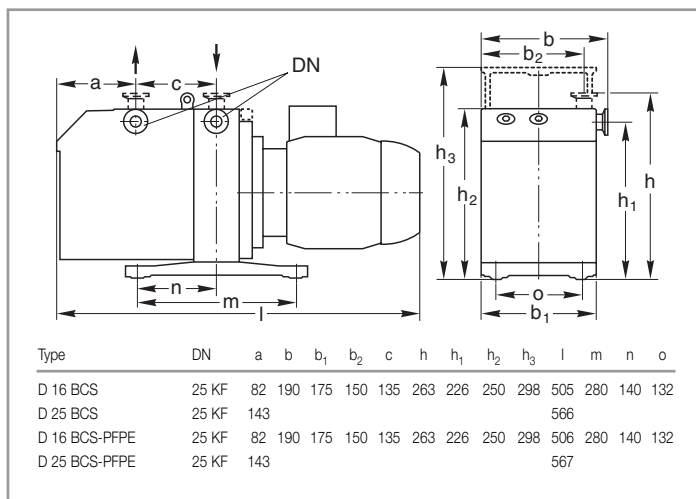

Fig. 6 Dimensional drawings for the TRIVAC BCS pumps (dimensions a, l, b to b₂ and h₁ are approximate, dimensions in mm) (1 inch = 25.4 mm)

1.4.1 Motor Dependent Data

| D 16 BCS | Ref. No. | Nom. voltage (V) | Frequ. (Hz) | Voltage range (V) | Power (kW) | Nom. current (A) | Size | Region |
|------------------------|------------------|--------------------|-------------|------------------------------------|------------|-----------------------|------|--------------|
| Part No. 113 68 | 380 66 001 3~ | 230/400 250/440 | 50 60 | 212-242/380-420 240-277/415-480 | 0.55 | 2.85/1.65 2.5/1.45 | 70 | Euro (USA) |
| D 25 BCS | Ref. No. | Nom. voltage (V) | Frequ. (Hz) | Voltage range (V) | Power (kW) | Nom. current (A) | Size | Region |
| Part No. 113 78 | 380 66 002 3~ | 230/400 250/440 | 50 60 | 218-242/380-420 240-277/415-480 | 0.75 | 3.8/2.2 4.3/2.5 | 80 | Euro (USA) |
| D 16 BCS-PFPE | Ref. No. | Nom. voltage (V) | Frequ. (Hz) | Voltage range (V) | Power (kW) | Nom. current (A) | Size | Region |
| Part No. 113 69 | 380 66 002 3~ | 230/400 250/440 | 50 60 | 218-242/380-420 240-277/415-480 | 0.75 | 3.8/2.2 4.3/2.5 | 80 | Euro (USA) |
| Part No. 154 50 | 100000 807 3~ | 200/400 200/400 | 50 60 | 190-220/380-440 190-240/380-480 | 0.75 | 4,3/2,15 4,0/2,0 | 80 | Wide voltage |
| D 25 BCS-PFPE | Ref. No. | Nom. voltage (V) | Frequ. (Hz) | Voltage range (V) | Power (kW) | Nom. current (A) | Size | Region |
| Part No. 113 79 | 380 66 002 3~ | 230/400 250/440 | 50 60 | 218-242/380-420 240-277/415-480 | 0.75 | 3.8/2.2 4.3/2.5 | 80 | Euro (USA) |
| Part No. 154 51 | 100000 807 3~ | 200/400 200/400 | 50 60 | 190-220/380-440 190-240/380-480 | 0.75 | 4,3/2,15 4,0/2,0 | 80 | Wide voltage |

In the case of custom pumps (with a Part No. deviating from the Part No. stated in the EC Declaration of Conformity) please note the information provided on a separate sheet.

Caution

Motor voltage and current may differ from these data. Observe the data given on the name plates.

Description

1.5 Accessories

1.5.1 Standard Accessories and Lubricants

| | Part No. |
|--|-----------------|
| Separator AK 16-25, DN 40 KF | 188 11 |
| Exhaust filter AF 16-25, DN 40 KF | 189 11 |
| Drain tap for condensate trap, exhaust filter, oil drain of the pump, vacuum-tight | 190 90 |
| Exhaust filter with lubricant return AR 16-25 | 189 21 |
| Dust filter | 186 10 |
| Dust separator | 186 11 |
| Fine vacuum adsorption trap (with zeolite) | 187 10 |
| Adsorption trap (with aluminium oxide) | 854 15 |
| Oil filter OF 4-25 | 101 91 |
| Chemical filter CF 4-25 | 101 96 |
| Oil N 62 1 l | 177 01 |
| 5 l | 177 02 |
| 20 l | 177 03 |
| (Order through Leybold Cologne, Germany) | |
| NC 1/14 1 l | 177 38 |
| HE-1600 1 lb | 898 565 |
| (Order through LHVP, Export, Pa, USA) | |

Special oils upon request.

Caution Use only the kind of oil specified by Leybold. Alternative types of oil upon request.

1.5.2 TRIVAC System

Leybold has developed the TRIVAC system especially for processes which depend on the reliability of the pump under difficult conditions (pumping of aggressive gases or vapours, for example).

Moreover, the pump status may be monitored continuously through visual and electric indicators.

The TRIVAC system consists of the TRIVAC BCS pump and the following accessories:

CFS 16-25 chemical filter w. safety separating valve**Part No. 101 76**

The CFS is a main flow lubricant filter incorporating a safety separating valve which may be exchanged while the pump continues to operate. The status of the interchangeable filters is indicated.

ARS 16-25 exhaust filter with lubricant return**Part No.: 189 56**

The ARS filter collects the droplets of lubricant entrained in the exhaust gas and returns the collected lubricant back into the pump by means of a float controlled valve. This reduces the consumption of lubricant by the pump to an insignificant level so that a daily oil check will no longer be necessary. The status of the filter element may be checked at any time through the differential pressure indicator.

IGS 16-25 inert gas system**Part No.: 161 76**

This accessory which may be controlled through a solenoid valve allows the definite injection of controlled quantities of gas into the TRIVAC BCS.

Thus it offers the possibility of effectively reducing contaminants in the lubricant of the system and the materials of the system itself.

LSS 16-25 limit switch system**Part No.: 161 06**

This accessory consists of a package of limit switches and serves the purpose of monitoring the operation of the system.

Included with the limit switch system are one each:

- oil pressure switch (operating pressure)
- float switch (oil level monitoring)
- flow switch (inert gas)
- differential pressure switch (chemical filter)
- pressure switch (exhaust filter)
- connection cable for the built-in temperature switch

EIS 16-25 electrical indicator system**Part No.: 160 96**

This accessory combines all switch status signals and indicates the status of these switches through LEDs: "GREEN" for normal operation, "RED" for fault. Through a multi-way connector all signals may be accessed for transmission to a remote processing unit.

2 Transport and Storing

Caution

- Pumps which are filled with operating agents must only be moved while standing upright. Otherwise oil may escape. Avoid any other orientations during transport.

Warning



- Check the pump for the presence of any oil leaks, since there exists the danger that someone may slip on spilt oil.
- When lifting the pump you must make use of the crane eyes provided on the pump for this purpose; also use the recommended type of lifting device.

3 Installation

3.1 Placement

Warning



The standard pump is not suited for installation in explosion hazard areas. When planning such an application please contact us first.

The TRIVAC BCS pump can be set freely up on a flat, horizontal surface. Rubber feet under the coupling housing ensure that the pump can not slip.

If you wish firmly install the pump in place, insert bolts or similar through the bore holes in the rubber feet.

The rubber feet act as vibration absorbers. They must therefore not be compressed by bolts.

When installing the TRIVAC BCS pump, make sure that the connections and controls are readily accessible.

Max. tilt for the pump (without further attachment) with possibly fitted standard accessories is 10° from the vertical.

Ambiant conditions

The site chosen should allow adequate air circulation to cool the TRIVAC BCS (keep front and rear unobstructed). The ambient temperature should not exceed +40 °C (104 °F) and not drop below +12 °C (55 °F).

The max. amount of heat given off approximately corresponds to the rated motor power.

3.2 Conforming Utilisation

TRIVAC BCS pumps are oil-sealed rotary vane pumps.

The TRIVAC BCS-PFPE have been prepared especially for operation with perfluoropolyther.

TRIVAC BCS pumps can pump gases and vapours, and evacuate vessels or vacuum systems in the fine vacuum range. They have been designed particularly for use in connection with corrosive or aggressive media.

They are not suited for operation in explosion hazard areas.

The TRIVAC BCS (PFPE) is not suited for pumping of:

- combustible and explosive gases or vapours
- radioactive and toxic substances
- pyrophorous substances.

TRIVAC BCS of standard design are **not** suitable for pumping greater than atmospheric concentrations of oxygen.

Before pumping oxygen (or other highly reactive gases) at concentrations exceeding the concentration in the atmosphere (> 21 % for oxygen) it will be necessary to use a special pump. Such a pump will have to be modified and de-greased, and an inert special lubricant (like PFPE) must be used.

The pumps are not suitable for pumping of liquids or very dusty media. Suitable protective devices must be installed.

Caution

Our technical sales department is available for further advice in these matters.

3.3 Connection to the System

Warning



When operating the pump with PFPE observe the additional information provided in Chapter 1.2 and Operating Instructions GA 07.009.

Remove and retain the shipping seals

Before connecting the TRIVAC BCS, remove the shipping seals from the connection flanges (7/2) and (7/3).

Retain the shipping seals in case you need to store the pump in the future.

The pump is shipped with intake and exhaust flanges mounted for horizontal connection of the connecting lines. You can easily convert the ports for vertical connection by removing the four capscrews, rotating the flanges as required, and reinstalling the capscrews. Connect the intake and exhaust lines with a centering ring and a clamping ring each. Use the centering ring with dirt trap for the intake port.

without strain

Connect the intake and exhaust line using anti-vibration bellows, without placing any strain on the pump.

clean

The intake line must be clean. Deposits in the intake line may outgas and adversely affect the vacuum. The connecting flanges must be clean and undamaged.

The maximum throughput of the pump is equivalent to the pumping speed of the pump.

Minimum cross-section

The cross-section of the intake and exhaust lines should be at least the same size as the connection ports of the pump. If the intake line is too narrow, it reduces the pumping speed. If the exhaust line is too narrow, overpressures may occur in the pump; this might damage the shaft seals and cause oil leaks. The maximum pressure in the oil case must not exceed 1.5 bar (absolute).

Maximum pressure

When pumping vapours, it is advisable to install condensate traps on the intake and exhaust sides.

Prevent condensate from flowing back

Install the exhaust line with a **downward slope** (lower than the pump) so as to prevent condensate from flowing back into the pump. If this is not possible, insert a condensate trap.

When oil mist is to be removed from the exhaust flow we recommend the use of the exhaust filter with lubricant return (ARS) which is part of the TRIVAC system.

When pumping aggressive media in particular in connection with PFPE as the lubricant, we recommend the use of the chemical filter with safety separating valve (CFS) which is part of the TRIVAC system. This will considerably extend the service life of the lubricant.

The inlet pressure for the gas ballast should be about 1000 mbar (absolute) and sufficient quantities of gas must be available (about $\frac{1}{10}$ of the pumping speed).

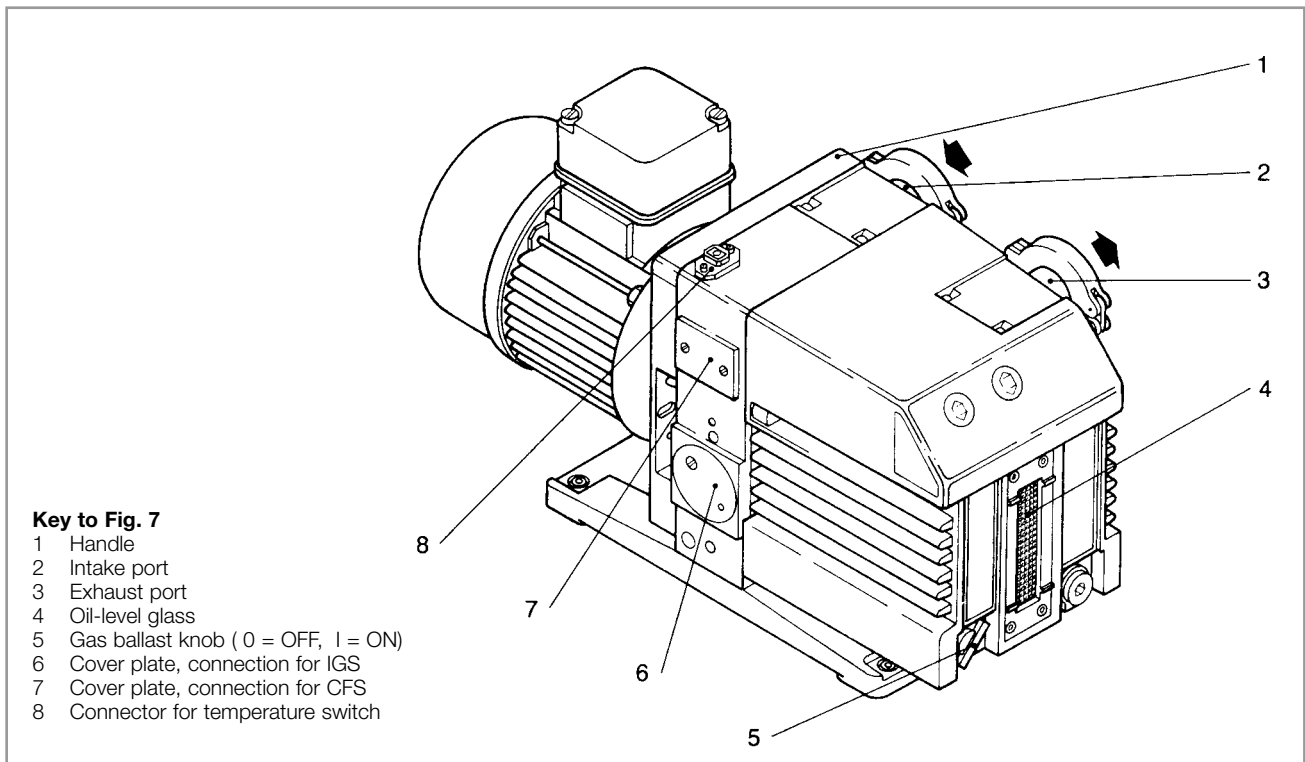

Fig. 7 Connections and controls

Never operate the pump with a sealed exhaust line. There is the danger of injury.

Before starting any work on the pump, the personnel must be informed about possible dangers first. All safety regulations must be observed.

Depending on the type of application or the kind of pumped media, the corresponding regulations and information sheets must be observed.

Warning



3.4 Electrical Connections

Warning



Before wiring the motor or altering the wiring, ensure that mains supply for the pump is off and that it can not be applied inadvertently.

In order to prevent the pump from running up unexpectedly after a mains power failure, the pump must be integrated in the control system in such a way that the pump can only be switched on again manually. This applies equally to emergency cut-out arrangements.

The connections must only be provided by a trained electrician or must be supervised by a trained electrician working in accordance with the currently valid IEC (International), EN (European) or national guidelines.

Observe all safety regulations.

TRIVAC BCS pumps are supplied with three-phase motor but without accessories for electrical connection. They must be connected via the appropriate cable, and a suitable motor protection switch.

Set the switch in accordance with the rating on the motor nameplate.

Fig. 8 shows the connection for pumps with 230/380 V, 50 Hz motors. In the case of pumps equipped as standard with a 60 Hz motor, please observe the diagram on or at the motor.

Check the direction of rotation

After connecting the motor and after every time you alter the wiring, check the direction of rotation. To do so, briefly switch on the motor and check whether a suitable cover (e. g. a blank flange) is sucked on at the intake port. If not, interchange two phases of the connection.

Observe the direction arrow on the coupling housing.

If the connector for the temperature switch is not used, the plug may remain connected at this socket to protect it. However, there is the danger that the protruding plug may be damaged.

Temperature switch

The built-in temperature switch provides a signal when the pump gets too hot. We recommend that you access the signal available at this connector through the LSS and the EIS. Otherwise you may access the signal at pins 1 and 2 (voltage 24 V DC max., power consumption 10 W).

In the case of custom pumps (with a Part No. deviating from the Part No. stated in the EC Declaration of Conformity) please note the information provided on a separate sheet.

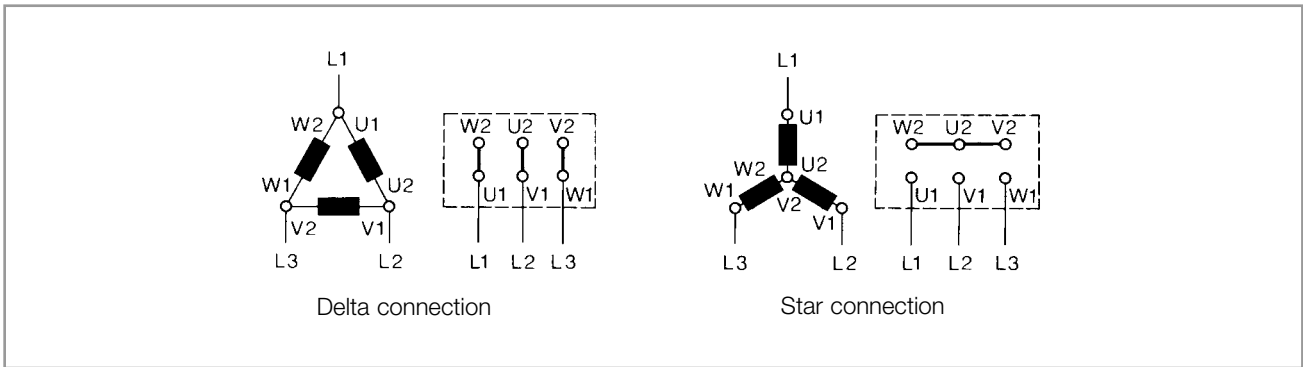

Fig. 8 Connection diagram for TRIVAC BCS with 50 Hz 3-phase motor

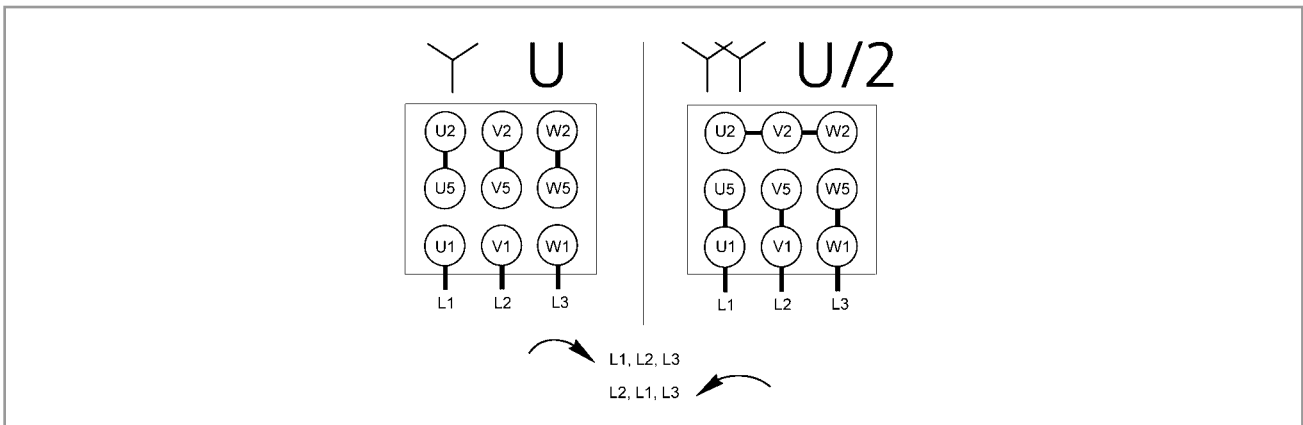

Fig. 8a Double star - Connection for pumps with 190-220 V, 50 Hz and 190-240 V, 60 Hz motor (Part No. 154 50/51)

3.4.1 Pumps with EExe II T3 Motors

There are no reservations as to operation of the vacuum pump in explosion hazard areas of outer ZONE 1 for substances of temperature classes T1 to T3 and explosion group IIA and IIB when observing the conditions given in the following:

The electric motor of the vacuum pump must be connected through a suitable motor protection switch to the mains supply. If the vacuum pump is supplied ready for connection, the motor protection switch needs to be installed by the customer on the vacuum pump and within a pressure-tight encapsulation.

Warning



The electric motor must be installed in accordance with the accepted rules which apply to electrical systems in explosion hazard areas. If required, detailed information on this is available from the manufacturer.

In case of a failure relating to the vacuum, the vacuum pump must be switched off automatically by interrupting the power supply.

Due to the measures introduced, the vacuum pump is **not** suited for pumping explosive atmospheres (inner explosion protection). If planning such an application please consult us first.



4 Operation

4.1 Start-up

Warning



Each time before starting up check the oil level.

Open all valves blocking the exhaust lines. The pump must never be operated with a blocked or constricted exhaust line.

For pumps with 3-phase motors, check the direction of rotation before starting the pump for the first time and after each change in the electrical connection (see Chapter 3.4).

On initial start-up, after prolonged idle periods or after an oil change, the specified ultimate pressure cannot be attained until the oil is degassed.

Run-up phase

This can be done by running the pump for approx. 30 min. with the intake line closed and the gas ballast valve (7/5) open.

If the chemical filter (CFS) has been installed on the pump the separating valve may be set to the position marked "Wechsel" during the first part of the run-up phase. When doing so, the relatively cold and thick lubricant will not have to be pumped through the interchangeable filter, thus removing some load from the pump's motor. Thereafter, the separating valve is set to the position "Betrieb".

Warning



Before starting the pump ensure that the pump and the fitted accessories meet the requirements of your application and that safe operation can be guaranteed.

Avoid exposure of any part of the body to the vacuum. There is the danger of injury. Never operate the pump with an open intake port. Vacuum connections as well as oil-fill and oil-drain openings must never be opened during operation.

The safety regulations which apply to the application in each case must be observed. This applies to installation, operation and during maintenance (service) as well as waste disposal and transportation.

The standard pump is not suited for pumping of hazardous gases or vapours.

Our technical sales department is available for further advice in these matters.

4.2 Operation

TRIVAC BCS pumps can pump condensable gases and vapours, provided that the gas ballast valve (7/5) is open and the pump has attained its operating temperature.

In connection with the inert gas system (IGS) which is part of the TRIVAC System, TRIVAC BCS pumps may be operated with an inert gas ballast.

Since the IGS is intended for a reduced gas ballast for purging the pump, the water vapour tolerance of the pump is reduced depending on the settings to values in the 1 mbar range.

The inert gas supply needs to be opened before allowing the process gas to enter into the pump.

4.2.1 Non-Condensable Gases

If the process contains mainly permanent gases, the TRIVAC BCS may be operated without gas ballast (position 0), provided that the saturation vapour pressure at operating temperature is not exceeded during compression.

If the composition of the gases to be pumped is not known and if condensation in the pump cannot be ruled out, run the pump with the gas ballast valve open in accordance with Chapter 4.2.2.

4.2.2 Condensable Gases and Vapours

With the gas ballast valve open (position I) and at operating temperature, TRIVAC BCS pumps can pump pure water vapour up to the water vapour tolerance specified by the technical data. If the vapour pressure increases above the permissible level, the water vapour will condense in the oil of the pump.

When pumping vapours ensure that the gas ballast valve is open and that the pump has warmed up for approximately 30 minutes with the intake line closed.

Vapour phases may only be pumped up to the permissible limit after the pump has attained its operating temperature.

During pumping, vapours may dissolve in the oil. This changes the oil's properties and thus there is a risk of corrosion in the pump. Therefore, don't switch off the pump immediately after completion of the process. Instead, allow the TRIVAC BCS to continue operating with the gas ballast valve open and the intake line closed until the oil is free of condensed vapours.

We strongly recommend operating the pump in this mode for about 30 minutes after completion of the process.

Gas ballast valve

Caution

In cyclic operation, the TRIVAC BCS should not be switched off during the intervals between the individual working phases (power consumption is minimal when the pump is operating at ultimate pressure), but should continue to run with gas ballast valve open and intake port closed (if possible via a valve).

Once all vapours have been pumped off from a process (e.g. during drying), the gas ballast valve can be closed to improve the attainable ultimate pressure.

4.2.3 Operating Temperature

Proper operation of the TRIVAC BCS is ensured in the ambient temperature range between 12 °C (55 °F) to 40 °C (104 °F).

Warning



At operating temperature, the surface temperature of the oil case may lie between 40 °C (104 °F) and over 100 °C (212 °F), depending on the load.

There is the danger of receiving burns.

If – due to the ambient conditions – this temperature range is exceeded at either end of the range, then the operating range of the TRIVAC BCS can be adapted. The Leybold sales department will be pleased to answer any questions in this matter.

4.3 Switching Off / Shutdown

Since the TRIVAC BCS pump will commonly be exposed to aggressive and corrosive media, we recommend that you let the pump continue to operate even during long non-working intervals (e.g. overnight) with the intake line closed and the gas ballast valve open. This avoids corrosion during idle periods and difficulties when re-starting the pump under conditions where the lubricant has been chemically modified.

Caution

When pumping condensable media let the pump continue to operate with the gas ballast valve open and the intake line closed before switching off (see Chapter 4.2.2).

When using PFPE as the lubricant you must note the information given in Operating Instructions GA 07.009 when switching the pump off or shutting it down for a longer period of time.

If the TRIVAC BCS running with mineral oil is to be shutdown for an extended period after pumping aggressive or corrosive media or if the pump has to be stored, proceed as follows:

Warning



When pumping harmful substances, take adequate safety precautions.

Our technical sales department is available for further advice in these matters.

Drain the oil (see Chapter 5.4).

Add clean oil until the oil-level is at the “min” mark and let the pump operate for some time.

Then drain the oil and add clean oil until the oil level is at the “max.” mark.

Seal the connection ports. Special conservation or anti-corrosion oils aren't necessary.

Please also take note of the information given in Chapter 7 (Storing the Pump).

Shutdown through Monitoring Components

When the pump has been switched off due to overheating sensed by the motor coil protector, the pump must only be started manually after the pump has cooled down to the ambient temperature and after having removed the cause first.

Warning



Failure of the Control System or the Mains Power

In order to prevent the pump from running up unexpectedly after a mains power failure, the pump must be integrated in the control system in such a way that the pump can only be switched on again manually. This applies equally to emergency cut-out arrangements.

Warning



5 Maintenance

Warning



Disconnect the electrical connections before disassembling the pump. Make absolutely sure that the pump cannot be accidentally started.

If the pump has pumped harmful substances, ascertain the nature of hazard and take adequate safety measures.

Observe all safety regulations.

When using PFPE as the lubricant please observe all instructions given in Chapter 1.2 and in Operating Instructions GA 07.009.

When disposing of used oil, you must observe the applicable environmental regulations!

Due to the design concept, TRIVAC BCS pumps require very little maintenance when operated under normal conditions. The work required is described in the sections below.

Caution

All work must be carried out by suitably trained personnel. Maintenance or repairs carried out incorrectly will affect the life and performance of the pump and may cause problems when filing warranty claims.

Leybold offers practical courses on the maintenance, repair, and testing of TRIVAC BCS pumps. Further details are available from Leybold on request.

If the TRIVAC BCS is used in ambient air which is much contaminated, make sure that the air circulation and the gas ballast valve are not adversely affected.

When the TRIVAC BCS has been pumping corrosive media we recommend that possibly planned maintenance work be carried out immediately in order to prevent corrosion of the pump while it is at standstill.

For spare parts numbers please refer to the enclosed Spare Parts List.

In the case of custom models and special versions, please always state the number of the custom model or version together with its serial number.

5.1 Maintenance Plan (Recommendation)

| No. | Rotary vane pump TRIVAC D 16 BCS TRIVAC D 25 BCS | Measurement/test quantity Operating/auxiliary materials | Interval | | | | | | | Remarks |
|-----|---|--|----------|----|---|----|---|-----|--|--|
| | | | VE | VP | t | 6m | a | n-a | | |
| 1 | Operate the pump for at least 0.8 h with gas ballast. | | | | x | | | | | Condensed water is thus removed from the oil. |
| 2 | Check the oil level, if required change the oil.. | Oil: N 62 or special and alternative oils see Chapter 1.2 | x | x | | | | | | Refill: Only after the pump has been switched off. |
| 3 | Check the quality of the oil, change the oil if required. | visually (all oils) chemically (N 62 or HE 200) mechanically (N 62 or HE 200) | x | x | | x | | | | Visually: normally light and transparent, oil change is required when discolorations increase. Chemically: to DIN 51558, when the neutralisation number exceeds 2; then an oil change will be required. Mechanically: when viscosity is 20 % above the one of fresh oil; then an oil change will be required. |
| 4 | Clean the inlet screen in the intake port, change it as required. | Suitable cleaning agent and compressed air. | | | | x | | | | <ul style="list-style-type: none"> ■ Clean inlet screen with a cleaning agent and blow it out with compressed air under a suction hood. ■ Replace the defective inlet screen. Use a cleaning agent which complies with the national/international specifications. <p>Observe the safety regulations when using cleaning agents.</p> |
| 5 | Clean the internal demister, change it as required. | Suitable cleaning agent. | | | | | | x | | <p>Already clean before the maintenance interval has elapsed when the noise level increases.</p> <ul style="list-style-type: none"> ■ Clean internal demister with cleaning agent ■ Replace the defective internal demister ■ Dispose of the defective internal demister as special waste. <p>Cleaning agent according to national/international specifications.</p> <p>Observe the safety regulations when using cleaning agents.</p> |
| 6 | Check the edges of the teeth on the coupling element for any damages, change the coupling element as required. | | | | | | | x | | |
| 7 | Change the oil - and clean the oil level glass. | Oil: N 62 or special and alternative oils Suitable cleaning agent and compressed air. | | | | | | x | | <p>Oil change:</p> <ul style="list-style-type: none"> ■ First oil change after 100 operating hours. ■ Pump switched off and cold. <p>Exchange the oil while the pump is cold so as to avoid releasing adsorbed gases.</p> <p>Clean the oil level glass with a cleaning agent and blow it out with compressed air under a suction hood. Use cleaning agents only corresponding to the national/international specifications.</p> <p>Observe the safety regulations when using cleaning agents.</p> <p>Quantity of oil: see Technical data</p> |
| 8 | Check the fan of the pump and motor as well as the cooling fins on the motor for deposits, and clean as required. | Brush and industrial vacuum cleaner. | | | | | | x | | <p>Depending on the amount of dust check the pump and keep it clean.</p> <p>Caution: switch off the pump and ensure that it cannot run inadvertently (disconnect from the mains).</p> |

Key to maintenance plan

VE = Maintenance before switching on the system
 VP = Maintenance before starting production
 t = Daily maintenance
 6m = Six monthly maintenance
 a = Annual maintenance
 n-a = Maintenance every n years

We recommend that you service the pump every two years covering the following:

- Cleaning
- Checking the individual components
- Exchange of all seals
- Functional check

This check should be run by the Leybold Service.

5.2 Leybold Service

Contamination

Whenever you send in equipment to Leybold, indicate whether the equipment is contaminated or is free of substances which could pose a health hazard. If it is contaminated, specify exactly which substances are involved. You must use the form we have prepared for this purpose.

Form

A copy of the form has been reproduced at the end of these Operating Instructions: "Declaration of Contamination for Compressors, Vacuum Pumps and Components". Another suitable form is available from the Leybold homepage:

www.leybold.com under the headline "Support & Downloads".

Attach the form to the equipment or enclose it with the equipment. Do not place it together with the equipment inside the PE bag.

This statement detailing the type of contamination is required to satisfy legal requirements and for the protection of our employees.

Leybold must return to the sender any equipment which is not accompanied by a contamination statement.

5.3 Checking the Oil

During operation of the TRIVAC BCS the oil level must always remain between marks (9/2) and (9/3) at the oil-level glass. The amount of oil must be checked and topped up as required.

Caution

Fill in oil only after the pump has been switched off.

Pumps which have not directly been delivered from Leybold, e.g. in systems, may have been filled with oils different from N 62 or HE-200. In this case a refill with N 62 may cause problems. Therefore check before the refill the kind of oil in the pump and fill in only suitable oil or change the oil.

When operating the TRIVAC BCS in connection with the exhaust filter with lubricant return (ARS 16-25) the checking intervals are extended.

When using the oil float switch (LSS) remote monitoring of the lubricant is possible.

N 62 or HE 200 Oil

The ageing process for the standard operating fluid N 62 resp. HE 200 (see Chapter 1.2) will depend very much on the area of application for the pump.

a) Visual check

Normally the oil is clear and transparent. If the oil darkens, it should be changed.

b) Chemical check

The neutralisation number of N 62 oil is determined according to DIN 51558. If it exceeds 2, the oil should be changed.

c) Viscosity check

If the viscosity of N 62 at 25 °C exceeds a level of 240 mPas (20% higher than the viscosity of fresh oil) an oil change is recommended.

If gases or liquids dissolved in the oil result in a deterioration of the ultimate pressure, the oil can be degassed by allowing the pump to run for approx. 30 min. with the intake port closed and the gas ballast valve open.

When wanting to check the oil, switch off the pump first and drain out from the warm pump the required amount of oil through the oil drain (9/4) into a beaker or similar.

Hazardous substances may escape from the pump and the oil. Take adequate safety precautions. For example wear gloves, face protection or breathing protection.

Warning



PFPE

PFPE are practically inert against any kind of chemical and oxidative influence. Against Lewis acids (like boron trifluoride BF_3 , aluminium trichloride AlCl_3 , for example) they are not entirely inert. Here a reaction at temperatures of approximately 100 °C or more can be expected.

PFPE are thermally highly stable. A thermal decomposition can occur only at temperatures over 290 °C.

Perfluorinated polyethers will, when suffering thermal decomposition, release toxic and corrosive gases.

Warning



In the case of PFPE at least a visual check is recommended.

Normally the oil will be light and transparent. In the case of an increasing discoloration it is likely that the oil has taken up either liquid or solid process media, and an oil change is recommended.

5.4 Oil Change

Warning



Before pumping oxygen (or other highly reactive gases) at concentrations exceeding the concentration in the atmosphere (> 21 % for oxygen) it will be necessary to use a special pump. Such a pump will have to be modified and de-greased, and an inert special lubricant (like PFPE) must be used.

Hazardous substances may escape from the pump and the oil. Take adequate safety precautions. For example wear gloves, face protection or breathing protection.

Observe all safety regulations.

Mineral oil (N 62 or HE 200)

For proper operation of the pump, it is essential that the pump has an adequate supply of the correct and clean oil at all times.

The oil must be changed when it looks dirty or if it appears chemically or mechanically worn out.

The oil should be changed after the first 100 operating hours and then at least every 2,000 to 3,000 operating hours or after one year. At high intake pressures and intake temperatures and/or when pumping contaminated gases, the oil will have to be changed more frequently.

Further oil changes should be made before and after long-term storage of the pump.

If the oil becomes contaminated too quickly, install a dust filter and/or oil filter. Contact us for more information in this matter.

PFPE

PFPE lubricants are chemically almost inert. Thus they do not suffer ageing like mineral oils, for example.

However, PFPE lubricants offer a reduced dispersing behaviour compared to that of mineral oils. For this reason, any contaminant particles entering into the pump may deposit themselves within the pump and cause damage. The ingress of process media can also cause impairments within the pump, for example through condensation and a reduction in the attainable ultimate pressure or by attacking components through aggressive media. In this case pumps with a filling of PFPE must always be operated in connection with a suitable oil filter facility.

When the oil filter facilities are changed early enough, it will only be required to exchange the PFPE rarely. In such cases we recommend to exchange the PFPE once a year to be on the safe side.

Shorter oil change intervals will be necessary in the case of

- inadequate oil filter facilities
- oil filter changes which are done too late
- when pumping contaminated gases
- when pumping extremely reactive substances.

How often a PFPE exchange will be necessary can only be decided on a case-by-case basis depending on the level and type of contamination.

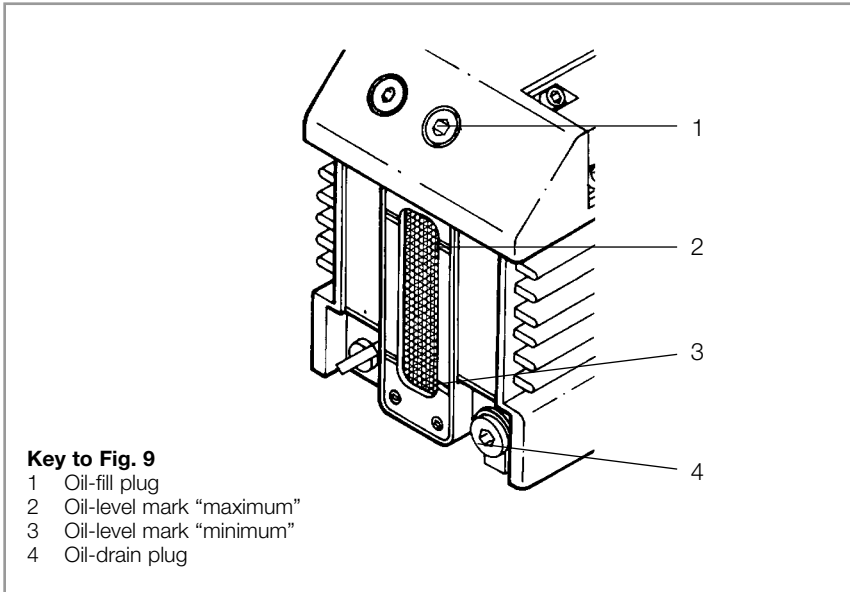

Fig. 9 Oil change

Required tool for the oil change:

Allen key size 8.

Normally change the oil after the pump has been switched off and while the pump is still warm. Change the oil while the pump is cold if dangerous gases may be released.

If there is the danger that the operating agent may present a hazard in any way due to decomposition of the oil, or because of the media which have been pumped, you must determine the kind of hazard and ensure that all necessary safety precautions are taken.

Warning



Remove the oil-drain plug (9/4) and let the used oil drain into a suitable container. When the flow of oil slows down, screw the oil-drain plug back in, briefly switch on the pump (max. 10 s) and then switch it off again. Remove the oil-drain plug once more and drain out the remaining oil.

Screw the oil-drain plug back in (check the gasket and reinstall a new one if necessary).

Remove the oil-fill plug (9/1) and fill in fresh oil.

Screw the oil-fill plug (9/1) back in.

When an exhaust filter with lubricant return has been installed on the pump please also exchange the oil there.

We can only guarantee that the pump operates as specified by the technical data if the lubricants recommended by us are used.

Caution

5.5 Cleaning the Dirt Trap

A wire-mesh sieve is located in the intake port of the pump to act as a dirt trap for foreign objects. It should be kept clean to avoid a reduction of the pumping speed.

For this purpose, remove the dirt trap (2/2) from the intake port and rinse it in a suitable vessel with solvent. Then thoroughly dry it with compressed air.

If the dirt trap is defective, replace it with a new one.

Caution

The cleaning intervals depend on the application. If the pump is exposed to large amounts of abrasive materials, a dust filter should be fitted into the intake line.

5.6 Removing and Fitting the Internal Demister

(not required for PFPE)

Required tools: Allen keys size 5 and 8

Required spare parts:

Gasket for oil case 200 10 737

Internal demister:

D 16 BCS 390 26 012

D 25 BCS 390 26 013

The internal demister is spring-mounted in a frame. When it is clogged, it rises periodically to reduce the pressure difference created. The resultant noise at high intake pressures indicates that the internal demister is dirty.

Periodically clean or replace the internal demister; the maintenance interval depends on the application. Use a suitable solvent for cleaning.

Shutdown the pump and drain the oil (see Chapter 5.4).

Remove the **four recessed** screws (10/5) on the oil case (10/1). Don't remove the **non-recessed screws**; they hold the motor flange in place and need not be removed.

Pull the oil case forward off the pump.

Remove the gasket (10/7).

Press the spring buckles (10/2) sideways away from the frame (10/4).

Lift off the frame and remove the internal demister (10/3).

Clean all parts and check that they are in perfect condition; if not, replace them with new parts.

Reassemble in the reverse order.

Torque for the screws (10/5) is 5 Nm.

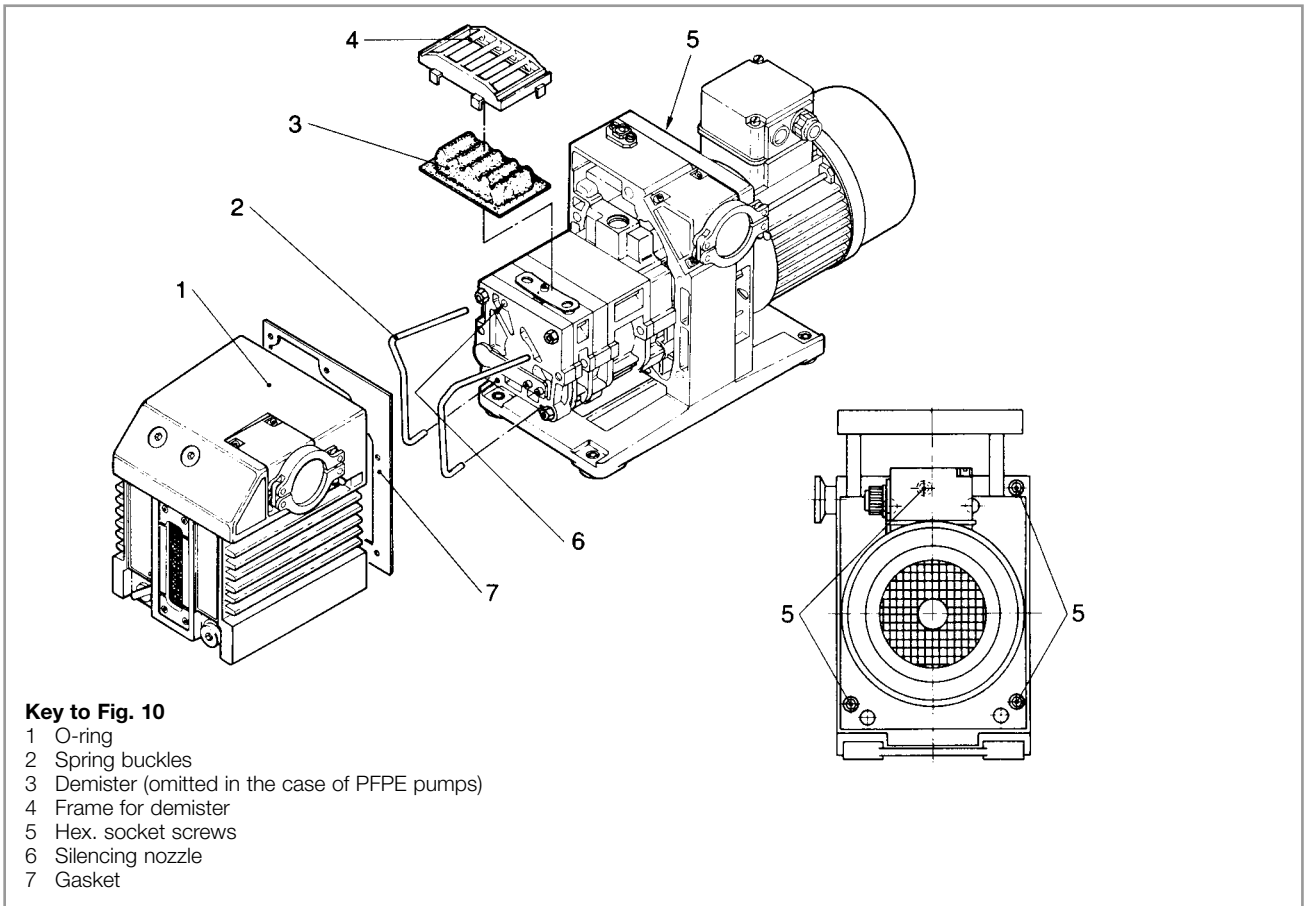

Fig. 10 Removal and fitting of the internal demister

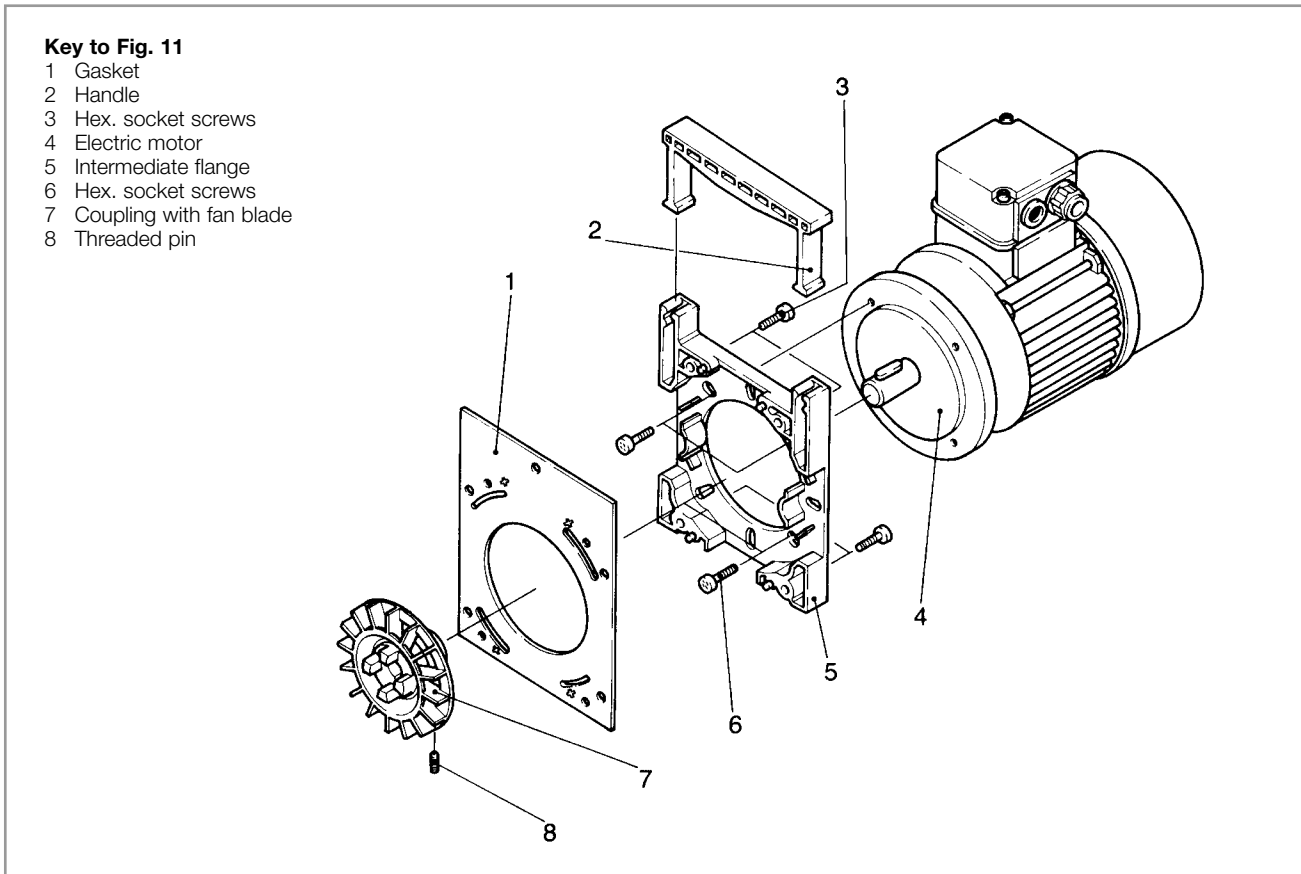

Fig. 11 Disassembly and reassembly of the electric motor

5.7 Disassembly and Reassembly of the Electric Motor

Warning



Before starting work, always disconnect the motor from the mains. Reliably prevent the pump from running up.

Required tools:

Screwdriver 1.0 x 5.5 mm (for junction box), open-jaw wrenches 7 mm and 19 mm (for junction box), Allan keys 3 mm, 5 mm, 6 mm, possibly a pulser for the coupling.

Disconnect the pump from the mains.

Support the motor.

Unscrew the four **non-recessed** hex. socket screws (11/3).

Remove the intermediate flange (11/5) together with the electric motor.

Remove the gasket (11/1).

Remove the handle (11/2).

Loosen the threaded pin and pull the coupling (11/7) with the fan blade off the motor shaft.

Unscrew the hex. socket screws (11/6).

Remove the electric motor (117/4).

Clean all parts and check that they are in perfect condition; if not, replace them with new parts.

Reassemble in the reverse order.

5.8 Replacing the Outer Shaft Seal

Oil stains under the housing of the coupling indicate a worn shaft sealing ring.

The shaft sealing ring may be exchanged without having to remove or disassemble the pump module.

Required tools: Allen keys size 3, 5 and 8, flat-nose pliers, plastic hammer, shaft seal driver, possibly a puller for the coupling.

Required spare parts:

| | |
|-----------------|------------|
| Shaft seal (2x) | 200 09 235 |
| Bushing | 231 92 026 |

Shutdown the pump.

Drain the oil (see Chapter 5.4).

Support the motor.

Unscrew the four **non-recessed** hex. socket screws (11/3) and remove the motor (11/4) with the intermediate flange.

Remove gasket (11/1).

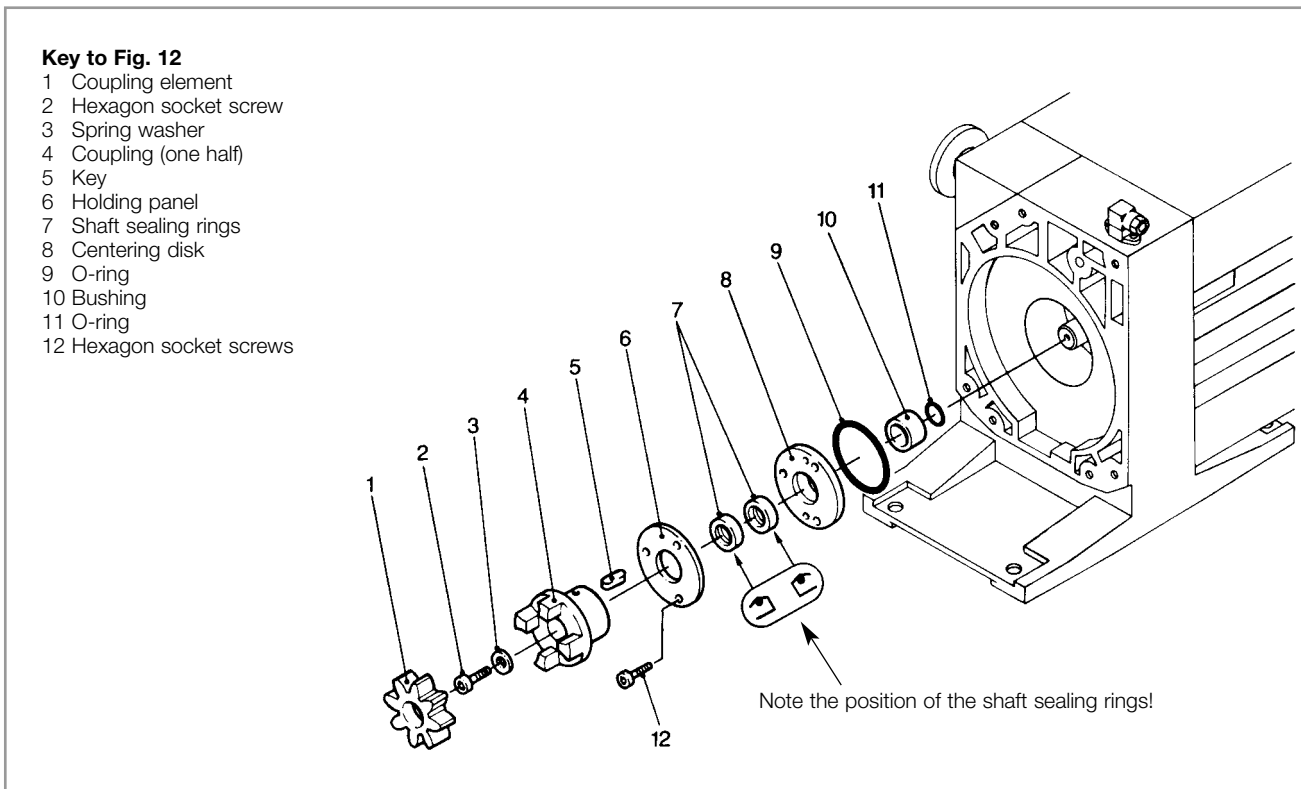

Fig. 12 Exchanging the shaft seals

Remove coupling element (12/1).

Unscrew screw (12/2) and pull off the spring washer (12/3).

Pull off the coupling half (12/4).

Remove key (12/5).

Unscrew the hex. socket screws (12/12) and remove the holding panel (12/6).

Pull the centering disk (12/8) out.

If the centering disc does not come loose, use the forcing thread into which screws (12/12) can be screwed in.

Pull the bushing (12/10) out and take the O-ring (12/11) off from the shaft.

Force the shaft seals (12/7) out of the centering disk.

Remove the O-ring (12/9).

We recommend the use of a new shaft seal and bushing for reassembly.

Before fitting the new shaft seal, moisten it slightly with a little vacuum pump oil.

Using a suitable plastic or aluminium cylinder (shaft seal driver) and a plastic hammer, force the shaft seals (12/7) carefully and without bending them into the centering disk (for position of shaft seal, see Fig. 12).

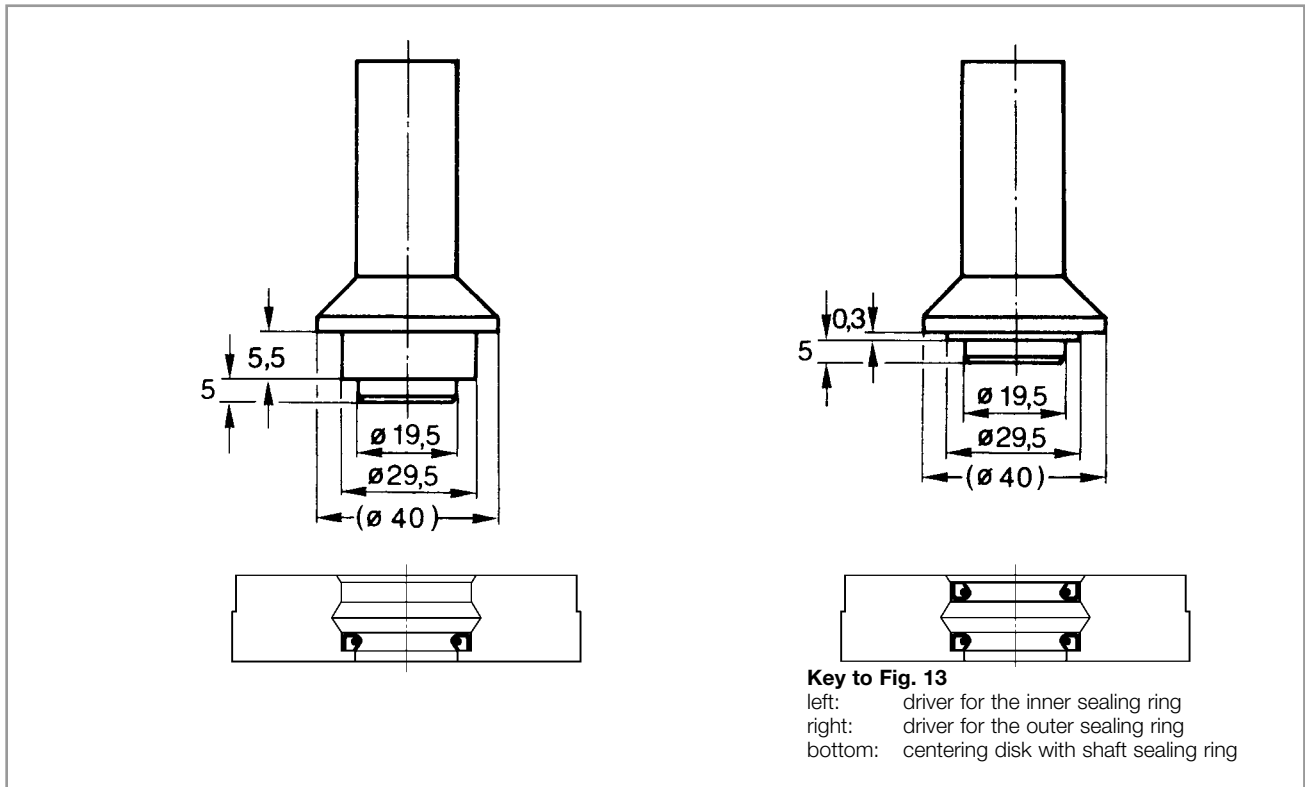

Fig. 13 Shaft sealing ring driver

If you do not have a shaft seal driver, place the shaft seal on the centering disk and carefully force it in with light blows of the plastic hammer.

The shaft seal must not be bent.

Insert the O-ring (12/9) and (12/11) into their grooves.

Carefully push the centering disk (12/8) with the shaft seal onto the shaft and up against the end plate.

Push the holding panel (12/6) on and tighten with bolts (12/12).

Insert the bushing (12/10) carefully at the center of the centering disk.

Insert the key (12/5).

Mount the pump-half of the coupling (12/4) on the shaft.

Install the spring washer (12/3) and tighten the screw (12/2).

Insert the coupling element (12/1) into the coupling and mount the motor (see Chapter 5.7).

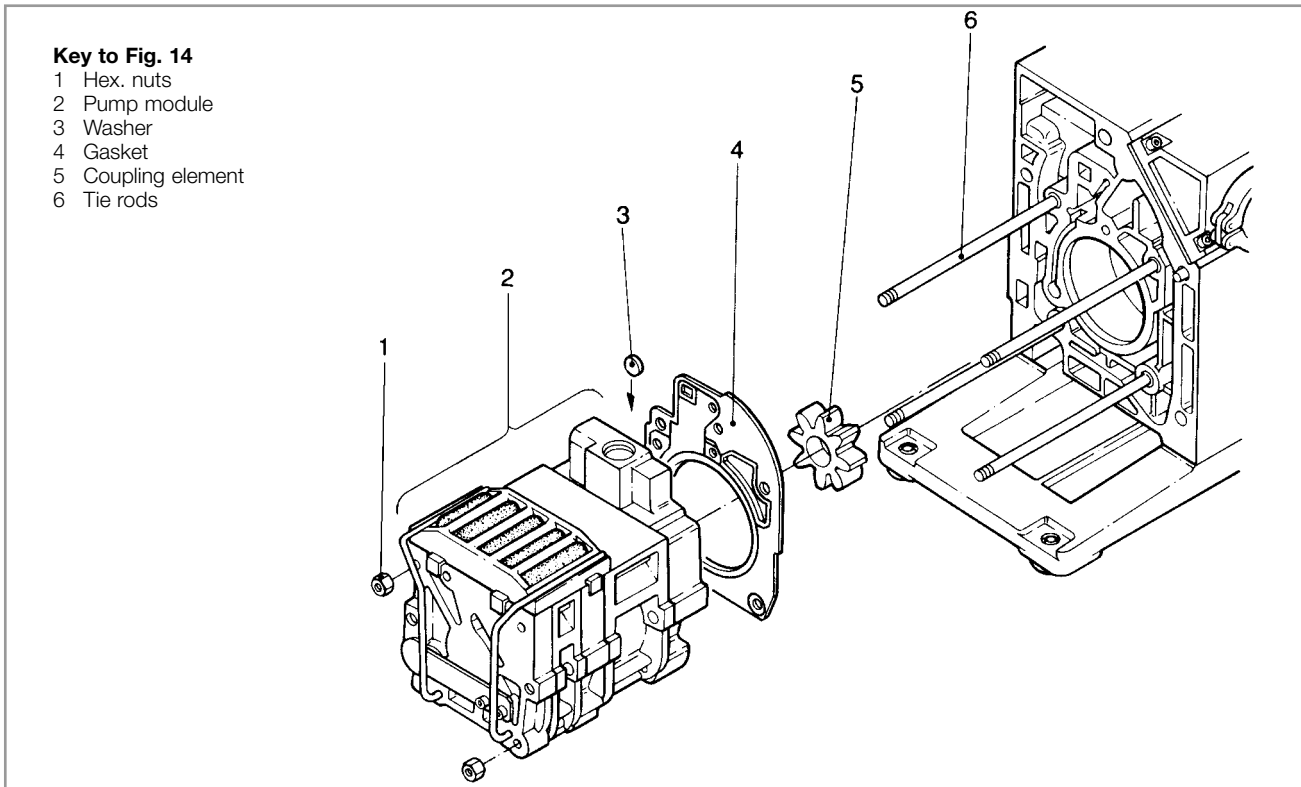

Fig. 14 Removing and remounting the pump module

5.9 Removing and Remounting the Pump Module

Required tools: Allen keys size 3, 4, 6 and 8 mm, box wrench size 10, possibly pliers, torque wrench.

Required spare parts:

Gaskets:

200 10 736

200 10 737

Removing the Pump Module

Drain the oil and remove the oil case (see Chapter 5.6).

Unscrew the hex. nuts (14/1).

Pull the entire pump module (14/2) forward off the tie rods (14/6).

Caution

When doing so, ensure that the individual pin-fitted parts are not loosened. Further disassembly of the pump module should only be carried out by a trained service engineer.

Remove the gasket (14/4).

Remove the coupling element (14/5).

After removing the protective shipping materials, handle the new pump module with care.

Caution

Before installing a new pump module, remove the four tie rods from the new module and insert them in the old one for protection during shipment.

Remounting the Pump Module

When installing a new pump module, it is also advisable to use a new gasket (14/4).

Check the coupling element (14/5) for damage; if necessary, install a new one.

Use the tie rods supplied with the new pump module only if the old ones are damaged. To do so, unscrew the old tie rods with lock nuts, and screw in the new ones. With the aid of the lock nuts, tighten the tie rods. Then remove the lock nuts.

Before installing the pump module, please check whether the washer (14/3) is correctly seated in its opening.

Push the gasket (14/4) onto the tie rods (14/6), push the coupling element (14/5) onto one coupling half.

Push the entire pump module (new or repaired) onto the tie rods.

Screw on the hex. nuts (14/1) and carefully cross-tighten them (torque 7.5 Nm).

Mount the oil case together with the gasket (see Chapter 5.6).

Fill in oil.

6 Troubleshooting

| Fault | Possible cause | Remedy | Repair |
|---|--|--|---|
| Pump does not start. | Wiring is malfunctioning. Motor protection switch incorrectly set. Operating voltage does not match motor. Motor is malfunctioning. Oil temperature is below 12 °C. Oil is too thick. Exhaust filter/exhaust line is clogged. Pump is seized up (sign: pump is jammed). | Check and repair wiring. Set motor protection switch properly. Replace the motor. Replace the motor. Heat the pump and pump oil or use a different oil. Change the oil. Replace the filter or clean the exhaust line. Repair the pump. | - 3.4 5.7 5.7 4.2.3/5.4 5.4 - Service |
| Pump does not reach ultimate pressure. | Measuring technique or gauge is unsuitable. External leak ¹⁾ . Anti-suckback valve is malfunctioning. Exhaust valve is malfunctioning. Oil is unsuitable. Vacuum lines are dirty. Pump is too small. | Use correct measuring technique and gauge. Measure the pressure directly at the pump's intake port. Repair the pump. Repair the valve. Repair the valve. Change the oil (degas it, if necessary). Clean the vacuum lines. Check the process data, replace the pump, if necessary. | - Service Service Service 5.4 - - |
| Pumping speed is too low. | Inlet screen in the intake port is clogged. Exhaust filter is clogged. Connecting lines are too narrow or too long. | Clean the inlet screen. Precaution: install a dust filter in the intake line. Install new filter element. Use adequately wide and short connecting lines. | 5.5 - 3.3 |
| After switching off the pump under vacuum, pressure in the system rises too fast. | System has a leak. Anti-suckback valve is malfunctioning. | Check the system. Repair the valve. | - Service |
| Pump gets hotter than usually observed. | Cooling air supply is obstructed. Ambient temperature is too high. Process gas is too hot. Oil level is too low. Oil is unsuitable. Oil cycle is obstructed. Exhaust filter/exhaust line is obstructed. Exhaust valve is malfunctioning. Pump module is worn out. | Set pump up correctly. Set pump up correctly. Change the process. Add oil. Change the oil. Clean or repair the oil lines and channels. Replace the exhaust filter, clean the exhaust line. Repair the valve. Replace the pump module. | 3.1 3.1/4.2.3 - 5.3 5.4 Service - Service 5.9 |
| Oil in the intake line or in the vacuum vessel. | Oil comes from the vacuum system. Anti-suckback valve is blocked. Sealing surfaces of the anti-suckback valve are damaged or dirty. Oil level is too high. | Check the vacuum system. Clean or repair the anti-suckback valve. Clean or repair intake and anti-suckback valve Drain out excess oil. | - Service Service 5.3 |
| Oil is turbid. | Condensation. | Degas the oil or change the oil and clean the pump. Precaution: open the gas ballast valve or fit separator. | 4.2.2/5.4 |
| Pump is excessively noisy. | Oil level is much too low (oil level is no longer visible). Silencing nozzle is clogged. Intake pressure is too high. Internal demister is clogged. Coupling element is worn. Vaness or bearings are damaged. | Add oil. Clean the silencing nozzle or replace it. Lower the intake pressure. Clean or replace demister. Install new coupling element. Repair pump. | 5.3/5.4 Fig. 10 - 5.6 5.7 Service |

* Repair information: Refer to the stated section in these Operating Instructions.

1) Bubble test: The warm pump with degassed oil is running without gas ballast and the intake is blanked off. The exhaust line is led into a vessel with water. If an evenly spaced line of bubbles appears then the pump has an external leak.

7 Shelving after Use

Before the pump is shelved it must be properly disconnected from the vacuum system, purged with dry nitrogen and the oil should be changed too.

The inlets and outlets of the pump must be sealed with the shipping seals which are provided upon delivery.

The gas ballast switch must be set to the "0" position and if the pump is to be shelved for a longer period of time it should be sealed in a PE bag containing some desiccant (silica gel).

Before putting a pump into operation once more it should be stored in a dry place preferably at room temperature (20 °C = 68 °F).

When a pump is put into operation after it has been shelved for over one year, standard maintenance should be run on the pump and the oil should also be exchanged. We recommend that you contact the Leybold service.

8 Waste Disposal

Contamination

The equipment may have been contaminated by the process or by environmental influences. In this case the equipment must be decontaminated in accordance with the relevant regulations. Leybold offers this service at fixed prices. Further details are available on request.

Warning



Contaminated parts can be detrimental to health and environment. Before beginning with any work, first find out whether any parts are contaminated. Adhere to the relevant regulations and take the necessary precautions when handling contaminated parts.

Separate clean components according to their materials, and dispose of these accordingly. Leybold offers this service. Further details are available on request.

When sending any equipment to Leybold, observe the regulations given in Section "5.2 Leybold Service".

Disposal of Waste Oil

Owners of waste oil are entirely self-responsible for proper disposal of this waste.

Waste oil from vacuum pumps must not be mixed with other substances or materials.

Waste oil from vacuum pumps (Leybold oils which are based on mineral oils) which are subject to normal wear and which are contaminated due to the influence of oxygen in the air, high temperatures or mechanical wear must be disposed of through the locally available waste oil disposal system.

Waste oil from vacuum pumps which is contaminated with other substances must be marked and stored in such a way that the type of contamination is apparent. This waste must be disposed of as special waste.

European, national and regional regulations concerning waste disposal need to be observed. Waste must only be transported and disposed of by an approved waste disposal vendor.

PFPE

PFPE from vacuum pumps may be regenerated, if required, and provided the quantities are large enough. For this, please contact us for assistance.

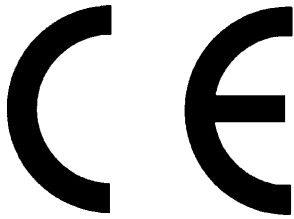

EC Declaration of Conformity

We – Leybold Vacuum GmbH – herewith declare that the products defined below meet the requirements of the relevant EC directives by design, type and versions which are brought into circulation by us.

In case of any product changes made without our approval, this declaration will be void.

Designation of the products: Rotary vane pump
Types: **TRIVAC BCS D 16 BCS, D 25 BCS**
Part Nos. 113 68/69
113 78/79
154 50/51

The products conform to the following directives:

- EC Directive on Machinery (98/37/EG) and (98/79/EG)
- EC Directive on Low-Voltages (73/23/EWG) and (93/68/EG)
- EC EMC Directive (89/336/EWG, 91/263/EWG, 92/31/EWG) and (93/68/EWG)

Applied harmonised standards:

- EN 1012 - 2 1996
- EN 60204 - 1 1997
- EN 60034 - 1 2004

Cologne, April 4, 2006

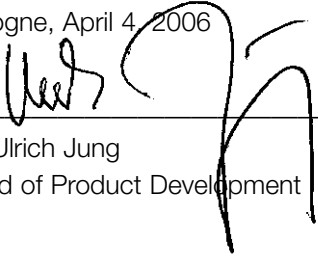

Dr. Ulrich Jung
Head of Product Development

Cologne, April 3, 2006



Mr. Wolfgang Giebmanns
Development Design



Leybold Vacuum GmbH
Bonner Strasse 498
D-50968 Cologne
Phone: ++49 (0)221 347-0
Fax: ++49 (0)221 347-1250
documentation@leybold.com

www.leybold.com

EC Manufacturer's Declaration

in the spirit of Appendix IIb to the 98/37/EG Machinery Guidelines

We – Leybold Vacuum GmbH – herewith declare that the products defined below meet the requirements of the relevant EC directives by design, type and versions which are brought into circulation by us.

In case of any product changes made without our approval, this declaration will be void.

Designation of the products: Rotary vane pump

Types: **TRIVAC BCS D 16 BCS without motor, D 25 BCS without motor**

Part Nos. 113 70, 113 72, 113 80, 113 82

The products conform to the following directives:

- EC Directive on Machinery (98/37/EG) and (98/79/EG)

Applied harmonised standards:

- EN 1012 - 2, 1996
Compressors and vacuum pumps, safety requirements - Part 2: Vacuum pumps

Cologne, March 15, 2006



Dr. Ulrich Jung
Head of Product Development

Cologne, March 15, 2006



Mr. Wolfgang Giebmanns
Development Design

**Leybold**
vacuum

Leybold Vacuum GmbH
Bonner Strasse 498
D-50968 Cologne
Phone: ++49 (0)221 347-0
Fax: ++49 (0)221 347-1250
documentation@leybold.com

www.leybold.com

Sales and Service Net Worldwide

Germany

Leybold Vacuum GmbH
Bonner Strasse 498
D-50968 Cologne
Phone: +49-221-347 1234
Fax: +49-221-347 1245
sales@leybold.com

Leybold Vacuum GmbH
Sales Area North/East
Branch office Berlin
Buschkrugallee 33
1. Obergeschoss
D-12359 Berlin
Phone: +49-30-435 609 0
Fax: +49-30-435 609 10
sales.berlin@leybold.com

Leybold Vacuum GmbH
Sales Area South/Southwest
Branch office Munich
Karl-Hammerschmidt-Strasse 38
D-85609 Aschheim/Dornach
Phone: +49-89-357 33 90
Fax: +49-89-357 33 933
sales.muenchen@leybold.com
service.muenchen@leybold.com

Leybold Vacuum GmbH
Sales Area West
Branch office Cologne
Emil-Hoffmann-Straße 43
D-50996 Cologne-Suerth
Phone: +49-221-347 1270
Fax: +49-221-347 1291
sales.koeln@leybold.com

Leybold Vacuum GmbH
Service Center
Emil-Hoffmann-Straße 43
D-50996 Cologne-Suerth
Phone: +49-221-347 1439
Fax: +49-221-347 1945
service@leybold.com

Leybold Vacuum GmbH
Mobile after sales service
Emil-Hoffmann-Straße 43
D-50996 Cologne-Suerth
Phone: +49-221-347 1765
Fax: +49-221-347 1944
kundendienst@leybold.com

Leybold Vacuum
Dresden GmbH
Zur Wetterwarte 50, Haus 304
D-01109 Dresden
Service:
Phone: +49-351-88 55 00
Fax: +49-351-88 55 041
info@leybold-dresden.de
www.leybold-dresden.de

Europe

Belgium
Leybold Vacuum Nederland B.V.
Belgisch bijkantoor
Leuvensesteenweg 542-9A
B-1930 Zaventem
Sales:
Phone: +32-2-711 00 83
Fax: +32-2-720 83 38
sales.belgium@leybold.com
Service:
Phone: +32-2-711 00 82
Fax: +32-2-720 83 38
service.belgium@leybold.com

France
Leybold Vacuum France S.A.
7, Avenue du Québec
Z.A. de Courtaboef, B.P. 42
F-91942 Courtaboef Cedex
Sales and Service:
Phone: +33-1-69 82 48 00
Fax: +33-1-69 07 57 38
sales.orsay@leybold.com

Leybold Vacuum France S.A.
Valence Factory
640, Rue A. Bergès - B.P. 107
F-26501 Bourg-lès-Valence Cedex
Phone: +33-4-75 82 33 00
Fax: +33-4-75 82 92 69
marketing.valence@leybold.com

Great Britain
Leybold Vacuum UK Ltd.
Unit 2
Silverglade Business Park
Leatherhead Road
GB-Chessington Surrey KT9 2QL
Sales:
Phone: +44-13-7273 7310
Fax: +44-13-7273 7001
sales.uk@leybold.com
Service:
Phone: +44-13-7273 7320
Fax: +44-13-7273 7003
service.uk@leybold.com

Italy
Leybold Vacuum Italia S.p.A.
8, Via Trasimeno
I-20128 Milano
Sales:
Phone: +39-02-27 22 31
Fax: +39-02-27 20 96 41
sales@leybold.it
Service:
Phone: +39-02-27 22 31
Fax: +39-02-27 20 96 41
service@leybold.it

Field Service Base
Z.I. Le Capanne
I-05021 Acquasparta (TR)
Phone: +39-0744-93 03 93
Fax: +39-0744-94 42 87
service@leybold.it

Netherlands
Leybold Vacuum Nederland B.V.
Computerweg 7
NL-3542 DP Utrecht
Sales and Service:
Phone: +31-346-58 39 99
Fax: +31-346-58 39 90
sales.netherlands@leybold.com
service.netherlands@leybold.com

Spain
Leybold Vacuum Spain, S.A.
C/ Huelva, 7
E-08940 Cornellà de Llobregat
(Barcelona)
Sales:
Phone: +34-93-666 46 16
Fax: +34-93-666 43 70
sales.spain@leybold.com
Service:
Phone: +34-93-666 49 51
Fax: +34-93-685 40 10

Sweden
Leybold Vacuum Scandinavia AB
Box 9084
SE-40092 Göteborg
Sales and Service:
Phone: +46-31-68 84 70
Fax: +46-31-68 39 39
info@leybold.se
Visiting/delivery address:
Datavägen 57B
SE-43632 Askim

Switzerland
Leybold Vacuum Schweiz AG
Leutschenbachstrasse 55
CH-8050 Zürich
Sales:
Phone: +41-44-308 40 50
Fax: +41-44-302 43 73
sales@leybold.ch
Service:
Phone: +41-44-308 40 62
Fax: +41-44-308 40 60

America

USA
Leybold Vacuum USA Inc.
5700 Mellon Road
Export, PA 15632
info@leyboldvacuum.com
Sales:
Eastern & Central time zones
Phone: +1-724-327-5700
Fax: +1-724-325-3577
Pacific, Mountain,
Alaskan & Hawaiian time zones
Phone: +1-480-752-9191
Fax: +1-480-752-9494
Service:
Phone: +1-724-327-5700
Fax: +1-724-325-3577

Asia

P.R. China
Leybold Vacuum (Tianjin)
International Trade Co., Ltd.
Beichen Economic
Development Area (BEDA),
No. 8 Western Shuangchen Road
Tianjin 300400, China
Sales and Service:
Phone: +86-22-2697 0808
Fax: +86-22-2697 4061
leybold@leybold.com.cn

Leybold Vacuum (Tianjin)
Equipment Manufacturing Co., Ltd.
Beichen Economic
Development Area (BEDA),
No. 8 Western Shuangchen Road
Tianjin 300400, China
Phone: +86-22-2697 0808
Fax: +86-22-2697 4061
Fax: +86-22-2697 2017
leybold@leybold.com.cn

Leybold Vacuum (Tianjin)
International Trade Co., Ltd.
Beijing Branch:
1-908, Beijing Landmark Towers
8 North Dongsanhuan Road
Chaoyang District
Beijing 100004, China
Sales and Service:
Phone: +86-10-6590-7607
Fax: +86-10-6590-7622

Leybold Vacuum (Tianjin)
International Trade Co., Ltd.
Shanghai Branch:
Add: No. 33, 76 Futedong San
Rd., Waigaoqiao FTZ,
Shanghai 200131, China
Sales and Service:
Phone: +86-21-5064-4666
Fax: +86-21-5064-4668
leybold_sh@leybold.com.cn

Leybold Vacuum (Tianjin)
Guangzhou Branch:
Add: G/F, #301 Building,
110 Dongguangzhuang Rd.
Tianhe District,
Guangzhou 510610, China
Sales:
Phone: +86-20-8723-7873
Phone: +86-20-8723-7597
Fax: +86-20-8723-7875
leybold_gz@leybold.com.cn

India
Leybold Vacuum India Pvt Ltd.
A-215 Road No. 30
MIDC Wagle Industrial Estate
Thane(W) - 400 604 Maharashtra
India
Sales and Service:
Phone: +91-22-2581 2929
Fax: +91-22-2581 2626
ivt2004@yahoo.com

Japan
Leybold Vacuum
Japan Co., Ltd.
Head Office
Tobu A.K. Bldg. 4th Floor
23-3, Shin-Yokohama
3-chome
Kohoku-ku, Yokohama-shi
Kanagawa-ken 222-0033
Sales:
Phone: +81-45-4713330
Fax: +81-45-4713323

Leybold Vacuum
Japan Co., Ltd.
Osaka Branch Office
MURATA Bldg. 7F
2-7-53, Nihi-Miyahara
Yodogawa-ku
Osaka-shi 532-0004
Sales:
Phone: +81-6-6393-5211
Fax: +81-6-6393-5215

Leybold Vacuum
Japan Co., Ltd.
Tsukuba Technical S.C.
Tsukuba Minami Daiichi
Kogyo Danchi
21, Kasumi-no-Sato,
Ami-machi, Inashiki-gun
Ibaraki-ken, 300-0315
Service:
Phone: +81-298-89-2841
Fax: +81-298-89-2838

Korea
Leybold Vacuum Korea Ltd.
#761-4, Yulkeum-ri,
SungHwan-eup, Cheonan-City
Choongchung-Namdo,
330-807, Korea
Sales:
Phone: +82-41-580-4420
Fax: +82-41-588-3737
Service:
Phone: +82-41-580-4415
Fax: +82-41-588-3737

Singapore
Leybold Vacuum
Singapore Pte Ltd.
No.1, International
Business Park,
B1-20B, The Synergy
Singapore 609917
Sales and Service:
Phone: +65-66652910
Fax: +65-65668202
vacuum@leyboldvac.com.sg

Taiwan
Leybold Vacuum Taiwan Ltd.
No 416-1, Sec. 3
Chung-Hsin Rd., Chu-Tung
Hsin-Chu, Taiwan, R.O.C.
Sales and Service:
Phone: +886-3-5833988
Fax: +886-3-5833999

Hotline
Sales: +49-221-347 1234
Service: +49-221-347 1765
sales@leybold.com
service@leybold.com

Leybold Vacuum Products Inc.
5700 Mellon Road
Export, PA. 15632-8900
Phone: 724-327-5700
Fax: 724-325-3577
info@leyboldvacuum.com

Leybold Vacuum GmbH
Bonner Strasse 498
D-50968 Cologne
Phone: +49-221 347-0
Fax: +49-221 347-1250
info@leybold.com

Leybold
vacuum

www.leybold.com